

INSTALLATION INSTRUCTIONS

MODELS (-)XRD-01RMDCM3 & (-)XRD-01RMDDM3

VERTICAL AIRFLOW ECONOMIZERS

▲WARNING

THIS ACCESSORY IS TO BE INSTALLED BY A QUALIFIED, LICENSED SERVICE PERSON. TO AVOID UNSATISFACTORY OPERATION OR DAMAGE TO THE PRODUCT AND POSSIBLE UNSAFE CONDITIONS, INCLUDING ELECTRICAL SHOCK, REFRIGERANT LEAKAGE AND FIRE, THE INSTALLATION INSTRUCTIONS PROVIDED WITH THIS ACCESSORY MUST BE STRICTLY FOLLOWED AND THE PARTS SUPPLIED USED WITHOUT SUBSTITUTION. DAMAGE TO THE PRODUCT RESULTING FROM NOT FOLLOWING THE INSTRUCTIONS OR USING UNAUTHORIZED PARTS MAY BE EXCLUDED FROM THE MANUFACTURER'S WARRANTY COVERAGE.

▲WARNING

DISCONNECT ELECTRICAL POWER TO THE UNIT. FAILURE TO DO SO CAN CAUSE ELECTRICAL SHOCK RESULTING IN PERSONAL INJURY OR DEATH.

▲WARNING

THE SMOKE DETECTOR MUST NOT BE RELIED UPON AS THE PRIMARY SMOKE DETECTION IN BUILDING SAFETY. THE ECONOMIZER SMOKE DETECTOR DE-ENERGIZES THE SUPPLY FAN AND CLOSES THE OUTSIDE AIR DAMPER WHEN SMOKE IS DETECTED. REFER TO ENCLOSED SMOKE DETECTOR INSTRUCTIONS (SECTION 7) FOR TESTING OF ADEQUATE SMOKE SENSOR AIRFLOW UPON INSTALLATION OF (-)XRD-01RMDDM3 ECONOMIZER WITH SMOKE DETECTOR CAPABILITIES. SUFFICIENT DUCTED AIR VELOCITY MUST BE PRESENT ACROSS THE SMOKE DETECTOR SAMPLING TUBE TO ENSURE PROPER OPERATION. ADDING POWERED EXHAUST MAY BE REQUIRED IN BUILDINGS WITH EXCESSIVE ENVELOPE AIR LOSSES AND/OR RESTRICTIVE RETURN AIR CONDITIONS TO THE UNIT PREVENTING ADEQUATE RETURN AIR TO THE UNIT WHEN ECONOMIZER IS OPEN TO OUTSIDE AIR.

TOOLS REQUIRED FOR INSTALLATION:

$\frac{3}{8}$ " electric drill with $\frac{5}{16}$ " socket

Small flat blade (0.125" wide) screwdriver

TABLE 1

PACKAGE CONTENTS economizer w/ controller, actuator, & outside air enthalpy sensor attached		(-)XRD-01RMDCM3	(-)XRD-01RMDDM3 w/ smoke detector
ITEM	DESCRIPTION	PART No.	PART No.
1			
2	(3) Permanent Filters (23.875" X 23.875")	420000176	420000176
3	Spotweld Assy - Bird Screen	6036016 / BSWA	6036016S / BSWA
4	Exhaust Air Rainhood Assy – Birdscreen Front Support	**36016 / EHB2	**36016S / EHB2
5	OA Rainhood Assy - Left Side	**36016 / EHSL	**36016S / EHSL
6	OA Rainhood Assy - Right Side	**36016 / EHSR	**36016S / EHSR
7	Exhaust Air Rainhood - Left Side	**36016 / EHS2L	**36016S / EHS2L
8	Exhaust Air Rainhood – Right Side	**36016 / EHS2R	**36016S / EHS2R
9	OA Filter Rail Assy	**36016 / EHT2	**36016S / EHT2
10	OA Rainhood Assy – Top	**36016 / EHT	**36016S / EHT
11	OA Rainhood - Front Filter Support	**36016 / EHB	**36016S / EHB
12	Adaptor Panel	6036016 / ADP	6036016S / ADP
13	Hardware Bag	6036D16 / HDW	6036D16S / HDW
14	Smoke Detector w/ Harness	-----	610431412
15	Sampling Tube	-----	610431423
16	Sampling Tube Bracket	-----	6036016S / BRKT

** = Paint Color. 59 = Warm Dark Grey, 60 = Green, 61 = R-410A Beige, 62 = Light Grey

FIGURE 1
 (-)XRD-01RMDCM3 Shown
 (-)XRD-01RMDDM3 Similar

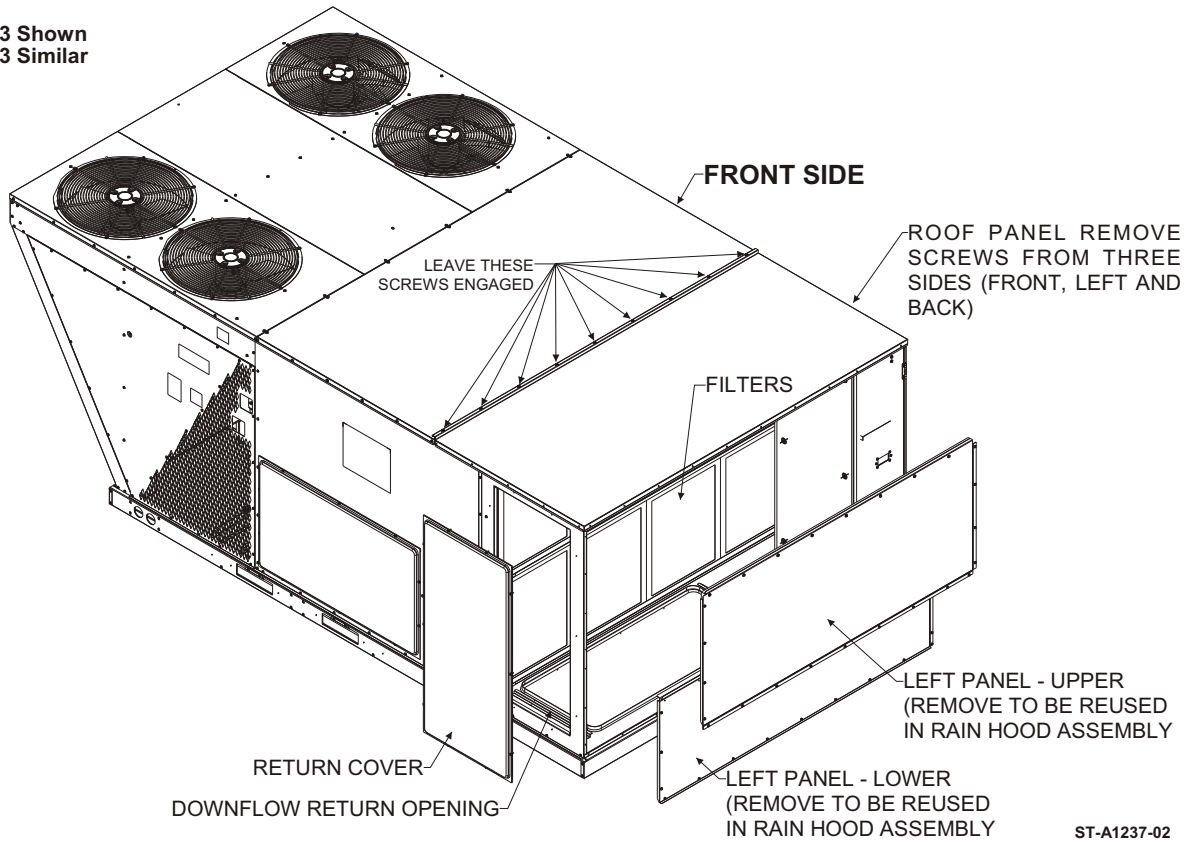

ST-A1237-02

STEP 1:

Immediately upon receipt, all cartons and contents should be inspected for transit damage. Units with damaged cartons should be opened immediately. If damage is found, it should be noted on the delivery papers and a damage claim filed with the last carrier. Compare carton(s) contents to PACKAGE CONTENTS List (TABLE 1) above to note any missing items.

STEP 2:

Remove RETURN COVER, LEFT PANEL – UPPER and LOWER PANELS – LEFT BOTTOM SECTION from the unit and retain for reuse (SEE FIGURE 1). Retain screws.

STEP 3:

Remove screws from 3 sides of ROOF PANEL so that it can be raised during economizer insertion.

NOTE 1:

Remove shipping bracket, ② PERMANENT FILTERS, ⑤ OA RAINHOOD - LEFT SIDE, ⑥ OA RAINHOOD - RIGHT SIDE, ⑦ EXHAUST AIR RAINHOOD - LEFT SIDE and ⑧ EXHAUST AIR RAINHOOD – RIGHT SIDE from fresh air opening. (SEE FIGURE 2).

STEP 4:

Remove jumper plug and slide economizer into unit return air section (SEE FIGURE 2). After the economizer is installed, connect unit ECONOMIZER PLUG to economizer mating plug. **01RMDCM3** - Reinstall jumper plug PL7 to PL21 (located on economizer). **01RMDDM3** - Save jumper plug PL7 in this compartment for diagnostic purposes.

FIGURE 2

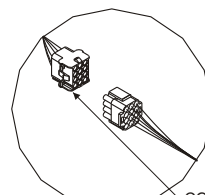
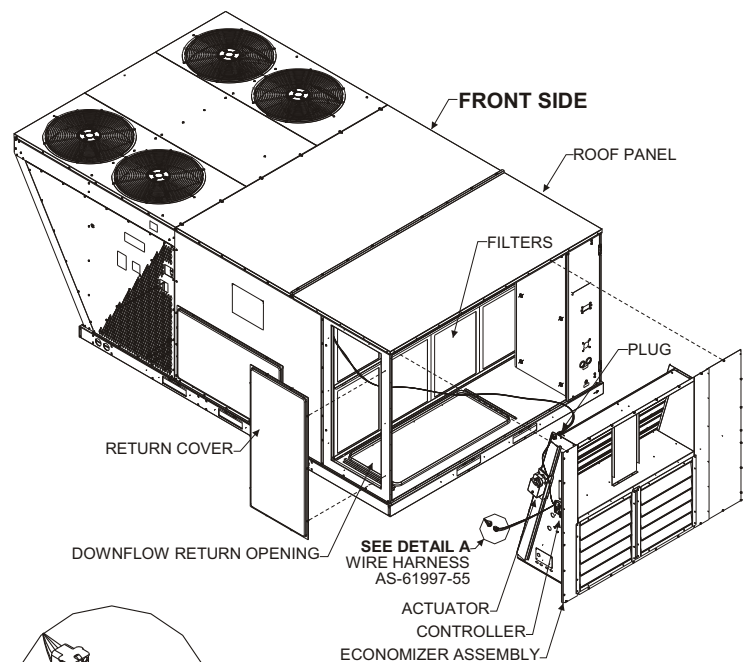

DETAIL A

CONNECT UNIT ECONOMIZER JUMPER PLUG TO ECONOMIZER IF SMOKE DETECTOR NOT USED

ST-A1237-05

STEP 5:

Secure economizer and ③ SPOTWELD ASSY - BIRD SCREEN along bottom with six screws as shown (SEE FIGURE 2). See TABLE 1 for identification.

STEP 6:

Fasten ⑦ EXHAUST AIR RAINHOOD - LEFT SIDE and ⑧ EXHAUST AIR RAINHOOD - RIGHT SIDE to barometric relief opening (lower opening) on the economizer (SEE FIGURE 3). Fasten with six screws. See FIGURE 4 for identification of EXHAUST AIR RAINHOODS.

STEP 7:

Fasten ④ EXHAUST AIR RAINHOOD ASSY - BIRDSCREEN FRONT SUPPORT under edge of LEFT PANEL - LOWER using six screws. Do not install a screw in the rightmost hole in the panels at this time.

STEP 8:

Fasten LEFT PANEL - LOWER and ④ EXHAUST AIR RAINHOOD ASSY - BIRDSCREEN FRONT SUPPORT to the top of the ⑦ EXHAUST AIR RAINHOOD - LEFT SIDE and ⑧ EXHAUST AIR RAINHOOD - RIGHT SIDE which was previously installed on the unit (SEE STEP 7).

STEP 9:

Attach ⑨ OA FILTER RAIL ASSY to economizer center support, ⑦ EXHAUST AIR RAINHOOD - LEFT SIDE and ⑧ EXHAUST AIR RAINHOOD - RIGHT SIDE and LEFT PANEL - LOWER using screws provided.

STEP 10:

Position the ⑩ OA RAINHOOD ASSY - TOP under edge of ROOF PANEL. Do not install screws at this time.

STEP 11:

Fasten ⑤ OA RAINHOOD - LEFT SIDE and ⑥ OA RAINHOOD - RIGHT SIDE to unit using screws provided (3 each on (-)XRD-01RMDCM3, and on (-)XRD-01RMDDM3).

STEP 12:

Slide ② PERMANENT FILTERS between ⑤ OA RAINHOOD - LEFT SIDE and ⑥ OA RAINHOOD - RIGHT SIDE back into the ⑨ OA FILTER RAIL ASSY.

STEP 13:

Fasten ⑪ OA RAINHOOD - FRONT FILTER SUPPORT to LEFT PANEL - UPPER with six screws. The bottom lip should support the ② PERMANENT FILTERS. Do not install a screw in the rightmost hole in the panels at this time.

STEP 14:

Fasten LEFT PANEL - UPPER to ⑤ OA RAINHOOD - LEFT SIDE and ⑥ OA RAINHOOD - RIGHT SIDE and ⑪ OA RAINHOOD - FRONT FILTER SUPPORT using 16 screws

STEP 15:

Re-secure ROOF PANEL using the washer head screws that were removed in STEP 3 from the ROOF PANEL.

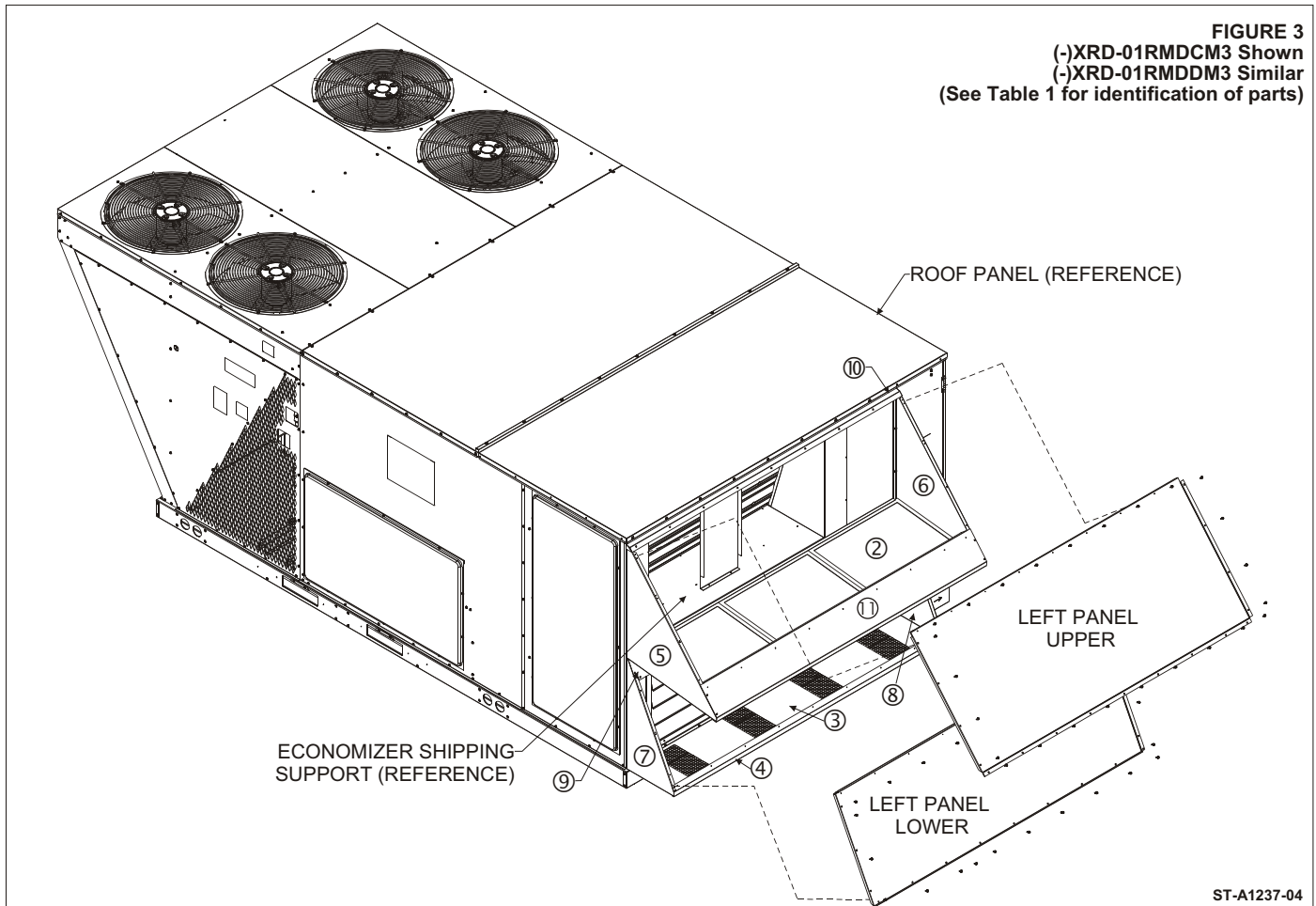
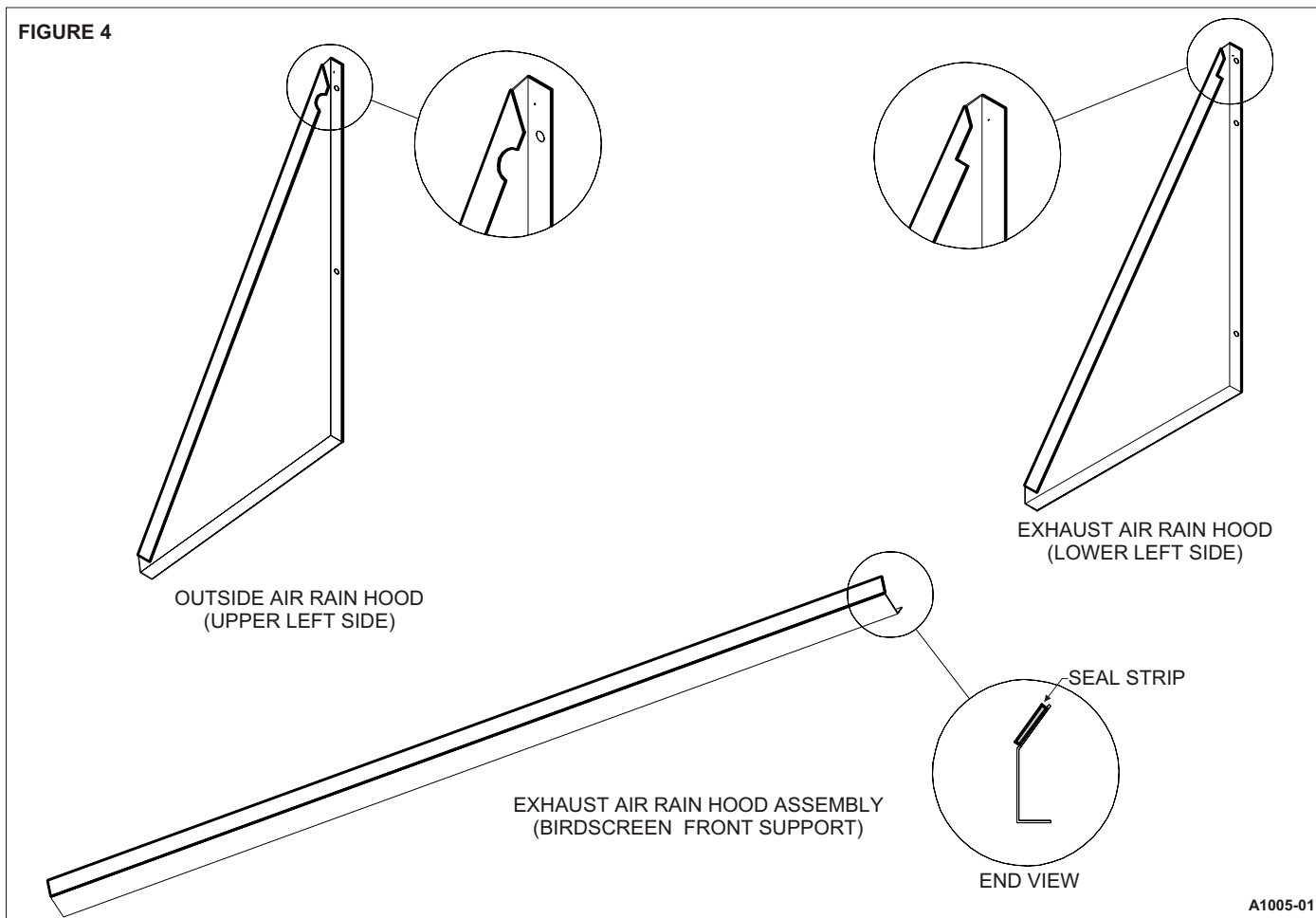

FIGURE 3
 (-)XRD-01RMDCM3 Shown
 (-)XRD-01RMDDM3 Similar
 (See Table 1 for identification of parts)

ST-A1237-04

FIGURE 4



STEP 16:

Upon start-up check the economizer sequence of operation using the steps provided in these instructions. After testing unit operation and setting outside air damper minimum position, replace RETURN COVER with remaining screws.

DIRECT MOUNT ECONOMIZER SEQUENCE OF OPERATION

GENERAL

This accessory economizer package is designed to save energy costs by using outdoor air for cooling and ventilation in place of mechanical cooling whenever possible. The economizer continuously monitors indoor and outdoor air conditions and compares them to a user-selected setpoint to determine if free cooling is available.

ACCESSORIES

RXXR-AV03 – Dual Enthalpy Upgrade Kit

For maximum energy savings, this upgrade kit will allow the economizer to compare the outdoor enthalpy to the return air enthalpy, instead of a user-selected setpoint to determine if "free cooling" is available.

RXXR-AR02 - Wall-Mounted Carbon Dioxide Sensor

For installations requiring Demand Control Ventilation (DCV) based upon indoor air levels of carbon dioxide (CO₂). When the unit supply fan is running, the CO₂ sensor modulates the outside air damper to maintain a user-selected CO₂ level inside the occupied space. Energy savings are achieved by not bringing in excessive amounts of outdoor air when the indoor air conditions are suitable. Energy savings can be substantial on buildings with highly variable occupancy rates.

Wall-Mounted Remote Potentiometer

For installations requiring remote adjustment of damper minimum position by the occupants, a remote potentiometer (270 ohm), such as the Honeywell S963B1136 can be used.

RXXR-BGF05C, RXXR-BGF05D, RXXR-BGF05Y – Power Exhaust Kit

For installations requiring more space static pressure relief than can be obtained with the standard barometric relief damper included with the economizer, a power exhaust kit can be added.

STARTUP

Attach 12-pin Rooftop unit wiring harness to 12-pin harness on economizer. Attach 4-pin Rooftop unit wiring harness directly to economizer logic module (ELM). A separate mixed air sensor is not required. It is supplied with the Rooftop unit and communicates the temperature and other information to the ELM via the 4-pin plug.

ADJUSTMENTS ON ELM CONTROLLER

3 potentiometers with screwdriver adjustment slots, starting from top of controller (See Figure 5).

Note: Before any adjustments are made, the Rooftop Unit Controller should be placed in "Occupied" Mode.

FIGURE 5

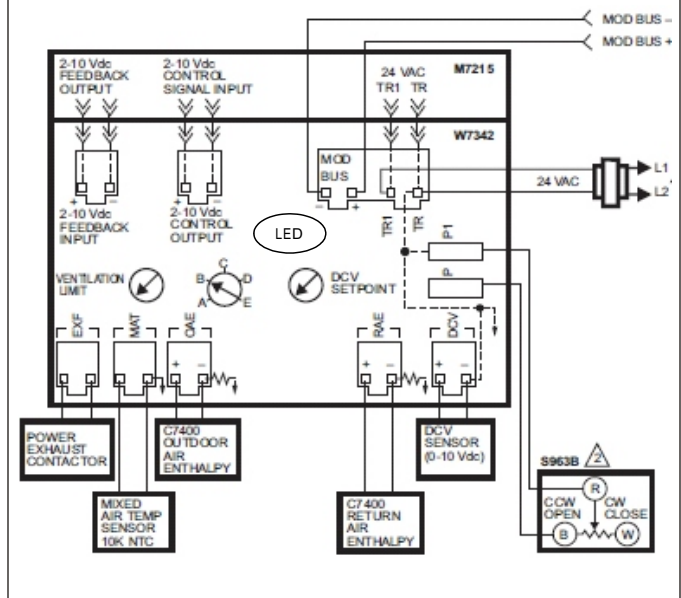

1. Ventilation Limit – Outside Air Damper minimum position
 - A. Adjust the Ventilation Limit potentiometer to allow the minimum amount of outdoor air, as required by local codes, to enter the building (See Figure 6). The CO₂ sensor, if present, should be disconnected or **DISABLED** during this step.

FIGURE 6

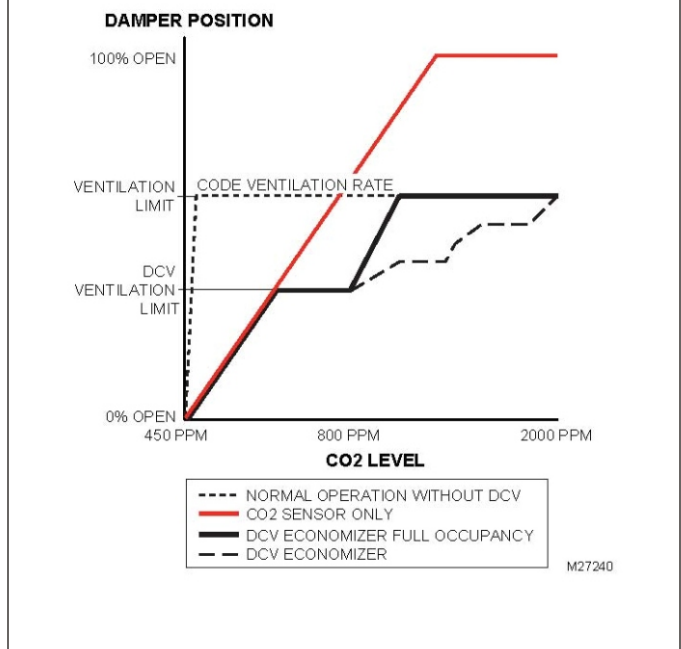

- B. Range of adjustment is from 0-100% (2-10Vdc output); in most applications the minimum position is adjusted to allow 10% to 25% outside air to enter the system.
- C. Whenever the supply fan signal is present, the damper will open to this minimum position unless:
 - i. It may modulate to a lesser position if overridden by the CO₂ sensor (DCV).
 - ii. It may not open if overridden by the discharge air temperature sensor (Freeze Protect Mode).
 - iii. The unit controller or communication network may override any adjustments made to the economizer controller. Adjustments may be made from the Rooftop Unit Controller keypad and display or the communication network and has priority over the potentiometer setting.

2. Economizer Setpoint

- A. Only the coolest, driest outside air is used for economizer operation when the potentiometer is on setting "E". For greatest energy savings, the potentiometer is on setting "A" (See Figure 7).

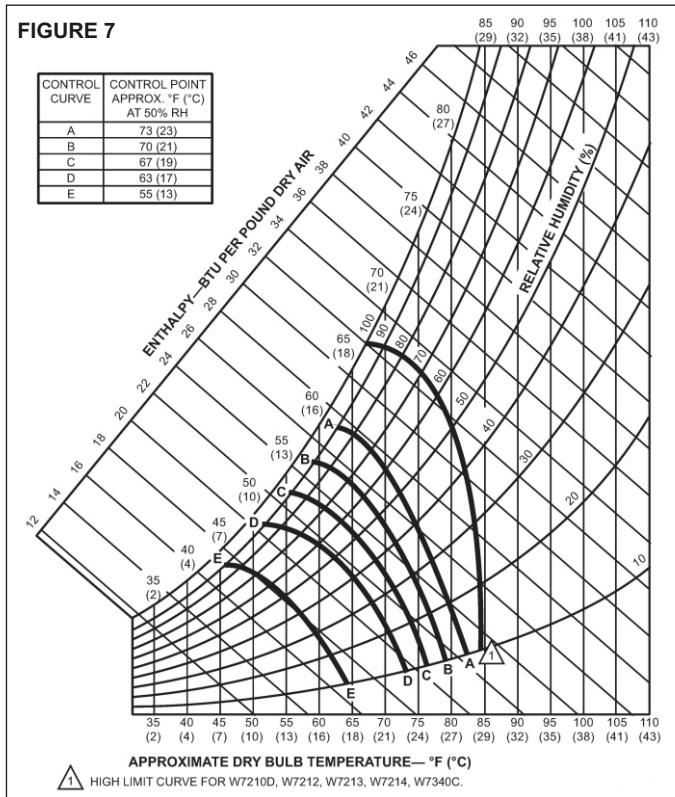

- B. Adjustment range is A, B, C, D, or E.
 - i. Setting "A" = 73°F db or 27 Btu/lbm @ 50% RH
 - ii. Setting "B" = 70°F db or 25 Btu/lbm @ 50% RH
 - iii. Setting "C" = 67°F db or 23 Btu/lbm @ 50% RH
 - iv. Setting "D" = 63°F db or 22 Btu/lbm @ 50% RH
 - v. Setting "E" = 55°F db or 18 Btu/lbm @ 50% RH

- C. Economizer Setpoint potentiometer can be adjusted at any time, but not through the Rooftop Unit Controller keypad or network.
- D. The controller compares the enthalpy sensor input with the economizer setpoint to determine if free cooling is available.
 - i. Single enthalpy strategy: If outdoor air enthalpy is lower than the setpoint, then free cooling is available.
 - ii. Dual enthalpy strategy: If outdoor air enthalpy is lower than return air enthalpy, then free cooling is available (if using dual enthalpy, the Economizer Setpoint must be at the "D" setting).

3. DCV Setpoint – Demand Control Ventilation (DCV) Setpoint

- A. The DCV can be any sensor that provides a 0-10Vdc output. The DCV modulates the outdoor damper to provide ventilation based on occupancy. Typically a carbon dioxide sensor (CO₂) is used to indirectly monitor occupancy level.
- B. No cooling signal is required for the DCV to override the outdoor air damper when ventilation requires outdoor air.
- C. The controller must receive a supply fan signal to open the damper.
- D. Range of adjustment is from 0 volts to 10 volts.
- E. The DCV setpoint can be adjusted at any time. The default setting is 50% of the Ventilation Limit setting.
- F. The Rooftop Unit Controller or communication network may override any adjustments made to the economizer controller and has priority over the potentiometer setting.
- G. The controller compares the CO₂ sensor input to the DCV setpoint to determine the damper minimum position. If a CO₂ sensor is present, the damper modulates between the DCV setpoint and the Ventilation Limit.
 - i. If the actual CO₂ level is below the setpoint, then the damper minimum position is determined by the DCV setpoint potentiometer setting.
 - ii. If the actual CO₂ level rises above the setpoint, then the damper minimum position is overridden proportionally more open to a maximum of the Ventilation Limit potentiometer setting.
 - iii. If the discharge air temperature drops below 48°F (Freeze Protect Mode), the DCV input will be overridden and the damper may not open.
- H. Compatible CO₂ sensors will have a 0-10Vdc output for a 0-2000 ppm CO₂ input.
 - I. Ensure proper polarity of the sensor wires when connecting to the economizer logic module (ELM). Incorrect polarity negates the sensor signal.

NORMAL OPERATION

1. Fan Only
 - A. Damper will go to minimum position (in 90 seconds or less) whenever the supply fan signal is present.
 - B. When supply fan signal is removed, the outside air damper closes against blade seals for a tight shutoff of outside air.
 - C. If the discharge air temperature drops below 48°F, then the control will override the minimum position setting and will modulate the outside air damper closed.
2. Call for First Stage of Cooling
 - A. Economizer Unavailable (warm outdoor air). Compressor 1 is commanded on without delay.
 - B. Economizer Available (free cooling). The controller tries to maintain a discharge air temperature of 53°F ± 5 by modulating the outside air damper position. Compressor 2 is not activated in the economizer mode.
3. Call for Second Stage of Cooling
 - A. Rooftop unit in Thermostat Control Mode
 - i. Economizer Unavailable (warm outdoor air). Compressor 2 is commanded on without delay.
 - ii. Economizer Available (free cooling). Compressor 1 is commanded on without delay. The controller tries to maintain a discharge air temperature of 53°F ± 5 by modulating the outside air damper position. Compressor 2 is not activated in the economizer mode.
 - B. Rooftop unit in Network Control Mode
 - i. Economizer Unavailable (warm outdoor air). Compressor 2 is commanded on without delay.
 - ii. Economizer Available (free cooling). Compressor 1 is commanded on without delay. The outside air damper position is held in the 100% open position until the call for second stage cooling is removed. The discharge temperature is ignored. Compressor 2 is not activated in the economizer mode.
4. Call for Heat
 - A. If the control detects that the supply fan is on, then the control will open the damper to minimum position.
 - B. If the discharge air temperature drops below 48°F, then the control will override the minimum position setting and will modulate the outdoor damper closed.

COMMUNICATION

The Rooftop Unit Controller communicates to the Economizer Logic Module (ELM) via the 4-pin Rooftop unit wiring harness under the RS485 (MODBUS® RTU) standard.

The table (**Table 2**) lists the values that are shown on the Rooftop Unit Controller Display and are communicated to the Economizer Logic Module (ELM). The Rooftop Unit Controller is the master device and sends requests to the ELM slave device which then responds.

	Economizer Menu On Rooftop Controller	Adjustable Range	Default setting
1	Econ. Status Economizer OK / Economizer Not OK	N/A	N/A
2	Econ. Status Diff Enthalpy / Single Enthalpy	N/A	N/A
3	Econ. Status Exh. Fan is ON/OFF	N/A	N/A
4	* Enthalpy Setpt. A / B / C / D / E	A/B/C/D/E	A
5	Eff.Mix.Air Temp XXX.X °F	N/A	N/A
6	* Mixed Air Setpt. XXX.X °F	0 - 99	53
7	Ext.Mix.Air Temp XXX.X °F	N/A	N/A
8	* Econ. Vent. Limit XXX %	0 - 100	0
9	* Econ.Exh. ON/OFF XXX %	0 - 100	50
10	* Econ. DCV Limit XXX %	0 - 100	0
11	* DCV Control Enabled / Disabled	Enabled / Disabled	Disabled
12	* DCV Level Setpt. XXXX ppm	500 - 2000	700
13	Ext. DCV Level XXXX ppm	N/A	N/A
14	Eff. DCV Level XXXX ppm	N/A	N/A
15	Eff.Eco.Position XXX %	N/A	N/A
16	Eff.Min.Position XXX %	N/A	N/A
17	Local. Min. Pos. XXX %	N/A	N/A
18	Econ. Faults DCV Sensor Fault OAE Sensor Fault RAE Sensor Fault MAT Sensor Fault Actuator Fault	N/A	N/A
19	Econ Firm Vrsn	N/A	0103
20	* Smoke Detector	Standard Purge w/Heat Exhaust Purge Pressurize	Standard

TABLE 2

*MENUS THAT ARE USER ADJUSTABLE

1. Econ. Status. Displays whether the enthalpy is acceptable for economization.
2. Econ. Status. Displays whether the system is using single or differential enthalpy.
3. Econ. Status. Displays the status of the optional power exhaust fan (if connected).
4. Enthalpy Setpoint. Displays the five levels the user must choose for the enthalpy set point. Figure 7 indicates what each of those levels represents in the psychometric chart. This setting determines the level at which economization is allowed. If Dual Enthalpy Control is used, the setting must be "D".

5. Eff. Mix. Air Temp. Displays the current value of mixed air temperature.
6. Mix Air Setpt. When the mixed air temperature falls below this set point, the freeze protection control will disable the mixed air control and close the outdoor damper to the effective minimum position.
7. Ext. Mix. Air Temp. Displays the discharge air temperature reading from the Rooftop Unit Controller.
8. Econ. Vent. Limit. Displays the minimum acceptable outside-air ventilation rate as a percentage of outdoor air damper position. The volumetric flow-rate of outside air required can be determined from building codes, ASHRAE standards, or standard practice. The use of a CO₂ sensor can lower the minimum outdoor air quantity as described in the next section for Demand Control Ventilation (DCV). The system allows the adjustment of the ventilation limit through four different methods, listed below in order of priority:
 - A. Network interface (BACnet® or Lonworks®)
 - B. Rooftop Unit Controller Display and Keypad
 - C. Remote potentiometer
 - D. Direct adjustment through the Ventilation Limit potentiometer on the ELM control.
9. Econ. Exh. ON/OFF. Display allows the user to change the set point of what percentage of outside air damper position the exhaust fan is energized. The default value is 50% of full outside air.
10. Econ. DCV Limit The economizer will allow the dampers to close more than the minimum position if the indoor air quality is not contaminated. The Econ. DCV Limit can be set from 0 to 100% but must be lower than the Ventilation Limit setting. The default value is 50% of the Ventilation Limit setting.
11. Econ. DCV Control. If connected to a CO₂ sensor, the ELM regulates the amount of outdoor air supplied to the space to maintain the level of carbon dioxide below the recommended 700ppm above the outdoor level. In this case, CO₂ levels serve as a proxy for building occupancy and the rate of human-generated indoor pollutants. Once the DCV is operating, the minimum damper position can then be lowered to the DCV Setpoint. By default, this value is 50% of the ventilation limit, but the user has the option to adjust it through network or Rooftop Unit Controller keypad and display. The user also has the option to disable DCV altogether.
12. DCV Level Setpt. The DCV level setpt is a selectable level of carbon dioxide that system does not allow to be exceeded. The set point is communicated to the economizer and the minimum ventilation position is changed in order to prevent the increase of CO₂.
13. Ext. DCV Level. Displays the value the Rooftop Unit Controller sends to the Economizer (used with networked CO₂ sensors not connected directly to the economizer).
14. Eff. DCV Level. Displays the actual DCV Level (CO₂ level) in ppm.
15. Eff. Eco. Position. Displays the actual position of the economizer outside air damper.
16. Eff. Min Pos. Displays the current value of the effective minimum outside air damper position.
17. Local Min. Pos. Displays the local ventilation limit position that is set at the ELM.
18. Econ Faults. Displays any ELM sensor faults.
19. Econ Firm Vrsn. Displays the build date and the software version installed on the ELM.

20. Smoke Detector: Displays the response of the economizer and unit during a smoke detector alarm. A password must be entered to change the setting.

Component	Smoke Detector Setting				
	Standard	Purge w/Heat	Exhaust	Purge	Pressurize
Indoor Blower	0%	100%	100%	100%	100%
Compressor	OFF	OFF	OFF	OFF	OFF
Gas/Electric Heating allowed?	NO	YES	NO	NO	NO
Economizer OA Position	0%	100%	0%	100%	100%
Power Exhaust	OFF	ON	ON	ON	OFF

Notes: In Standard Mode, an emergency stop command is issued for a VFD (variable speed drive) equipped unit to stop the indoor blower immediately rather than ramping down to a stop.

TROUBLESHOOTING

The ELM status LED (See Figure 5) will be:

1. On steady when economizer is operating normally.
2. On and off (blinking) occurs 20 seconds after the economizer senses a fault in the system, e.g. no signal from sensor, no communication from Rooftop Unit Controller. Check Rooftop Unit Controller Display for fault readout.
3. Off when the economizer does not have power.

When diagnosing the system, the best results are obtained by first putting the fan setting for Thermostat Controlled units to the "Continuous Fan" mode. For Network controlled units, the Rooftop Unit Controller should be set to the "Occupied Mode".

NOTES

1. The mist eliminator (Permanent Outdoor Air Filter) is of aluminum mesh construction and should be cleaned by flushing regularly with warm soapy water. The replacement mist eliminator size is listed on the first page of these instructions.
2. Operation of the optional power exhaust only depends upon the supply fan running and the damper position (it is possible to set the minimum position high enough to engage the power exhaust in the heating mode).
3. For operation in Thermostat mode, this economizer requires a two-stage thermostat.
4. Upon loss of power to the unit or economizer, the outside air damper will spring close shut in about 5 seconds.
5. Compressor Time Delays, Compressor Interstage Delays, Compressor Low Ambient Lockouts, etc. are not provided by the economizer controller.
6. If DCV is **DISABLED** and a CO₂ sensor is connected to the economizer, the CO₂ level will still display on the Rooftop Unit Controller, but will not be used for control.

HARNESS ENDS AT PL21 & PL20

COMPONENT CODE

C7400C Fresh Air Sensor
 J2 Power Exhaust Cap
 MS7106K Damper Actuator 24v
 PL6 Male A/C Unit Plug
 PL7 Female A/C Unit Plug
 PL20 Female Economizer Cap
 PL21 Male Smoke Plug
 W7342A Logic Module

WIRE COLOR CODE

BLK Black BLU Blue
 BRN Brown GRN Green
 GRY Gray ORG Orange
 PNK Pink RED Red
 TAN Tan VIO Violet
 WHT White YEL Yellow

Revision	Change	Date
A	Added Material List for 303H14	05-26-10
B	ECN# 6464	05-01-13
C	Changed wiring diagram	08-14-15

CONNECTOR & CONTACT CONFIGURATION
 PL7 (300000297) CAP - (300000558) SOCKET
 J2 (300000291) CAP - (300000558) SOCKET

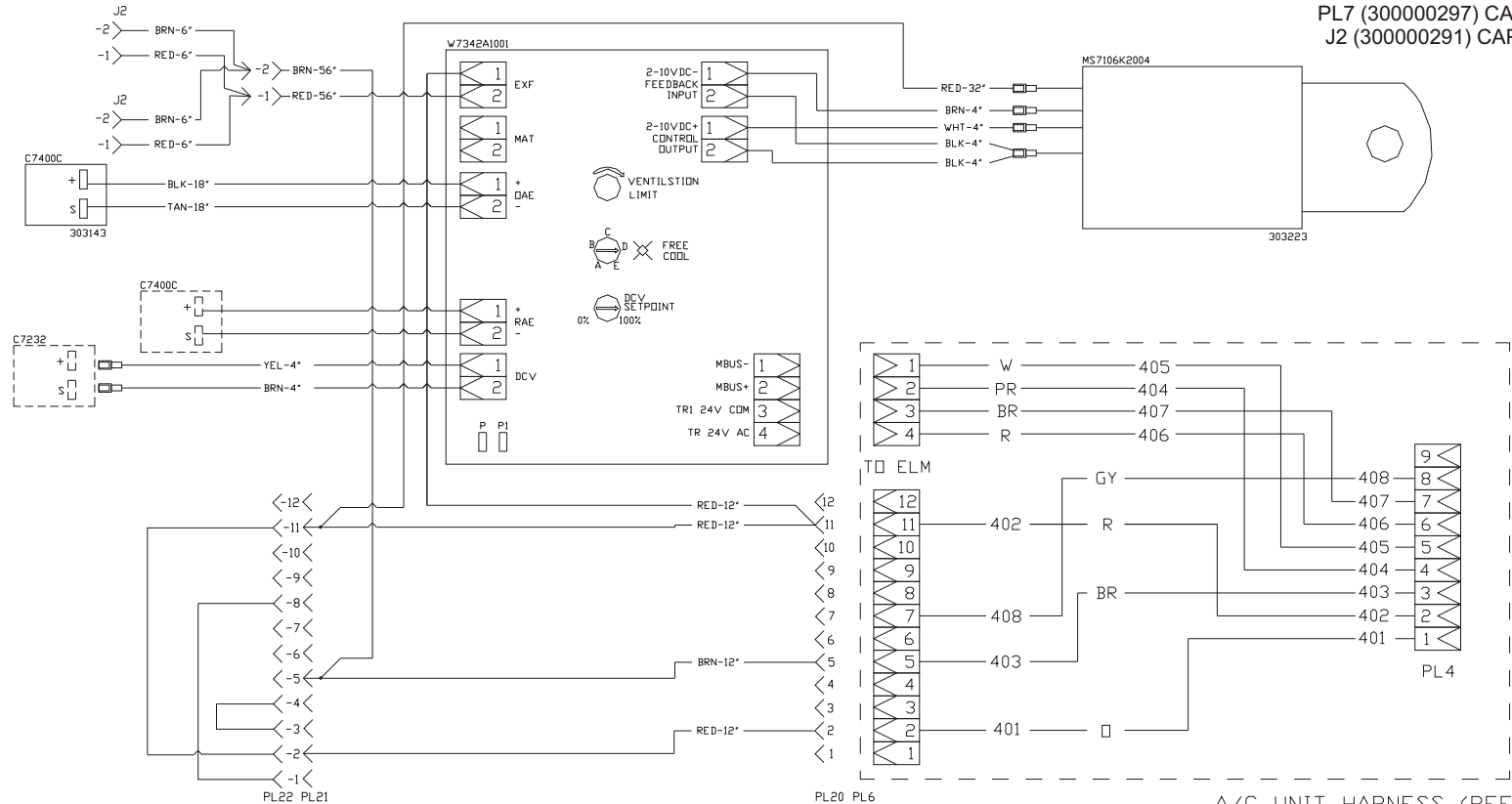

Notes:

1. Unit wiring shown as reference only. Check unit wiring for actual unit wiring.
2. Relays 1K and 2K actuate when the Outdoor Air Enthalpy is lower than the Return Air Enthalpy.
3. 1S is an electronic switch which closes when powered by a 24 VAC input.
4. Factory installed resistor should be removed only if C7400 Differential Enthalpy Sensor is added.
5. Y2 must be energized for the compressor to operate.

**Modulating Gear Economizer
 RKNL / RLNL 180-300**



1625 Diplomat Drive
 Carrollton, Texas 75006
 Phone (972) 247-7447
 Fax (972) 243-0940

Date: August 14, 2015
 Supersedes: 05-01-13
 Drawn by: JP
 Unit #: 60-36D-16
 Diagram#: 6036D16W
 Approved by:

HARNESS ENDS AT PL21 & PL20

COMPONENT CODE

C7400C Fresh Air Sensor
 J2 Power Exhaust Cap
 MS7106K Damper Actuator 24v
 PL6 Male A/C Unit Plug
 PL7 Female A/C Unit Plug
 PL20 Female Economizer Cap
 PL21 Male Smoke Plug
 W7342A Logic Module

WIRE COLOR CODE

BLK	Black	BLU	Blue
BRN	Brown	GRN	Green
GRY	Gray	ORG	Orange
PNK	Pink	RED	Red
TAN	Tan	VIO	Violet
WHT	White	YEL	Yellow

Revision	Change	Date
A	Added Material List for 303H14	05-26-10
B	ECN# 6466	05-01-13
C	Changed wiring diagram	08-14-15

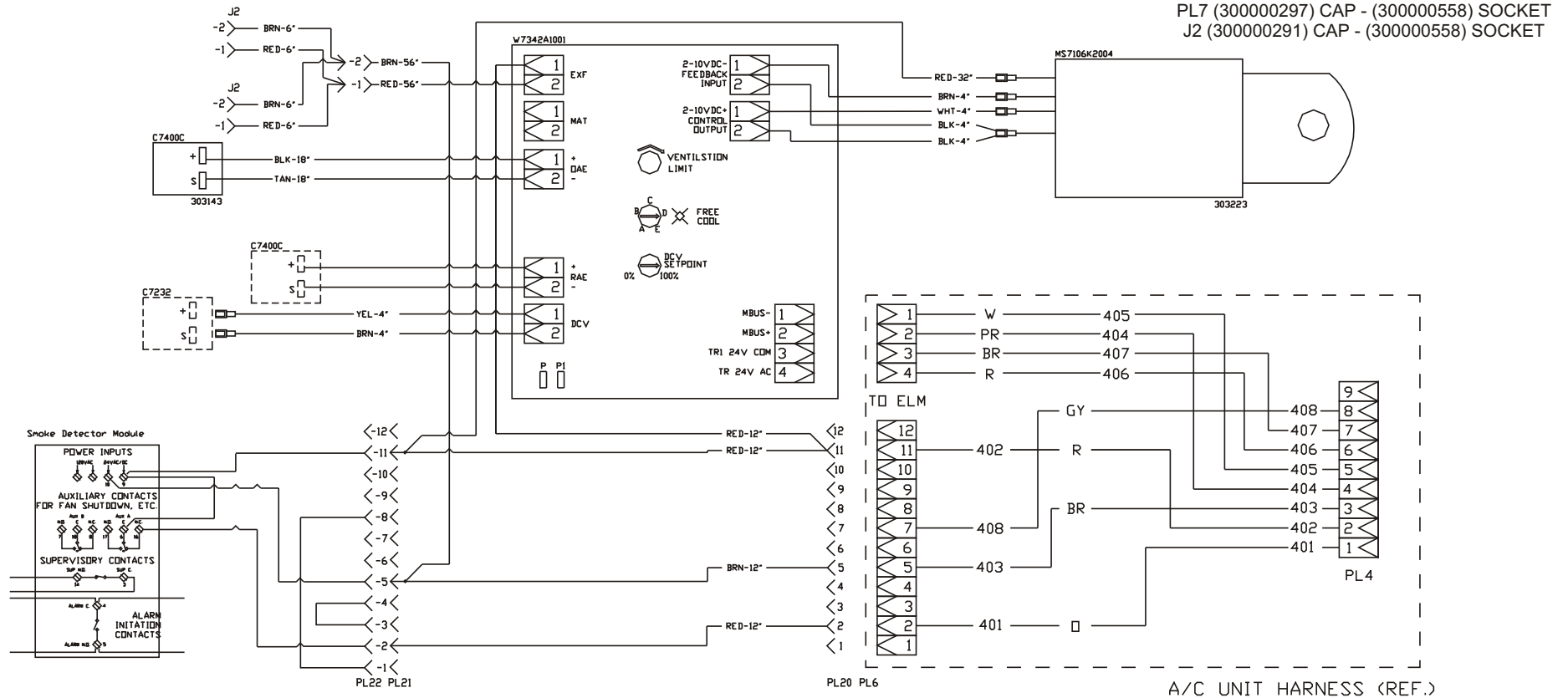

CONNECTOR & CONTACT CONFIGURATION
 PL7 (300000297) CAP - (300000558) SOCKET
 J2 (300000291) CAP - (300000558) SOCKET

Notes:

- Unit wiring shown as reference only. Check unit wiring for actual unit wiring.
- Relays 1K and 2K actuate when the Outdoor Air Enthalpy is lower than the Return Air Enthalpy.
- 1S is an electronic switch which closes when powered by a 24 VAC input.
- Factory installed resistor should be removed only if C7400 Differential Enthalpy Sensor is added.
- Y2 must be energized for the compressor to operate.

**Modulating Gear Economizer
 RKNL / RLNL 180-300**



1625 Diplomat Drive
 Carrollton, Texas 75006
 Phone (972) 247-7447
 Fax (972) 243-0940

Date: August 14, 2015
Supersedes: 05-01-13
Drawn by: JP
Unit #: 60-36D-16S
Diagram#: 6036D16SW
Approved by: