

# INSTALLATION INSTRUCTIONS

## MODEL# RXXR-DDCAE

### ADAPTER CURB

**STEP 1:**

Immediately upon receipt the adapter curb package should be checked for transit damage. If damage is detected, it should be noted on the delivery papers and a damage claim filed with the last carrier. Compare adapter curb contents to PACKAGE CONTENTS List (TABLE 1) to note any missing parts.

Table 1 - Package Contents			
ITEM	DESCRIPTION	QTY	RXXR-DDCAE Curb Adapter
1	Adapter curb assembly (a)	1	
2	Adapter curb deck pan (b)	1	
3	Adapter curb gasket 1/4" x 1 1/2" x 16' (c)	5	

**Step 2:**

Verify that roof structure is capable of safely supporting the adapter curb and the new HVAC unit. Reinforce as required following all applicable building codes.

**Step 3:**

Be sure all power sources and utilities are disconnected from unit. Remove unit from the roof and discard per applicable codes.

**Step 4:**

The adapter curb (a) is designed to fit only the existing curb shown below in **FIGURE 1**. Confirm that the curb on the job site is the same as is shown in **FIGURE 1**. If dimensions or orientation are different, adapter curb will not fit onto existing curb.

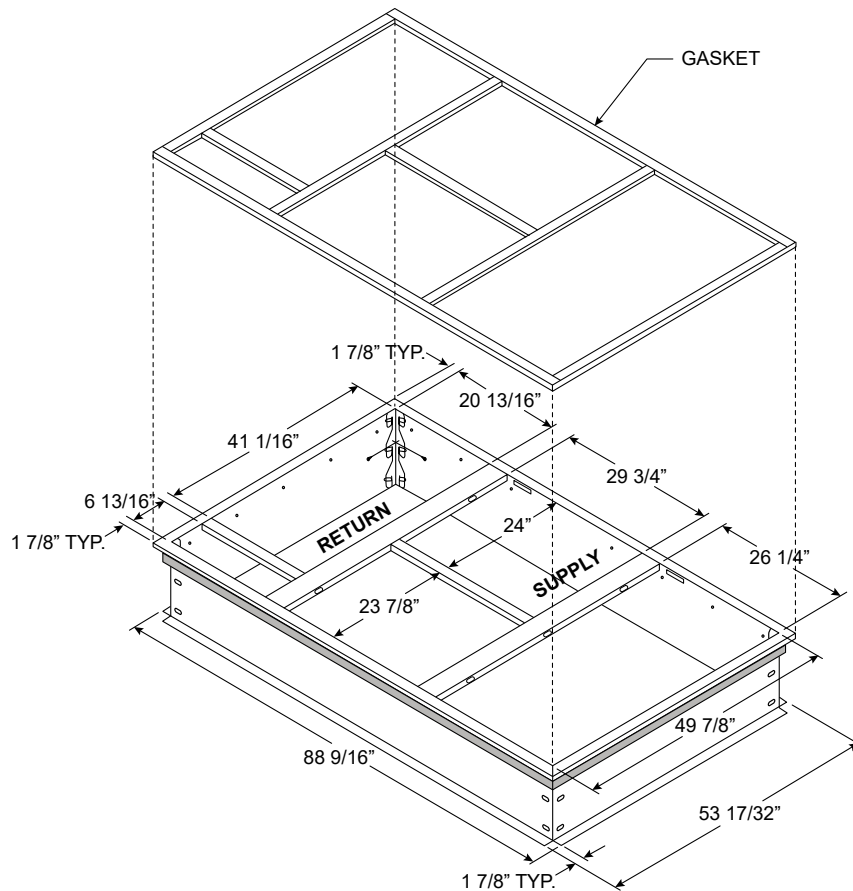

**Figure 1 - Existing Curb**

**Step 5:**

Remove any residual gasket from the top flange of the existing curb. Install provided gasket (c) around top perimeter and duct openings on existing curb, **SEE FIGURE 1**. Set adapter curb (a) in place on top of the existing curb. Be sure the duct alignment orientation is as shown in **FIGURE 2**. Ensure there is no air leakage between adapter curb and existing duct – caulk seams as necessary.

**STEP 6:**

Caulk the up-flange on edge of adapter curb. Set adapter curb deck pan (b) in place over existing curb as shown in **FIGURE 2**. Screw adapter curb up-flange and deck pan together ensuring a watertight seam.

**STEP 7:**

Install gasket (c) on top perimeter and around duct openings on curb adaptor (**See FIGURE 2**).

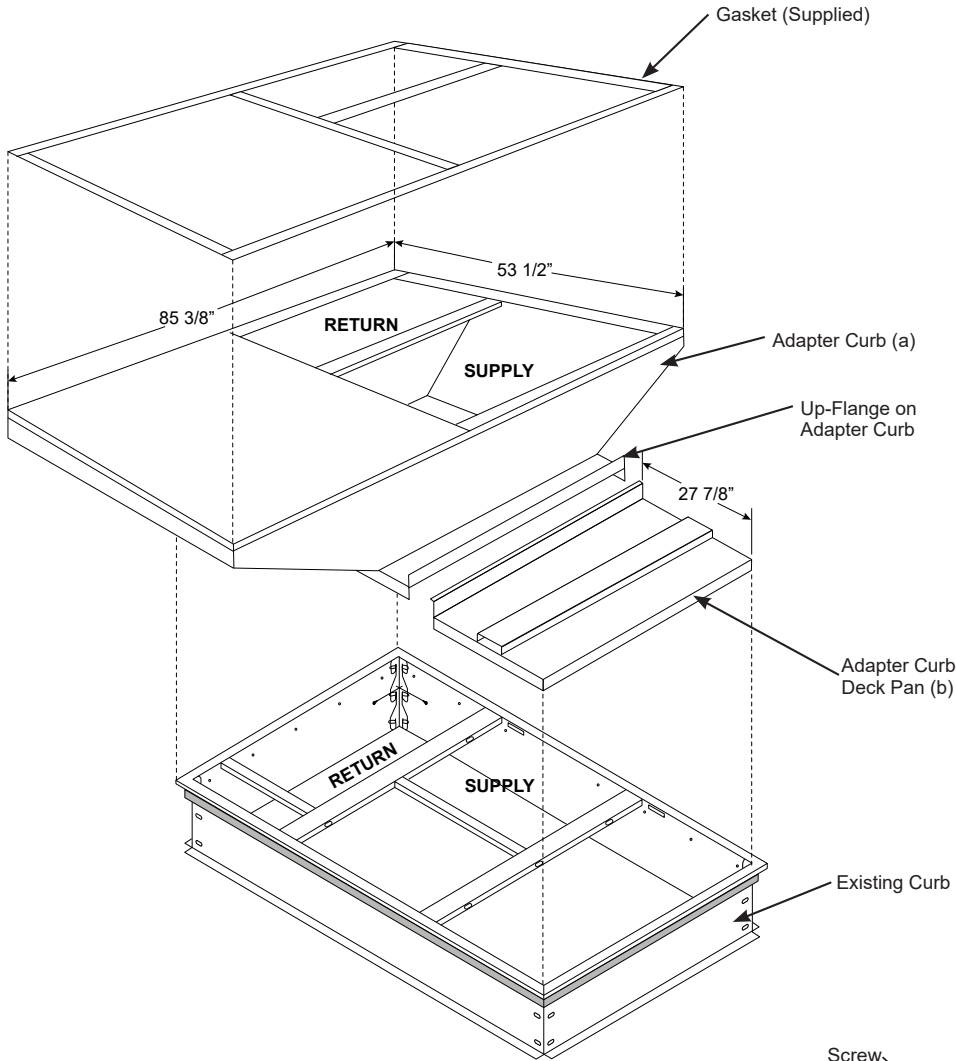

**Figure 2**

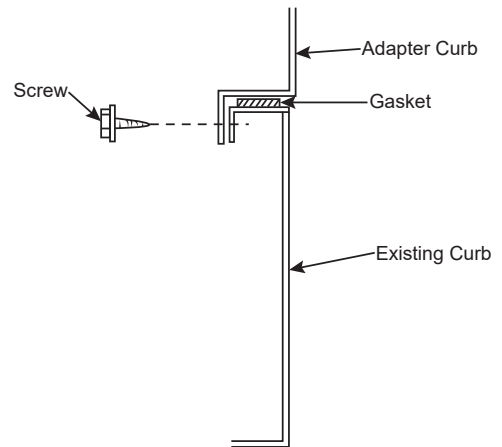

**Figure 3**

**STEP 8:**

Screw adapter curb's vertical overhang flange to the existing curb, **SEE FIGURE 3**.

**STEP 9:**

Set unit in place on top of adapter curb. Connect utilities to unit. Follow all unit instructions for unit startup.