



PACKAGE GAS / ELECTRIC ROOFTOP UNITS

FORM NO. R22-835 REV. 7
Supersedes Form No. R22-835 Rev. 6

RKKA- STANDARD EFFICIENCY SERIES
NOMINAL SIZES 3-7.5 TONS [10.6-26.4 kW]
(3 PHASE ONLY)

RKMA- HIGH EFFICIENCY SERIES
NOMINAL SIZES 6 TON [21.1 kW]
(3 PHASE ONLY)





Engineering Features	3
Introduction	4
Selection Procedure	5
Model Identification Options	6-9
General Data	
RKKA- Series	10-33
RKMA- Series	34-36
General Data Notes	37
Performance Data	
RKKA- Series	38-40
RKMA- Series.....	41
Airflow Performance	
RKKA-/RKMA- Series	42-50
Electrical Data	
RKKA- Series	51-56
RKMA- Series	57-58
Dimensional Data	59-64
Accessories	65-74
Typical Wiring	75-80
Limited Warranty	82

ENGINEERING FEATURES

RKKA/RKMA- Series Gas Heat / Electric Cooling Units

1. All models feature Scroll® compressors offering maximum reliability, efficiency, and quiet operation. The 6 and 7.5 ton [10.6 & 26.4 kW] model features two-stage cooling.
2. Aluminized steel heat exchanger with in-shot burners helps eliminate corrosion. Stainless steel heat exchangers optional.
3. Integrated blower/burner control board with built-in diagnostic capability permits on-site trouble shooting.
4. One-piece top over the indoor section with drip lip, drawn painted base pan, and 1" [25.4 mm] raised flanges for supply/return air connections provides superior water management.
5. Convertible horizontal and vertical airflow design allows maximum field flexibility and minimizes inventory requirements.
6. Standard full perimeter forkable 14 gauge baserail with lifting holes for easier maneuvering and installations.
7. Factory installed one-inch [25.4 mm] throw away filter with provisions for two-inch [50.8 mm] filter and two-inch [50.8 mm] filters for 7.5 ton [26.4 kW] models.
8. Direct or belt drive options to accommodate a wide range of design conditions as high as 1.5 inches [.37 kPa] of external static pressure. 6 & 7.5 ton [10.6 & 26.4 kW] models available with belt drive only.
9. Easily removable filter, blower, gas heat, and compressor/control access panels permits prompt service.
10. Number and color coded wiring helps facilitate service and maintenance.
11. Common cabinet and components allows for installation flexibility and fewer parts to inventory.
12. Standard freezestat control offers evaporator coil freeze protection. (Optional for 7.5 ton [26.4 kW] models).
13. Standard high and low pressure controls on high efficiency models and a factory or field installed option on standard efficiency models.
14. Externally mounted refrigerant gauge ports for easy service diagnostics.
15. Side and base electric power and gas connection entry helps minimize roof penetrations.
16. Quick assembly common roof curbs helps save field labor and maximize size flexibility.
17. Easy to install, plug-in, slip-in, 100% fully modulating economizers.
18. Quality powder paint finish offers long lasting protection against extreme weather conditions and is able to withstand 1000 HR salt spray test.

[] Designates Metric Conversions

These quality features are included in the Ruud Gas Heat / Electric Cooling Package Unit

Evaporator Coil/Filter Access

- Return air filters, normally provided, are removed in this photo.



- Non-corrosive plastic condensate pan



Tubular Heat Exchanger

- Aluminized steel (viewed from supply air side panel.)
- Stainless steel available

Control Box Access



Compressor Access (3 to 6 Ton [10.6 to 21.1 kW] Models)



Compressor Access (7.5 Ton [26.4 kW] Models)

- Dual compressors (available in 6 and 7.5 ton [10.6 and 26.4 kW] models only) provide two-stage cooling.

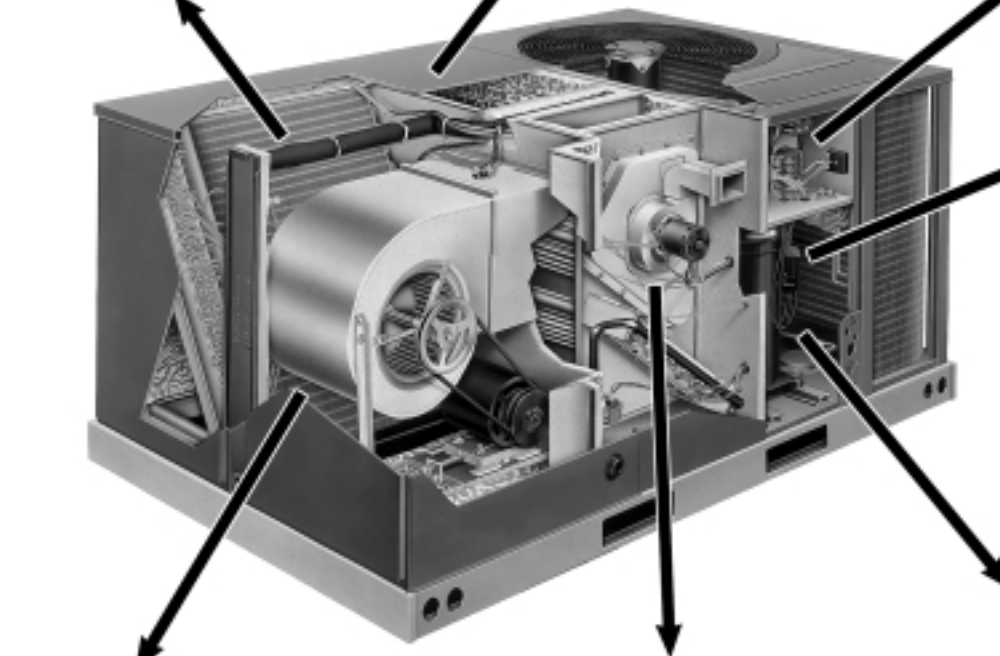

Blower Access

- Belt drive model shown. (Available on 3-phase models only.)



Heating Compartment Access



1. Determine cooling and heating requirements at design conditions.

Example:

- Total cooling capacity43,600 BTUH [12.78 kW]
- Sensible cooling capacity34,000 BTUH [9.96 kW]
- Heating capacity96,000 BTUH [28.13 kW]
- Condenser entering air95°F [35°C]
- Evaporator entering air63°F [17°C] wb/76°F [24°C] db
- Indoor air flow1600 CFM [755 L/s]
- External static pressure.....1.1 in wg
- Required efficiency12 SEER

2. Select unit to meet cooling requirements.

Since total cooling is within the range of 4 ton [14.07 kW] unit and requires 12 SEER efficiency level, enter cooling performance from the RDKA-A048 at 95°F [35°C] outdoor temperature, 63°F [17°C] wb entering indoor air, and 1600 CFM [755 L/s]:

- Total capacity46,600 BTUH [13.66 kW]
- Power input4.2 kW

And also, at 76°F [24°C] db indoor entering air, and using the formula at the bottom of the table:

- Sensible capacity36,646 BTUH [10.74 kW]

3. Select heating capacity of the unit.

In the general data tables, note that the heating capacity of the 4 ton [14.07 kW] model with the 135,000 input heater can deliver 106,500 BTUH [31.21 kW], which is suitable for this application.

4. Determine blower speed and power to meet the system requirements.

At the given external static pressure of 1.1 in wg, the belt model must be selected. Enter the belt drive blower performance data at 1600 CFM [755 L/s] and 1.1 in wg ESP:

- RPM1195
- Watts.....755
- DriveM

5. Calculate indoor blower BTUH heat effect.

BTUH = Watts x 3.413 = 2577

6. Calculate net cooling capacities.

Net total cooling = 46,600 – 2577 = 44,023 BTUH [12.90 kW]
 Net sensible cooling = 36,646 – 2577 = 34,069 BTUH [9.98 kW]

[] Designates Metric Conversions

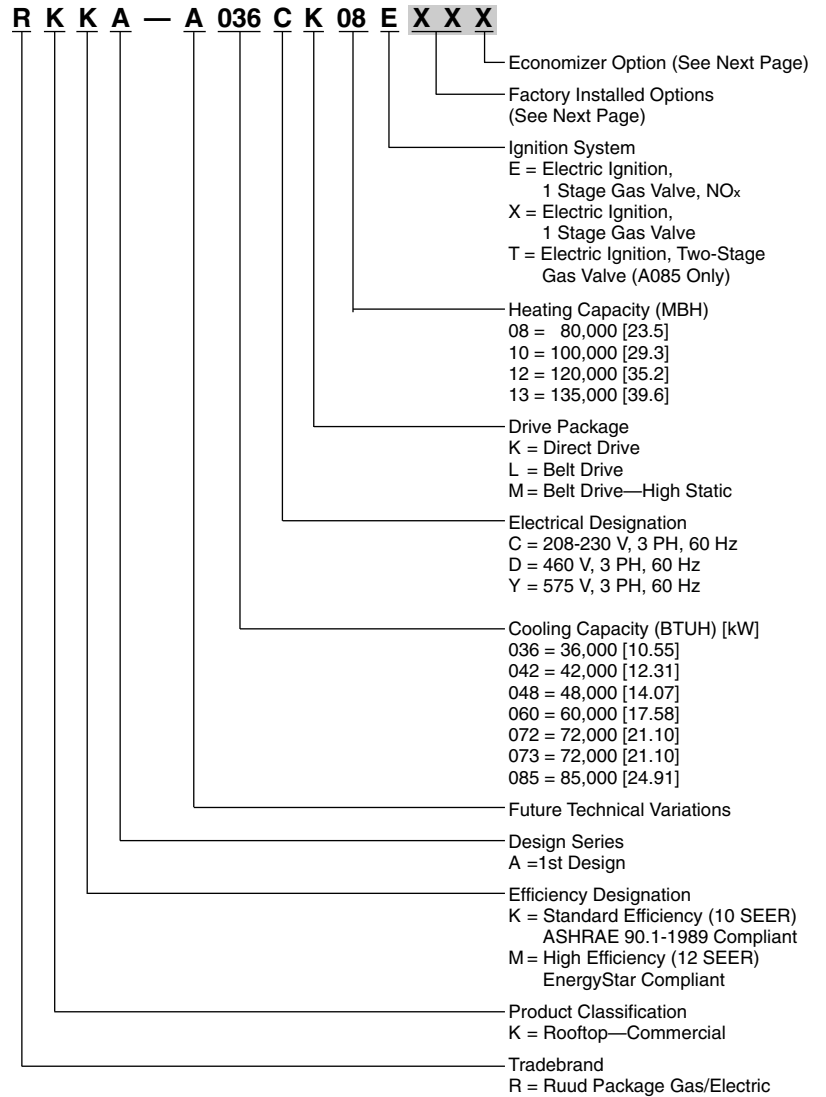

[] Designates Metric Conversions



**FACTORY INSTALLED OPTION CODES FOR RKKA
(3-5 TON AND 7.5 TON) [10.6-17.6 kW and 26.4 kW]
(A036, A042, A048, A060, A085)**

Option Code	High and Low Pressure	Hail Guard	Low Ambient Time Delay	Unwired Convenience Outlet Unfused Service Disconnect	Stainless Steel Heat Exchanger	Side Flow	Reduced Height Baseraills
AA	No Options						
AC	x						
AD		x					
AE			x				
AH				x			
AJ					x		
AK						x	
AL							x
BB	x	x					
BE	x		x				
BF		x		x			
BG		x			x		
BH			x	x			
BS		x				x	
BU	x					x	
BV					x	x	
BX		x					x
CA	x	x			x		
CB	x	x	x				
CE	x	x				x	
CP	x	x					x
DA	x	x	x	x			
DB	x	x	x		x		
EB	x	x	x	x	x		

Example: RKKA-A060CL13E**XXX** (where **XX** is factory installed option)

Example: No Options

RKKA-A060CL13E

Example: No option with factory installed economizer

RKKA-A060CL13EAAB

Example: Options with high and low pressure and hailguard, no factory installed economizer

RKKA-A060CL13EBBA

Example: Options same as above with factory installed economizer

RKKA-A060CL13EBBB

[] Designates Metric Conversions

FACTORY INSTALLED OPTION CODES FOR RKKA (6 TON) [21.1 kW] (A073)

Option Code	Hail Guard	Low Ambient Time Delay	Unwired Convenience Outlet Unfused Service Disconnect	Stainless Steel Heat Exchanger	Side Flow	Reduced Height Baserails
AA	No Options					
AD	x					
AE		x				
AH			x			
AJ				x		
AK					x	
AL						x
BC	x	x				
BF	x		x			
BG	x			x		
BH		x	x			
BS	x				x	
BV				x	x	
BX	x					x
CF	x	x	x			
CG	x	x		x		
DC	x	x	x	x		

Example: RKKA-A073CL13E**XX** (where **XX** is factory installed option)

Example: No Options

RKKA-A073CL13E

Example: No option with factory installed economizer

RKKA-A073CL13EAAB

Example: Options with hailguard, low ambient and time delay with no factory installed economizer

RKKA-A073CL13EBCA

Example: Options same as above with factory installed economizer

RKKA-A073CL13EBCB

[] Designates Metric Conversions



FACTORY INSTALLED OPTION CODES FOR RKMA (6 TON) [21.1 kW] (A072)

Option Code	Hail Guard	Low Ambient Time Delay	Unwired Convenience Outlet Unfused Service Disconnect	Stainless Steel Heat Exchanger	Side Flow
AA	No Options				
AD	x				
AE		x			
AH			x		
AJ				x	
AK					x
BC	x	x			
BF	x		x		
BG	x			x	
BH		x	x		
BS	x				x
BV				x	x
CF	x	x	x		
CG	x	x		x	
DC	x	x	x	x	

Example: RKMA-A060CL13E**XX** (where **XX** is factory installed option)

Example: No Options

RKMA-A060CL13E

Example: No option with factory installed economizer

RKMA-A060CL13EAAB

Example: Options with stainless steel heat exchanger and no factory installed economizer

RKMA-A060CL13EAJA

Example: Options same as above with factory installed economizer

RKMA-A060CL13EAJB

ECONOMIZER SELECTION FOR RKKA & RKMA, RKMB & RKNB (7.5 TO 15 TON) [26.4 TO 52.8 kW]

	No Economizer	Single Enthalpy Economizer With Barometric Relief
A	x	
B		x

“x” indicates factory installed option.

[] Designates Metric Conversions



NOM. SIZES 3-7.5 TONS [10.6-26.4 kW] ASHRAE 90.1-1999 COMPLIANT MODELS

Model RKKA- Series	A036CK08E	A036CK12E	A036CL08E	A036CL12E
Cooling Performance¹				
	CONTINUED →			
Gross Cooling Capacity Btu [kW]	37,600 [11]	37,600 [11]	37,600 [11]	37,600 [11]
EER/SEER ²	9.4/10.2	9.4/10.2	9.4/10.2	9.4/10.2
Nominal CFM/ARI Rated CFM [L/s]	1200/1200 [566/566]	1200/1200 [566/566]	1200/1200 [566/566]	1200/1200 [566/566]
ARI Net Cooling Capacity Btu [kW]	36,000 [10.5]	36,000 [10.5]	36,000 [10.5]	36,000 [10.5]
Net Sensible Capacity Btu [kW]	26,500 [7.8]	26,500 [7.8]	26,500 [7.8]	26,500 [7.8]
Net Latent Capacity Btu [kW]	9500 [2.8]	9500 [2.8]	9500 [2.8]	9500 [2.8]
Net System Power kW	3.8	3.8	3.8	3.8
Heating Performance (Package Gas/Electric)⁴				
Heating Input Btu [kW] (1st Stage / 2nd Stage)	80,000 [23.4]	120,000 [35.2]	80,000 [23.4]	120,000 [35.2]
Heating Output Btu [kW] (1st Stage / 2nd Stage)	64,800 [19]	97,200 [28.5]	64,800 [19]	97,200 [28.5]
Temperature Rise Range °F [°C]	30-60 [16.7/33.3]	50-80 [27.8/44.4]	35-65 [19.4/36.1]	50-80 [27.8/44.4]
AFUE %	80	80	80	80
Steady State Efficiency (%)	81	81	81	81
No. Burners	4	6	4	6
No. Stages	1	1	1	1
Gas Connection Pipe Size in. [mm]	0.5 [12.7]	0.5 [12.7]	0.5 [12.7]	0.5 [12.7]
Compressor				
No./Type	1/Scroll	1/Scroll	1/Scroll	1/Scroll
Outdoor Sound Rating (dB)⁵				
	78	78	78	78
Outdoor Coil—Fin Type				
Tube Type	Louvered	Louvered	Louvered	Louvered
Tube Size in. [mm] OD	0.375 [9.5]	0.375 [9.5]	0.375 [9.5]	0.375 [9.5]
Face Area sq. ft. [sq. m]	11.04 [1.03]	11.04 [1.03]	11.04 [1.03]	11.04 [1.03]
Rows / FPI [FPcm]	1 / 18 [7]	1 / 18 [7]	1 / 18 [7]	1 / 18 [7]
Indoor Coil—Fin Type				
Tube Type	Louvered	Louvered	Louvered	Louvered
Tube Size in. [mm]	0.3125 [7.9]	0.3125 [7.9]	0.3125 [7.9]	0.3125 [7.9]
Face Area sq. ft. [sq. m]	5.17 [0.48]	5.17 [0.48]	5.17 [0.48]	5.17 [0.48]
Rows / FPI [FPcm]	3 / 13 [5]	3 / 13 [5]	3 / 13 [5]	3 / 13 [5]
Refrigerant Control	Capillary Tubes	Capillary Tubes	Capillary Tubes	Capillary Tubes
Drain Connection No./Size in. [mm]	1/1 [25.4]	1/1 [25.4]	1/1 [25.4]	1/1 [25.4]
Outdoor Fan—Type				
No. Used/Diameter in. [mm]	Propeller	Propeller	Propeller	Propeller
Drive Type/No. Speeds	1/24 [609.6]	1/24 [609.6]	1/24 [609.6]	1/24 [609.6]
CFM [L/s]	Direct/1	Direct/1	Direct/1	Direct/1
No. Motors/HP	3600 [1699]	3600 [1699]	3600 [1699]	3600 [1699]
Motor RPM	1 at 1/3 HP	1 at 1/3 HP	1 at 1/3 HP	1 at 1/3 HP
	1075	1075	1075	1075
Indoor Fan—Type				
No. Used/Diameter in. [mm]	FC Centrifugal	FC Centrifugal	FC Centrifugal	FC Centrifugal
Drive Type/No. Speeds	1/11x11 [279.4x279.4]	1/11x11 [279.4x279.4]	1/11x11 [279.4x279.4]	1/11x11 [279.4x279.4]
No. Motors	Direct/3	Direct/3	Belt/Variable	Belt/Variable
Motor HP	1	1	1	1
Motor RPM	1/2	1/2	1/2	1/2
Motor Frame Size	1725	1725	1725	1725
	48	48	56	56
Filter—Type				
Furnished	Disposable	Disposable	Disposable	Disposable
(No.) Size Recommended in. [mm]	Yes	Yes	Yes	Yes
	(1)1x16x25 [25x406x635]	(1)1x16x25 [25x406x635]	(1)1x16x25 [25x406x635]	(1)1x16x25 [25x406x635]
	(1)1x16x25 [25x406x635]	(1)1x16x25 [25x406x635]	(1)1x16x25 [25x406x635]	(1)1x16x25 [25x406x635]
Refrigerant Charge Oz. (Sys. 1/Sys. 2) [g]				
	72 [2041]	72 [2041]	72 [2041]	72 [2041]
Weights				
Net Weight lbs. [kg]	513 [233]	522 [237]	513 [233]	522 [237]
Ship Weight lbs. [kg]	520 [236]	529 [240]	520 [236]	529 [240]

See Page 37 for Notes.

[] Designates Metric Conversions



NOM. SIZES 3-7.5 TONS [10.6-26.4 kW] ASHRAE 90.1-1999 COMPLIANT MODELS

Model RKKA- Series	A036CM08E	A036CM12E	A036DK08E	A036DK12E
Cooling Performance¹				
Gross Cooling Capacity Btu [kW]	37,600 [11]	37,600 [11]	37,600 [11]	37,600 [11]
EER/SEER ²	9.4/10.2	9.4/10.2	9.4/10.2	9.4/10.2
Nominal CFM/ARI Rated CFM [L/s]	1200/1200 [566/566]	1200/1200 [566/566]	1200/1200 [566/566]	1200/1200 [566/566]
ARI Net Cooling Capacity Btu [kW]	36,000 [10.5]	36,000 [10.5]	36,000 [10.5]	36,000 [10.5]
Net Sensible Capacity Btu [kW]	26,500 [7.8]	26,500 [7.8]	26,500 [7.8]	26,500 [7.8]
Net Latent Capacity Btu [kW]	9500 [2.8]	9500 [2.8]	9500 [2.8]	9500 [2.8]
Net System Power kW	3.8	3.8	3.8	3.8
Heating Performance (Package Gas/Electric)⁴				
Heating Input Btu [kW] (1st Stage / 2nd Stage)	80,000 [23.4]	120,000 [35.2]	80,000 [23.4]	120,000 [35.2]
Heating Output Btu [kW] (1st Stage / 2nd Stage)	64,800 [19]	97,200 [28.5]	64,800 [19]	97,200 [28.5]
Temperature Rise Range °F [°C]	35-65 [19.4/36.1]	50-80 [27.8/44.4]	35-65 [19.4/36.1]	50-80 [27.8/44.4]
AFUE %	80	80	80	80
Steady State Efficiency (%)	81	81	81	81
No. Burners	4	6	4	6
No. Stages	1	1	1	1
Gas Connection Pipe Size in. [mm]	0.5 [12.7]	0.5 [12.7]	0.5 [12.7]	0.5 [12.7]
Compressor				
No./Type	1/Scroll	1/Scroll	1/Scroll	1/Scroll
Outdoor Sound Rating (dB)⁵				
	78	78	78	78
Outdoor Coil—Fin Type				
Tube Type	Louvered	Louvered	Louvered	Louvered
Tube Size in. [mm] OD	0.375 [9.5]	0.375 [9.5]	0.375 [9.5]	0.375 [9.5]
Face Area sq. ft. [sq. m]	11.04 [1.03]	11.04 [1.03]	11.04 [1.03]	11.04 [1.03]
Rows / FPI [FPcm]	1 / 18 [7]	1 / 18 [7]	1 / 18 [7]	1 / 18 [7]
Indoor Coil—Fin Type				
Tube Type	Louvered	Louvered	Louvered	Louvered
Tube Size in. [mm]	0.3125 [7.9]	0.3125 [7.9]	0.3125 [7.9]	0.3125 [7.9]
Face Area sq. ft. [sq. m]	5.17 [0.48]	5.17 [0.48]	5.17 [0.48]	5.17 [0.48]
Rows / FPI [FPcm]	3 / 13 [5]	3 / 13 [5]	3 / 13 [5]	3 / 13 [5]
Refrigerant Control	Capillary Tubes	Capillary Tubes	Capillary Tubes	Capillary Tubes
Drain Connection No./Size in. [mm]	1/1 [25.4]	1/1 [25.4]	1/1 [25.4]	1/1 [25.4]
Outdoor Fan—Type				
No. Used/Diameter in. [mm]	1/24 [609.6]	1/24 [609.6]	1/24 [609.6]	1/24 [609.6]
Drive Type/No. Speeds	Direct/1	Direct/1	Direct/1	Direct/1
CFM [L/s]	3600 [1699]	3600 [1699]	3600 [1699]	3600 [1699]
No. Motors/HP	1 at 1/3 HP	1 at 1/3 HP	1 at 1/3 HP	1 at 1/3 HP
Motor RPM	1075	1075	1075	1075
Indoor Fan—Type				
No. Used/Diameter in. [mm]	1/11x11 [279.4x279.4]	1/11x11 [279.4x279.4]	1/11x11 [279.4x279.4]	1/11x11 [279.4x279.4]
Drive Type/No. Speeds	Belt/Variable	Belt/Variable	Direct/3	Direct/3
No. Motors	1	1	1	1
Motor HP	1/2	1/2	1/2	1/2
Motor RPM	1725	1725	1725	1725
Motor Frame Size	56	56	48	48
Filter—Type				
Furnished	Disposable	Disposable	Disposable	Disposable
(No.) Size Recommended in. [mm]	(1)1x16x25 [25x406x635]	(1)1x16x25 [25x406x635]	(1)1x16x25 [25x406x635]	(1)1x16x25 [25x406x635]
	(1)1x16x25 [25x406x635]	(1)1x16x25 [25x406x635]	(1)1x16x25 [25x406x635]	(1)1x16x25 [25x406x635]
Refrigerant Charge Oz. (Sys. 1/Sys. 2) [g]				
	72 [2041]	72 [2041]	72 [2041]	72 [2041]
Weights				
Net Weight lbs. [kg]	513 [233]	513 [233]	513 [233]	522 [237]
Ship Weight lbs. [kg]	520 [236]	520 [236]	520 [236]	529 [240]

CONTINUED →

See Page 37 for Notes.

[] Designates Metric Conversions



NOM. SIZES 3-7.5 TONS [10.6-26.4 kW] ASHRAE 90.1-1999 COMPLIANT MODELS

Model RKKA- Series	A036DL08E	A036DL12E	A036DM08E	A036DM12E
Cooling Performance¹				
CONTINUED →				
Gross Cooling Capacity Btu [kW]	37,600 [11]	37,600 [11]	37,600 [11]	37,600 [11]
EER/SEER ²	9.4/10.2	9.4/10.2	9.4/10.2	9.4/10.2
Nominal CFM/ARI Rated CFM [L/s]	1200/1200 [566/566]	1200/1200 [566/566]	1200/1200 [566/566]	1200/1200 [566/566]
ARI Net Cooling Capacity Btu [kW]	36,000 [10.5]	36,000 [10.5]	36,000 [10.5]	36,000 [10.5]
Net Sensible Capacity Btu [kW]	26,500 [7.8]	26,500 [7.8]	26,500 [7.8]	26,500 [7.8]
Net Latent Capacity Btu [kW]	9500 [2.8]	9500 [2.8]	9500 [2.8]	9500 [2.8]
Net System Power kW	3.8	3.8	3.8	3.8
Heating Performance (Package Gas/Electric)⁴				
Heating Input Btu [kW] (1st Stage / 2nd Stage)	80,000 [23.4]	120,000 [35.2]	80,000 [23.4]	120,000 [35.2]
Heating Output Btu [kW] (1st Stage / 2nd Stage)	64,800 [19]	97,200 [28.5]	64,800 [19]	97,200 [28.5]
Temperature Rise Range °F [°C]	35-65 [19.4/36.1]	50-80 [27.8/44.4]	35-65 [19.4/36.1]	50-80 [27.8/44.4]
AFUE %	80	80	80	80
Steady State Efficiency (%)	81	81	81	81
No. Burners	4	6	4	6
No. Stages	1	1	1	1
Gas Connection Pipe Size in. [mm]	0.5 [12.7]	0.5 [12.7]	0.5 [12.7]	0.5 [12.7]
Compressor				
No./Type	1/Scroll	1/Scroll	1/Scroll	1/Scroll
Outdoor Sound Rating (dB)⁵				
	78	78	78	78
Outdoor Coil—Fin Type				
Tube Type	Louvered	Louvered	Louvered	Louvered
Tube Size in. [mm] OD	0.375 [9.5]	0.375 [9.5]	0.375 [9.5]	0.375 [9.5]
Face Area sq. ft. [sq. m]	11.04 [1.03]	11.04 [1.03]	11.04 [1.03]	11.04 [1.03]
Rows / FPI [FPcm]	1 / 18 [7]	1 / 18 [7]	1 / 18 [7]	1 / 18 [7]
Indoor Coil—Fin Type				
Tube Type	Louvered	Louvered	Louvered	Louvered
Tube Size in. [mm]	0.3125 [7.9]	0.3125 [7.9]	0.3125 [7.9]	0.3125 [7.9]
Face Area sq. ft. [sq. m]	5.17 [0.48]	5.17 [0.48]	5.17 [0.48]	5.17 [0.48]
Rows / FPI [FPcm]	3 / 13 [5]	3 / 13 [5]	3 / 13 [5]	3 / 13 [5]
Refrigerant Control	Capillary Tubes	Capillary Tubes	Capillary Tubes	Capillary Tubes
Drain Connection No./Size in. [mm]	1/1 [25.4]	1/1 [25.4]	1/1 [25.4]	1/1 [25.4]
Outdoor Fan—Type				
No. Used/Diameter in. [mm]	Propeller	Propeller	Propeller	Propeller
Drive Type/No. Speeds	1/24 [609.6]	1/24 [609.6]	1/24 [609.6]	1/24 [609.6]
CFM [L/s]	Direct/1	Direct/1	Direct/1	Direct/1
No. Motors/HP	3600 [1699]	3600 [1699]	3600 [1699]	3600 [1699]
Motor RPM	1 at 1/3 HP	1 at 1/3 HP	1 at 1/3 HP	1 at 1/3 HP
	1075	1075	1075	1075
Indoor Fan—Type				
No. Used/Diameter in. [mm]	FC Centrifugal	FC Centrifugal	FC Centrifugal	FC Centrifugal
Drive Type/No. Speeds	1/11x11 [279.4x279.4]	1/11x11 [279.4x279.4]	1/11x11 [279.4x279.4]	1/11x11 [279.4x279.4]
No. Motors	Belt/Variable	Belt/Variable	Belt/Variable	Belt/Variable
Motor HP	1	1	1	1
Motor RPM	1/2	1/2	1/2	1/2
Motor Frame Size	1725	1725	1725	1725
	56	56	56	56
Filter—Type				
Furnished	Disposable	Disposable	Disposable	Disposable
(No.) Size Recommended in. [mm]	Yes	Yes	Yes	Yes
	(1)1x16x25 [25x406x635]	(1)1x16x25 [25x406x635]	(1)1x16x25 [25x406x635]	(1)1x16x25 [25x406x635]
	(1)1x16x25 [25x406x635]	(1)1x16x25 [25x406x635]	(1)1x16x25 [25x406x635]	(1)1x16x25 [25x406x635]
Refrigerant Charge Oz. (Sys. 1/Sys. 2) [g]				
	72 [2041]	72 [2041]	72 [2041]	72 [2041]
Weights				
Net Weight lbs. [kg]	513 [233]	522 [237]	513 [233]	513 [233]
Ship Weight lbs. [kg]	520 [236]	529 [240]	520 [236]	520 [236]

See Page 37 for Notes.

[] Designates Metric Conversions



NOM. SIZES 3-7.5 TONS [10.6-26.4 kW] ASHRAE 90.1-1999 COMPLIANT MODELS

Model RKKA- Series	A036YL08E	A036YL12E	A036YM08E	A036YM12E
Cooling Performance¹				CONTINUED →
Gross Cooling Capacity Btu [kW]	37,600 [11]	37,600 [11]	37,600 [11]	37,600 [11]
EER/SEER ²	9.4/10.2	9.4/10.2	9.4/10.2	9.4/10.2
Nominal CFM/ARI Rated CFM [L/s]	1200/1200 [566/566]	1200/1200 [566/566]	1200/1200 [566/566]	1200/1200 [566/566]
ARI Net Cooling Capacity Btu [kW]	36,000 [10.5]	36,000 [10.5]	36,000 [10.5]	36,000 [10.5]
Net Sensible Capacity Btu [kW]	26,500 [7.8]	26,500 [7.8]	26,500 [7.8]	26,500 [7.8]
Net Latent Capacity Btu [kW]	9500 [2.8]	9500 [2.8]	9500 [2.8]	9500 [2.8]
Net System Power kW	3.8	3.8	3.8	3.8
Heating Performance (Package Gas/Electric)⁴				
Heating Input Btu [kW]	80,000 [23.4]	120,000 [35.2]	80,000 [23.4]	120,000 [35.2]
Heating Output Btu [kW]	64,800 [19]	97,200 [28.5]	64,800 [19]	97,200 [28.5]
Temperature Rise Range °F [°C]	35-65 [19.4/36.1]	50-80 [27.8/44.4]	35-65 [19.4/36.1]	50-80 [27.8/44.4]
AFUE %	80	80	80	80
Steady State Efficiency (%)	81	81	81	81
No. Burners	4	6	4	6
No. Stages	1	1	1	1
Gas Connection Pipe Size in. [mm]	0.5 [12.7]	0.5 [12.7]	0.5 [12.7]	0.5 [12.7]
Compressor				
No./Type	1/Scroll	1/Scroll	1/Scroll	1/Scroll
Outdoor Sound Rating (dB)⁵				
	78	78	78	78
Outdoor Coil—Fin Type				
Tube Type	Louvered	Louvered	Louvered	Louvered
Tube Size in. [mm] OD	0.375 [9.5]	0.375 [9.5]	0.375 [9.5]	0.375 [9.5]
Face Area sq. ft. [sq. m]	11.04 [1.03]	11.04 [1.03]	11.04 [1.03]	11.04 [1.03]
Rows / FPI [FPcm]	1 / 18 [7]	1 / 18 [7]	1 / 18 [7]	1 / 18 [7]
Indoor Coil—Fin Type				
Tube Type	Louvered	Louvered	Louvered	Louvered
Tube Size in. [mm]	0.3125 [7.9]	0.3125 [7.9]	0.3125 [7.9]	0.3125 [7.9]
Face Area sq. ft. [sq. m]	5.17 [0.48]	5.17 [0.48]	5.17 [0.48]	5.17 [0.48]
Rows / FPI [FPcm]	3 / 13 [5]	3 / 13 [5]	3 / 13 [5]	3 / 13 [5]
Refrigerant Control	Capillary Tubes	Capillary Tubes	Capillary Tubes	Capillary Tubes
Drain Connection No./Size in. [mm]	1/1 [25.4]	1/1 [25.4]	1/1 [25.4]	1/1 [25.4]
Outdoor Fan—Type				
No. Used/Diameter in. [mm]	Propeller 1/24 [609.6]	Propeller 1/24 [609.6]	Propeller 1/24 [609.6]	Propeller 1/24 [609.6]
Drive Type/No. Speeds	Direct/1	Direct/1	Direct/1	Direct/1
CFM [L/s]	3600 [1699]	3600 [1699]	3600 [1699]	3600 [1699]
No. Motors/HP	1 at 1/3 HP	1 at 1/3 HP	1 at 1/3 HP	1 at 1/3 HP
Motor RPM	1075	1075	1075	1075
Indoor Fan—Type				
No. Used/Diameter in. [mm]	FC Centrifugal 1/11x11 [279.4x279.4]	FC Centrifugal 1/11x11 [279.4x279.4]	FC Centrifugal 1/11x11 [279.4x279.4]	FC Centrifugal 1/11x11 [279.4x279.4]
Drive Type/No. Speeds	Belt/Variable	Belt/Variable	Belt/Variable	Belt/Variable
No. Motors	1	1	1	1
Motor HP	1/2	1/2	1/2	1/2
Motor RPM	1725	1725	1725	1725
Motor Frame Size	56	56	56	56
Filter—Type				
Furnished	Disposable Yes	Disposable Yes	Disposable Yes	Disposable Yes
(No.) Size Recommended in. [mm]	(1)1x16x25 [25x406x635] (1)1x16x25 [25x406x635]	(1)1x16x25 [25x406x635] (1)1x16x25 [25x406x635]	(1)1x16x25 [25x406x635] (1)1x16x25 [25x406x635]	(1)1x16x25 [25x406x635] (1)1x16x25 [25x406x635]
Refrigerant Charge Oz. [g]				
	72 [2041]	72 [2041]	72 [2041]	72 [2041]
Weights				
Net Weight lbs. [kg]	513 [233]	522 [237]	513 [233]	513 [233]
Ship Weight lbs. [kg]	520 [236]	529 [240]	520 [236]	520 [236]

See Page 37 for Notes.

[] Designates Metric Conversions



NOM. SIZES 3-7.5 TONS [10.6-26.4 kW] ASHRAE 90.1-1999 COMPLIANT MODELS

Model RKKA- Series	A042CK08E	A042CK12E	A042CL08E	A042CL12E
Cooling Performance¹				
	CONTINUED →			
Gross Cooling Capacity Btu [kW]	44,000 [12.9]	44,000 [12.9]	44,000 [12.9]	44,000 [12.9]
EER/SEER ²	9.05/10	9.05/10	9.05/10	9.05/10
Nominal CFM/ARI Rated CFM [L/s]	1400/1400 [661/661]	1400/1400 [661/661]	1400/1400 [661/661]	1400/1400 [661/661]
ARI Net Cooling Capacity Btu [kW]	42,000 [12.3]	42,000 [12.3]	42,000 [12.3]	42,000 [12.3]
Net Sensible Capacity Btu [kW]	32,000 [9.4]	32,000 [9.4]	32,000 [9.4]	32,000 [9.4]
Net Latent Capacity Btu [kW]	10,000 [2.9]	10,000 [2.9]	10,000 [2.9]	10,000 [2.9]
Net System Power kW	4.6	4.6	4.6	4.6
Heating Performance (Package Gas/Electric)⁴				
Heating Input Btu [kW]	80,000 [23.4]	120,000 [35.2]	80,000 [23.4]	120,000 [35.2]
Heating Output Btu [kW]	64,800 [19]	97,200 [28.5]	64,800 [19]	97,200 [28.5]
Temperature Rise Range °F [°C]	30-60 [16.7/33.3]	50-80 [27.8/44.4]	30-60 [16.7/33.3]	50-80 [27.8/44.4]
AFUE %	80	80	80	80
Steady State Efficiency (%)	81	81	81	81
No. Burners	4	6	4	6
No. Stages	1	1	1	1
Gas Connection Pipe Size in. [mm]	0.5 [12.7]	0.5 [12.7]	0.5 [12.7]	0.5 [12.7]
Compressor				
No./Type	1/Scroll	1/Scroll	1/Scroll	1/Scroll
Outdoor Sound Rating (dB)⁵				
	78	78	78	78
Outdoor Coil—Fin Type				
Tube Type	Louvered	Louvered	Louvered	Louvered
Tube Size in. [mm] OD	Smooth	Smooth	Smooth	Smooth
Face Area sq. ft. [sq. m]	0.375 [9.5]	0.375 [9.5]	0.375 [9.5]	0.375 [9.5]
Rows / FPI [FPcm]	11.04 [1.03]	11.04 [1.03]	11.04 [1.03]	11.04 [1.03]
Rows / FPI [FPcm]	1 / 18 [7]	1 / 18 [7]	1 / 18 [7]	1 / 18 [7]
Indoor Coil—Fin Type				
Tube Type	Louvered	Louvered	Louvered	Louvered
Tube Type	Smooth	Smooth	Smooth	Smooth
Tube Size in. [mm]	0.3125 [7.9]	0.3125 [7.9]	0.3125 [7.9]	0.3125 [7.9]
Face Area sq. ft. [sq. m]	5.17 [0.48]	5.17 [0.48]	5.17 [0.48]	5.17 [0.48]
Rows / FPI [FPcm]	4 / 13 [5]	4 / 13 [5]	4 / 13 [5]	4 / 13 [5]
Refrigerant Control	Capillary Tubes	Capillary Tubes	Capillary Tubes	Capillary Tubes
Drain Connection No./Size in. [mm]	1/1 [25.4]	1/1 [25.4]	1/1 [25.4]	1/1 [25.4]
Outdoor Fan—Type				
Propeller	Propeller	Propeller	Propeller	Propeller
No. Used/Diameter in. [mm]	1/24 [609.6]	1/24 [609.6]	1/24 [609.6]	1/24 [609.6]
Drive Type/No. Speeds	Direct/1	Direct/1	Direct/1	Direct/1
CFM [L/s]	3600 [1699]	3600 [1699]	3600 [1699]	3600 [1699]
No. Motors/HP	1 at 1/3 HP	1 at 1/3 HP	1 at 1/3 HP	1 at 1/3 HP
Motor RPM	1075	1075	1075	1075
Indoor Fan—Type				
FC Centrifugal	FC Centrifugal	FC Centrifugal	FC Centrifugal	FC Centrifugal
No. Used/Diameter in. [mm]	1/11x11 [279.4x279.4]	1/11x11 [279.4x279.4]	1/11x11 [279.4x279.4]	1/11x11 [279.4x279.4]
Drive Type/No. Speeds	Direct/3	Direct/3	Belt/Variable	Belt/Variable
No. Motors	1	1	1	1
Motor HP	1/2	1/2	1/2	1/2
Motor RPM	1725	1725	1725	1725
Motor Frame Size	48	48	56	56
Filter—Type				
Disposable	Disposable	Disposable	Disposable	Disposable
Furnished	Yes	Yes	Yes	Yes
(No.) Size Recommended in. [mm]	(1)1x16x25 [25x406x635]	(1)1x16x25 [25x406x635]	(1)1x16x25 [25x406x635]	(1)1x16x25 [25x406x635]
	(1)1x16x25 [25x406x635]	(1)1x16x25 [25x406x635]	(1)1x16x25 [25x406x635]	(1)1x16x25 [25x406x635]
Refrigerant Charge Oz. [g]				
	77 [2183]	77 [2183]	77 [2183]	77 [2183]
Weights				
Net Weight lbs. [kg]	529 [240]	538 [244]	529 [240]	538 [244]
Ship Weight lbs. [kg]	536 [243]	545 [247]	536 [243]	545 [247]

See Page 37 for Notes.

[] Designates Metric Conversions



NOM. SIZES 3-7.5 TONS [10.6-26.4 kW] ASHRAE 90.1-1999 COMPLIANT MODELS

Model RKKA- Series	A042CM08E	A042CM12E	A042DK08E	A042DK12E
Cooling Performance¹				CONTINUED →
Gross Cooling Capacity Btu [kW]	44,000 [12.9]	44,000 [12.9]	44,000 [12.9]	44,000 [12.9]
EER/SEER ²	9.05/10	9.05/10	9.05/10	9.05/10
Nominal CFM/ARI Rated CFM [L/s]	1400/1400 [661/661]	1400/1400 [661/661]	1400/1400 [661/661]	1400/1400 [661/661]
ARI Net Cooling Capacity Btu [kW]	42,000 [12.3]	42,000 [12.3]	42,000 [12.3]	42,000 [12.3]
Net Sensible Capacity Btu [kW]	32,000 [9.4]	32,000 [9.4]	32,000 [9.4]	32,000 [9.4]
Net Latent Capacity Btu [kW]	10,000 [2.9]	10,000 [2.9]	10,000 [2.9]	10,000 [2.9]
Net System Power kW	4.6	4.6	4.6	4.6
Heating Performance (Package Gas/Electric)⁴				
Heating Input Btu [kW]	80,000 [23.4]	120,000 [35.2]	80,000 [23.4]	120,000 [35.2]
Heating Output Btu [kW]	64,800 [19]	97,200 [28.5]	64,800 [19]	97,200 [28.5]
Temperature Rise Range °F [°C]	30-60 [16.7/33.3]	50-80 [27.8/44.4]	30-60 [16.7/33.3]	50-80 [27.8/44.4]
AFUE %	80	80	80	80
Steady State Efficiency (%)	81	81	81	81
No. Burners	4	6	4	6
No. Stages	1	1	1	1
Gas Connection Pipe Size in. [mm]	0.5 [12.7]	0.5 [12.7]	0.5 [12.7]	0.5 [12.7]
Compressor				
No./Type	1/Scroll	1/Scroll	1/Scroll	1/Scroll
Outdoor Sound Rating (dB)⁵				
	78	78	78	78
Outdoor Coil—Fin Type				
Tube Type	Louvered	Louvered	Louvered	Louvered
Tube Size in. [mm] OD	0.375 [9.5]	0.375 [9.5]	0.375 [9.5]	0.375 [9.5]
Face Area sq. ft. [sq. m]	11.04 [1.03]	11.04 [1.03]	11.04 [1.03]	11.04 [1.03]
Rows / FPI [FPcm]	1 / 18 [7]	1 / 18 [7]	1 / 18 [7]	1 / 18 [7]
Indoor Coil—Fin Type				
Tube Type	Louvered	Louvered	Louvered	Louvered
Tube Size in. [mm]	0.3125 [7.9]	0.3125 [7.9]	0.3125 [7.9]	0.3125 [7.9]
Face Area sq. ft. [sq. m]	5.17 [0.48]	5.17 [0.48]	5.17 [0.48]	5.17 [0.48]
Rows / FPI [FPcm]	4 / 13 [5]	4 / 13 [5]	4 / 13 [5]	4 / 13 [5]
Refrigerant Control	Capillary Tubes	Capillary Tubes	Capillary Tubes	Capillary Tubes
Drain Connection No./Size in. [mm]	1/1 [25.4]	1/1 [25.4]	1/1 [25.4]	1/1 [25.4]
Outdoor Fan—Type				
No. Used/Diameter in. [mm]	1/24 [609.6]	1/24 [609.6]	1/24 [609.6]	1/24 [609.6]
Drive Type/No. Speeds	Direct/1	Direct/1	Direct/1	Direct/1
CFM [L/s]	3600 [1699]	3600 [1699]	3600 [1699]	3600 [1699]
No. Motors/HP	1 at 1/3 HP	1 at 1/3 HP	1 at 1/3 HP	1 at 1/3 HP
Motor RPM	1075	1075	1075	1075
Indoor Fan—Type				
No. Used/Diameter in. [mm]	FC Centrifugal 1/11x11 [279.4x279.4]	FC Centrifugal 1/11x11 [279.4x279.4]	FC Centrifugal 1/11x11 [279.4x279.4]	FC Centrifugal 1/11x11 [279.4x279.4]
Drive Type/No. Speeds	Belt/Variable	Belt/Variable	Direct/3	Direct/3
No. Motors	1	1	1	1
Motor HP	1/2	1/2	1/2	1/2
Motor RPM	1725	1725	1725	1725
Motor Frame Size	56	56	48	48
Filter—Type				
Furnished	Disposable Yes	Disposable Yes	Disposable Yes	Disposable Yes
(No.) Size Recommended in. [mm]	(1)1x16x25 [25x406x635] (1)1x16x25 [25x406x635]	(1)1x16x25 [25x406x635] (1)1x16x25 [25x406x635]	(1)1x16x25 [25x406x635] (1)1x16x25 [25x406x635]	(1)1x16x25 [25x406x635] (1)1x16x25 [25x406x635]
Refrigerant Charge Oz. [g]				
	77 [2183]	77 [2183]	77 [2183]	77 [2183]
Weights				
Net Weight lbs. [kg]	529 [240]	529 [240]	529 [240]	538 [244]
Ship Weight lbs. [kg]	536 [243]	536 [243]	536 [243]	545 [247]

See Page 37 for Notes.

[] Designates Metric Conversions



NOM. SIZES 3-7.5 TONS [10.6-26.4 kW] ASHRAE 90.1-1999 COMPLIANT MODELS

Model RKKA- Series	A042DL08E	A042DL12E	A042DM08E	A042DM12E
Cooling Performance¹				
	CONTINUED →			
Gross Cooling Capacity Btu [kW]	44,000 [12.9]	44,000 [12.9]	44,000 [12.9]	44,000 [12.9]
EER/SEER ²	9.05/10	9.05/10	9.05/10	9.05/10
Nominal CFM/ARI Rated CFM [L/s]	1400/1400 [661/661]	1400/1400 [661/661]	1400/1400 [661/661]	1400/1400 [661/661]
ARI Net Cooling Capacity Btu [kW]	42,000 [12.3]	42,000 [12.3]	42,000 [12.3]	42,000 [12.3]
Net Sensible Capacity Btu [kW]	32,000 [9.4]	32,000 [9.4]	32,000 [9.4]	32,000 [9.4]
Net Latent Capacity Btu [kW]	10,000 [2.9]	10,000 [2.9]	10,000 [2.9]	10,000 [2.9]
Net System Power kW	4.6	4.6	4.6	4.6
Heating Performance (Package Gas/Electric)⁴				
Heating Input Btu [kW]	80,000 [23.4]	120,000 [35.2]	80,000 [23.4]	120,000 [35.2]
Heating Output Btu [kW]	64,800 [19]	97,200 [28.5]	64,800 [19]	97,200 [28.5]
Temperature Rise Range °F [°C]	30-60 [16.7/33.3]	50-80 [27.8/44.4]	30-60 [16.7/33.3]	50-80 [27.8/44.4]
AFUE %	80	80	80	80
Steady State Efficiency (%)	81	81	81	81
No. Burners	4	6	4	6
No. Stages	1	1	1	1
Gas Connection Pipe Size in. [mm]	0.5 [12.7]	0.5 [12.7]	0.5 [12.7]	0.5 [12.7]
Compressor				
No./Type	1/Scroll	1/Scroll	1/Scroll	1/Scroll
Outdoor Sound Rating (dB)⁵				
	78	78	78	78
Outdoor Coil—Fin Type				
Tube Type	Louvered	Louvered	Louvered	Louvered
Tube Size in. [mm] OD	0.375 [9.5]	0.375 [9.5]	0.375 [9.5]	0.375 [9.5]
Face Area sq. ft. [sq. m]	11.04 [1.03]	11.04 [1.03]	11.04 [1.03]	11.04 [1.03]
Rows / FPI [FPcm]	1 / 18 [7]	1 / 18 [7]	1 / 18 [7]	1 / 18 [7]
Indoor Coil—Fin Type				
Tube Type	Louvered	Louvered	Louvered	Louvered
Tube Size in. [mm]	0.3125 [7.9]	0.3125 [7.9]	0.3125 [7.9]	0.3125 [7.9]
Face Area sq. ft. [sq. m]	5.17 [0.48]	5.17 [0.48]	5.17 [0.48]	5.17 [0.48]
Rows / FPI [FPcm]	4 / 13 [5]	4 / 13 [5]	4 / 13 [5]	4 / 13 [5]
Refrigerant Control	Capillary Tubes	Capillary Tubes	Capillary Tubes	Capillary Tubes
Drain Connection No./Size in. [mm]	1/1 [25.4]	1/1 [25.4]	1/1 [25.4]	1/1 [25.4]
Outdoor Fan—Type				
No. Used/Diameter in. [mm]	Propeller	Propeller	Propeller	Propeller
Drive Type/No. Speeds	1/24 [609.6]	1/24 [609.6]	1/24 [609.6]	1/24 [609.6]
CFM [L/s]	Direct/1	Direct/1	Direct/1	Direct/1
No. Motors/HP	3600 [1699]	3600 [1699]	3600 [1699]	3600 [1699]
Motor RPM	1 at 1/3 HP	1 at 1/3 HP	1 at 1/3 HP	1 at 1/3 HP
	1075	1075	1075	1075
Indoor Fan—Type				
No. Used/Diameter in. [mm]	FC Centrifugal	FC Centrifugal	FC Centrifugal	FC Centrifugal
Drive Type/No. Speeds	1/11x11 [279.4x279.4]	1/11x11 [279.4x279.4]	1/11x11 [279.4x279.4]	1/11x11 [279.4x279.4]
No. Motors	Belt/Variable	Belt/Variable	Belt/Variable	Belt/Variable
Motor HP	1	1	1	1
Motor RPM	1/2	1/2	1/2	1/2
Motor Frame Size	1725	1725	1725	1725
	56	56	56	56
Filter—Type				
Furnished	Disposable	Disposable	Disposable	Disposable
(No.) Size Recommended in. [mm]	Yes	Yes	Yes	Yes
	(1)1x16x25 [25x406x635]	(1)1x16x25 [25x406x635]	(1)1x16x25 [25x406x635]	(1)1x16x25 [25x406x635]
	(1)1x16x25 [25x406x635]	(1)1x16x25 [25x406x635]	(1)1x16x25 [25x406x635]	(1)1x16x25 [25x406x635]
Refrigerant Charge Oz. [g]				
	77 [2183]	77 [2183]	77 [2183]	77 [2183]
Weights				
Net Weight lbs. [kg]	529 [240]	538 [244]	529 [240]	529 [240]
Ship Weight lbs. [kg]	536 [243]	545 [247]	536 [243]	536 [243]

See Page 37 for Notes.

[] Designates Metric Conversions



NOM. SIZES 3-7.5 TONS [10.6-26.4 kW] ASHRAE 90.1-1999 COMPLIANT MODELS

Model RKKA- Series	A042YL08E	A042YL12E	A042YM08E	A042YM12E
Cooling Performance¹				
Gross Cooling Capacity Btu [kW]	44,000 [12.9]	44,000 [12.9]	44,000 [12.9]	44,000 [12.9]
EER/SEER ²	9.05/10	9.05/10	9.05/10	9.05/10
Nominal CFM/ARI Rated CFM [L/s]	1400/1400 [661/661]	1400/1400 [661/661]	1400/1400 [661/661]	1400/1400 [661/661]
ARI Net Cooling Capacity Btu [kW]	42,000 [12.3]	42,000 [12.3]	42,000 [12.3]	42,000 [12.3]
Net Sensible Capacity Btu [kW]	32,000 [9.4]	32,000 [9.4]	32,000 [9.4]	32,000 [9.4]
Net Latent Capacity Btu [kW]	10,000 [2.9]	10,000 [2.9]	10,000 [2.9]	10,000 [2.9]
Net System Power kW	4.6	4.6	4.6	4.6
Heating Performance (Package Gas/Electric)⁴				
Heating Input Btu [kW]	80,000 [23.4]	120,000 [35.2]	80,000 [23.4]	120,000 [35.2]
Heating Output Btu [kW]	64,800 [19]	97,200 [28.5]	64,800 [19]	97,200 [28.5]
Temperature Rise Range °F [°C]	30-60 [16.7/33.3]	50-80 [27.8/44.4]	30-60 [16.7/33.3]	50-80 [27.8/44.4]
AFUE %	80	80	80	80
Steady State Efficiency (%)	81	81	81	81
No. Burners	4	6	4	6
No. Stages	1	1	1	1
Gas Connection Pipe Size in. [mm]	0.5 [12.7]	0.5 [12.7]	0.5 [12.7]	0.5 [12.7]
Compressor				
No./Type	1/Scroll	1/Scroll	1/Scroll	1/Scroll
Outdoor Sound Rating (dB)⁵				
	78	78	78	78
Outdoor Coil—Fin Type				
Tube Type	Louvered	Louvered	Louvered	Louvered
Tube Size in. [mm] OD	0.375 [9.5]	0.375 [9.5]	0.375 [9.5]	0.375 [9.5]
Face Area sq. ft. [sq. m]	11.04 [1.03]	11.04 [1.03]	11.04 [1.03]	11.04 [1.03]
Rows / FPI [FPcm]	1 / 18 [7]	1 / 18 [7]	1 / 18 [7]	1 / 18 [7]
Indoor Coil—Fin Type				
Tube Type	Louvered	Louvered	Louvered	Louvered
Tube Size in. [mm]	0.3125 [7.9]	0.3125 [7.9]	0.3125 [7.9]	0.3125 [7.9]
Face Area sq. ft. [sq. m]	5.17 [0.48]	5.17 [0.48]	5.17 [0.48]	5.17 [0.48]
Rows / FPI [FPcm]	4 / 13 [5]	4 / 13 [5]	4 / 13 [5]	4 / 13 [5]
Refrigerant Control	Capillary Tubes	Capillary Tubes	Capillary Tubes	Capillary Tubes
Drain Connection No./Size in. [mm]	1/1 [25.4]	1/1 [25.4]	1/1 [25.4]	1/1 [25.4]
Outdoor Fan—Type				
No. Used/Diameter in. [mm]	1/24 [609.6]	1/24 [609.6]	1/24 [609.6]	1/24 [609.6]
Drive Type/No. Speeds	Direct/1	Direct/1	Direct/1	Direct/1
CFM [L/s]	3600 [1699]	3600 [1699]	3600 [1699]	3600 [1699]
No. Motors/HP	1 at 1/3 HP	1 at 1/3 HP	1 at 1/3 HP	1 at 1/3 HP
Motor RPM	1075	1075	1075	1075
Indoor Fan—Type				
No. Used/Diameter in. [mm]	FC Centrifugal 1/11x11 [279.4x279.4]	FC Centrifugal 1/11x11 [279.4x279.4]	FC Centrifugal 1/11x11 [279.4x279.4]	FC Centrifugal 1/11x11 [279.4x279.4]
Drive Type/No. Speeds	Belt/Variable	Belt/Variable	Belt/Variable	Belt/Variable
No. Motors	1	1	1	1
Motor HP	1/2	1/2	1/2	1/2
Motor RPM	1725	1725	1725	1725
Motor Frame Size	56	56	56	56
Filter—Type				
Furnished	Disposable	Disposable	Disposable	Disposable
(No.) Size Recommended in. [mm]	Yes (1)1x16x25 [25x406x635]	Yes (1)1x16x25 [25x406x635]	Yes (1)1x16x25 [25x406x635]	Yes (1)1x16x25 [25x406x635]
	(1)1x16x25 [25x406x635]	(1)1x16x25 [25x406x635]	(1)1x16x25 [25x406x635]	(1)1x16x25 [25x406x635]
Refrigerant Charge Oz. [g]				
	77 [2183]	77 [2183]	77 [2183]	77 [2183]
Weights				
Net Weight lbs. [kg]	529 [240]	538 [244]	529 [240]	529 [240]
Ship Weight lbs. [kg]	536 [243]	545 [247]	536 [243]	536 [243]

CONTINUED →

See Page 37 for Notes.

[] Designates Metric Conversions



NOM. SIZES 3-7.5 TONS [10.6-26.4 kW] ASHRAE 90.1-1999 COMPLIANT MODELS

Model RKKA- Series	A048CK08E	A048CK10E	A048CK13E	A048CL08E
Cooling Performance¹				
CONTINUED →				
Gross Cooling Capacity Btu [kW]	50,000 [14.6]	50,000 [14.6]	50,000 [14.6]	50,000 [14.6]
EER/SEER ²	9.8/10.4	9.8/10.4	9.8/10.4	9.8/10.4
Nominal CFM/ARI Rated CFM [L/s]	1600/1600 [755/755]	1600/1600 [755/755]	1600/1600 [755/755]	1600/1600 [755/755]
ARI Net Cooling Capacity Btu [kW]	48,000 [14.1]	48,000 [14.1]	48,000 [14.1]	48,000 [14.1]
Net Sensible Capacity Btu [kW]	35,500 [10.4]	35,500 [10.4]	35,500 [10.4]	35,500 [10.4]
Net Latent Capacity Btu [kW]	12,500 [3.7]	12,500 [3.7]	12,500 [3.7]	12,500 [3.7]
Net System Power kW	4.9	4.9	4.9	4.9
Heating Performance (Package Gas/Electric)⁴				
Heating Input Btu [kW]	80,000 [23.4]	100,000 [29.3]	135,000 [39.6]	80,000 [23.4]
Heating Output Btu [kW]	64,800 [19]	81,000 [23.7]	109,400 [32.1]	64,800 [19]
Temperature Rise Range °F [°C]	30-60 [16.7/33.3]	40-70 [22.2/38.9]	50-80 [27.8/44.4]	30-60 [16.7/33.3]
AFUE %	80	80	80	80
Steady State Efficiency (%)	81	81	81	81
No. Burners	4	5	6	4
No. Stages	1	1	1	1
Gas Connection Pipe Size in. [mm]	0.5 [12.7]	0.5 [12.7]	0.5 [12.7]	0.5 [12.7]
Compressor				
No./Type	1/Scroll	1/Scroll	1/Scroll	1/Scroll
Outdoor Sound Rating (dB)⁵				
	78	78	78	78
Outdoor Coil—Fin Type				
Tube Type	Louvered	Louvered	Louvered	Louvered
Tube Size in. [mm] OD	0.375 [9.5]	0.375 [9.5]	0.375 [9.5]	0.375 [9.5]
Face Area sq. ft. [sq. m]	16.91 [1.57]	16.91 [1.57]	16.91 [1.57]	16.91 [1.57]
Rows / FPI [FPcm]	1 / 18 [7]	1 / 18 [7]	1 / 18 [7]	1 / 18 [7]
Indoor Coil—Fin Type				
Tube Type	Louvered	Louvered	Louvered	Louvered
Tube Size in. [mm]	0.3125 [7.9]	0.3125 [7.9]	0.3125 [7.9]	0.3125 [7.9]
Face Area sq. ft. [sq. m]	5.17 [0.48]	5.17 [0.48]	5.17 [0.48]	5.17 [0.48]
Rows / FPI [FPcm]	4 / 13 [5]	4 / 13 [5]	4 / 13 [5]	4 / 13 [5]
Refrigerant Control	Capillary Tubes	Capillary Tubes	Capillary Tubes	Capillary Tubes
Drain Connection No./Size in. [mm]	1/1 [25.4]	1/1 [25.4]	1/1 [25.4]	1/1 [25.4]
Outdoor Fan—Type				
No. Used/Diameter in. [mm]	Propeller	Propeller	Propeller	Propeller
Drive Type/No. Speeds	1/24 [609.6]	1/24 [609.6]	1/24 [609.6]	1/24 [609.6]
CFM [L/s]	Direct/1	Direct/1	Direct/1	Direct/1
No. Motors/HP	4000 [1888]	4000 [1888]	4000 [1888]	4000 [1888]
Motor RPM	1 at 1/3 HP	1 at 1/3 HP	1 at 1/3 HP	1 at 1/3 HP
	1075	1075	1075	1075
Indoor Fan—Type				
No. Used/Diameter in. [mm]	FC Centrifugal	FC Centrifugal	FC Centrifugal	FC Centrifugal
Drive Type/No. Speeds	1/11x11 [279.4x279.4]	1/11x11 [279.4x279.4]	1/11x11 [279.4x279.4]	1/11x11 [279.4x279.4]
No. Motors	Direct/3	Direct/3	Direct/3	Belt/Variable
Motor HP	1	1	1	1
Motor RPM	1/2	1/2	1/2	1/2
Motor Frame Size	1725	1725	1725	1725
	48	48	48	56
Filter—Type				
Furnished	Disposable	Disposable	Disposable	Disposable
(No.) Size Recommended in. [mm]	Yes	Yes	Yes	Yes
	(1)1x16x25 [25x406x635]	(1)1x16x25 [25x406x635]	(1)1x16x25 [25x406x635]	(1)1x16x25 [25x406x635]
	(1)1x16x25 [25x406x635]	(1)1x16x25 [25x406x635]	(1)1x16x25 [25x406x635]	(1)1x16x25 [25x406x635]
Refrigerant Charge Oz. [g]				
	106 [3005]	106 [3005]	106 [3005]	106 [3005]
Weights				
Net Weight lbs. [kg]	573 [260]	573 [260]	578 [262]	573 [260]
Ship Weight lbs. [kg]	580 [263]	580 [263]	585 [265]	580 [263]

See Page 37 for Notes.

[] Designates Metric Conversions



NOM. SIZES 3-7.5 TONS [10.6-26.4 kW] ASHRAE 90.1-1999 COMPLIANT MODELS

Model RKKA- Series	A048CL10E	A048CL13E	A048CM08E	A048CM10E
Cooling Performance¹				CONTINUED →
Gross Cooling Capacity Btu [kW]	50,000 [14.6]	50,000 [14.6]	50,000 [14.6]	50,000 [14.6]
EER/SEER ²	9.8/10.4	9.8/10.4	9.8/10.4	9.8/10.4
Nominal CFM/ARI Rated CFM [L/s]	1600/1600 [755/755]	1600/1600 [755/755]	1600/1600 [755/755]	1600/1600 [755/755]
ARI Net Cooling Capacity Btu [kW]	48,000 [14.1]	48,000 [14.1]	48,000 [14.1]	48,000 [14.1]
Net Sensible Capacity Btu [kW]	35,500 [10.4]	35,500 [10.4]	35,500 [10.4]	35,500 [10.4]
Net Latent Capacity Btu [kW]	12,500 [3.7]	12,500 [3.7]	12,500 [3.7]	12,500 [3.7]
Net System Power kW	4.9	4.9	4.9	4.9
Heating Performance (Package Gas/Electric)⁴				
Heating Input Btu [kW]	100,000 [29.3]	135,000 [39.6]	80,000 [23.4]	100,000 [29.3]
Heating Output Btu [kW]	81,000 [23.7]	109,400 [32.1]	64,800 [19]	81,000 [23.7]
Temperature Rise Range °F [°C]	30-60 [16.7/33.3]	50-80 [27.8/44.4]	30-60 [16.7/33.3]	30-60 [16.7/33.3]
AFUE %	80	80	80	80
Steady State Efficiency (%)	81	81	81	81
No. Burners	5	6	4	5
No. Stages	1	1	1	1
Gas Connection Pipe Size in. [mm]	0.5 [12.7]	0.5 [12.7]	0.5 [12.7]	0.5 [12.7]
Compressor				
No./Type	1/Scroll	1/Scroll	1/Scroll	1/Scroll
Outdoor Sound Rating (dB)⁵				
	78	78	78	78
Outdoor Coil—Fin Type				
Tube Type	Louvered	Louvered	Louvered	Louvered
Tube Size in. [mm] OD	Smooth	Smooth	Smooth	Smooth
Face Area sq. ft. [sq. m]	0.375 [9.5]	0.375 [9.5]	0.375 [9.5]	0.375 [9.5]
Rows / FPI [FPcm]	16.91 [1.57]	16.91 [1.57]	16.91 [1.57]	16.91 [1.57]
	1 / 18 [7]	1 / 18 [7]	1 / 18 [7]	1 / 18 [7]
Indoor Coil—Fin Type				
Tube Type	Louvered	Louvered	Louvered	Louvered
Tube Size in. [mm]	Smooth	Smooth	Smooth	Smooth
Face Area sq. ft. [sq. m]	0.3125 [7.9]	0.3125 [7.9]	0.3125 [7.9]	0.3125 [7.9]
Rows / FPI [FPcm]	5.17 [0.48]	5.17 [0.48]	5.17 [0.48]	5.17 [0.48]
	4 / 13 [5]	4 / 13 [5]	4 / 13 [5]	4 / 13 [5]
Refrigerant Control	Capillary Tubes	Capillary Tubes	Capillary Tubes	Capillary Tubes
Drain Connection No./Size in. [mm]	1/1 [25.4]	1/1 [25.4]	1/1 [25.4]	1/1 [25.4]
Outdoor Fan—Type				
	Propeller	Propeller	Propeller	Propeller
No. Used/Diameter in. [mm]	1/24 [609.6]	1/24 [609.6]	1/24 [609.6]	1/24 [609.6]
Drive Type/No. Speeds	Direct/1	Direct/1	Direct/1	Direct/1
CFM [L/s]	4000 [1888]	4000 [1888]	4000 [1888]	4000 [1888]
No. Motors/HP	1 at 1/3 HP	1 at 1/3 HP	1 at 1/3 HP	1 at 1/3 HP
Motor RPM	1075	1075	1075	1075
Indoor Fan—Type				
	FC Centrifugal	FC Centrifugal	FC Centrifugal	FC Centrifugal
No. Used/Diameter in. [mm]	1/11x11 [279.4x279.4]	1/11x11 [279.4x279.4]	1/11x11 [279.4x279.4]	1/11x11 [279.4x279.4]
Drive Type/No. Speeds	Belt/Variable	Belt/Variable	Belt/Variable	Belt/Variable
No. Motors	1	1	1	1
Motor HP	1/2	1/2	3/4	3/4
Motor RPM	1725	1725	1725	1725
Motor Frame Size	56	56	56	56
Filter—Type				
	Disposable	Disposable	Disposable	Disposable
Furnished	Yes	Yes	Yes	Yes
(No.) Size Recommended in. [mm]	(1)1x16x25 [25x406x635]	(1)1x16x25 [25x406x635]	(1)1x16x25 [25x406x635]	(1)1x16x25 [25x406x635]
	(1)1x16x25 [25x406x635]	(1)1x16x25 [25x406x635]	(1)1x16x25 [25x406x635]	(1)1x16x25 [25x406x635]
Refrigerant Charge Oz. [g]				
	106 [3005]	106 [3005]	106 [3005]	106 [3005]
Weights				
Net Weight lbs. [kg]	573 [260]	578 [262]	573 [260]	573 [260]
Ship Weight lbs. [kg]	580 [263]	585 [265]	580 [263]	580 [263]

See Page 37 for Notes.

[] Designates Metric Conversions



NOM. SIZES 3-7.5 TONS [10.6-26.4 kW] ASHRAE 90.1-1999 COMPLIANT MODELS

Model RKKA- Series	A048CM13E	A048DK08E	A048DK10E	A048DK13E
Cooling Performance¹				
Gross Cooling Capacity Btu [kW]	50,000 [14.6]	50,000 [14.6]	50,000 [14.6]	50,000 [14.6]
EER/SEER ²	9.8/10.4	9.8/10.4	9.8/10.4	9.8/10.4
Nominal CFM/ARI Rated CFM [L/s]	1600/1600 [755/755]	1600/1600 [755/755]	1600/1600 [755/755]	1600/1600 [755/755]
ARI Net Cooling Capacity Btu [kW]	48,000 [14.1]	48,000 [14.1]	48,000 [14.1]	48,000 [14.1]
Net Sensible Capacity Btu [kW]	35,500 [10.4]	35,500 [10.4]	35,500 [10.4]	35,500 [10.4]
Net Latent Capacity Btu [kW]	12,500 [3.7]	12,500 [3.7]	12,500 [3.7]	12,500 [3.7]
Net System Power kW	4.9	4.9	4.9	4.9
Heating Performance (Package Gas/Electric)⁴				
Heating Input Btu [kW]	135,000 [39.6]	80,000 [23.4]	100,000 [29.3]	135,000 [39.6]
Heating Output Btu [kW]	109,400 [32.1]	64,800 [19]	81,000 [23.7]	109,400 [32.1]
Temperature Rise Range °F [°C]	50-80 [27.8/44.4]	30-60 [16.7/33.3]	30-60 [16.7/33.3]	50-80 [27.8/44.4]
AFUE %	80	80	80	80
Steady State Efficiency (%)	81	81	81	81
No. Burners	6	4	5	6
No. Stages	1	1	1	1
Gas Connection Pipe Size in. [mm]	0.5 [12.7]	0.5 [12.7]	0.5 [12.7]	0.5 [12.7]
Compressor				
No./Type	1/Scroll	1/Scroll	1/Scroll	1/Scroll
Outdoor Sound Rating (dB)⁵				
	78	78	78	78
Outdoor Coil—Fin Type				
Tube Type	Louvered	Louvered	Louvered	Louvered
Tube Size in. [mm] OD	0.375 [9.5]	0.375 [9.5]	0.375 [9.5]	0.375 [9.5]
Face Area sq. ft. [sq. m]	16.91 [1.57]	16.91 [1.57]	16.91 [1.57]	16.91 [1.57]
Rows / FPI [FPcm]	1 / 18 [7]	1 / 18 [7]	1 / 18 [7]	1 / 18 [7]
Indoor Coil—Fin Type				
Tube Type	Louvered	Louvered	Louvered	Louvered
Tube Size in. [mm]	0.3125 [7.9]	0.3125 [7.9]	0.3125 [7.9]	0.3125 [7.9]
Face Area sq. ft. [sq. m]	5.17 [0.48]	5.17 [0.48]	5.17 [0.48]	5.17 [0.48]
Rows / FPI [FPcm]	4 / 13 [5]	4 / 13 [5]	4 / 13 [5]	4 / 13 [5]
Refrigerant Control	Capillary Tubes	Capillary Tubes	Capillary Tubes	Capillary Tubes
Drain Connection No./Size in. [mm]	1/1 [25.4]	1/1 [25.4]	1/1 [25.4]	1/1 [25.4]
Outdoor Fan—Type				
No. Used/Diameter in. [mm]	Propeller	Propeller	Propeller	Propeller
Drive Type/No. Speeds	1/24 [609.6]	1/24 [609.6]	1/24 [609.6]	1/24 [609.6]
CFM [L/s]	Direct/1	Direct/1	Direct/1	Direct/1
No. Motors/HP	4000 [1888]	4000 [1888]	4000 [1888]	4000 [1888]
Motor RPM	1 at 1/3 HP	1 at 1/3 HP	1 at 1/3 HP	1 at 1/3 HP
	1075	1075	1075	1075
Indoor Fan—Type				
No. Used/Diameter in. [mm]	FC Centrifugal	FC Centrifugal	FC Centrifugal	FC Centrifugal
Drive Type/No. Speeds	1/11x11 [279.4x279.4]	1/11x11 [279.4x279.4]	1/11x11 [279.4x279.4]	1/11x11 [279.4x279.4]
No. Motors	Belt/Variable	Direct/3	Direct/3	Direct/3
Motor HP	1	1	1	1
Motor RPM	3/4	1/2	1/2	1/2
Motor Frame Size	1725	1725	1725	1725
	56	48	48	48
Filter—Type				
Furnished	Disposable	Disposable	Disposable	Disposable
(No.) Size Recommended in. [mm]	Yes	Yes	Yes	Yes
	(1)1x16x25 [25x406x635]	(1)1x16x25 [25x406x635]	(1)1x16x25 [25x406x635]	(1)1x16x25 [25x406x635]
	(1)1x16x25 [25x406x635]	(1)1x16x25 [25x406x635]	(1)1x16x25 [25x406x635]	(1)1x16x25 [25x406x635]
Refrigerant Charge Oz. [g]				
	106 [3005]	106 [3005]	106 [3005]	106 [3005]
Weights				
Net Weight lbs. [kg]	573 [260]	573 [260]	573 [260]	578 [262]
Ship Weight lbs. [kg]	580 [263]	580 [263]	580 [263]	585 [265]

CONTINUED →

See Page 37 for Notes.

[] Designates Metric Conversions



NOM. SIZES 3-7.5 TONS [10.6-26.4 kW] ASHRAE 90.1-1999 COMPLIANT MODELS

Model RKKA- Series	A048DL08E	A048DL10E	A048DL13E	A048DM08E
Cooling Performance¹				CONTINUED →
Gross Cooling Capacity Btu [kW]	50,000 [14.6]	50,000 [14.6]	50,000 [14.6]	50,000 [14.6]
EER/SEER ²	9.8/10.4	9.8/10.4	9.8/10.4	9.8/10.4
Nominal CFM/ARI Rated CFM [L/s]	1600/1600 [755/755]	1600/1600 [755/755]	1600/1600 [755/755]	1600/1600 [755/755]
ARI Net Cooling Capacity Btu [kW]	48,000 [14.1]	48,000 [14.1]	48,000 [14.1]	48,000 [14.1]
Net Sensible Capacity Btu [kW]	35,500 [10.4]	35,500 [10.4]	35,500 [10.4]	35,500 [10.4]
Net Latent Capacity Btu [kW]	12,500 [3.7]	12,500 [3.7]	12,500 [3.7]	12,500 [3.7]
Net System Power kW	4.9	4.9	4.9	4.9
Heating Performance (Package Gas/Electric)⁴				
Heating Input Btu [kW]	80,000 [23.4]	100,000 [29.3]	135,000 [39.6]	80,000 [23.4]
Heating Output Btu [kW]	64,800 [19]	81,000 [23.7]	109,400 [32.1]	64,800 [19]
Temperature Rise Range °F [°C]	30-60 [16.7/33.3]	30-60 [16.7/33.3]	50-80 [27.8/44.4]	30-60 [16.7/33.3]
AFUE %	80	80	80	80
Steady State Efficiency (%)	81	81	81	81
No. Burners	4	5	6	4
No. Stages	1	1	1	1
Gas Connection Pipe Size in. [mm]	0.5 [12.7]	0.5 [12.7]	0.5 [12.7]	0.5 [12.7]
Compressor				
No./Type	1/Scroll	1/Scroll	1/Scroll	1/Scroll
Outdoor Sound Rating (dB)⁵	78	78	78	78
Outdoor Coil—Fin Type	Louvered	Louvered	Louvered	Louvered
Tube Type	Smooth	Smooth	Smooth	Smooth
Tube Size in. [mm] OD	0.375 [9.5]	0.375 [9.5]	0.375 [9.5]	0.375 [9.5]
Face Area sq. ft. [sq. m]	16.91 [1.57]	16.91 [1.57]	16.91 [1.57]	16.91 [1.57]
Rows / FPI [FPcm]	1 / 18 [7]	1 / 18 [7]	1 / 18 [7]	1 / 18 [7]
Indoor Coil—Fin Type	Louvered	Louvered	Louvered	Louvered
Tube Type	Smooth	Smooth	Smooth	Smooth
Tube Size in. [mm]	0.3125 [7.9]	0.3125 [7.9]	0.3125 [7.9]	0.3125 [7.9]
Face Area sq. ft. [sq. m]	5.17 [0.48]	5.17 [0.48]	5.17 [0.48]	5.17 [0.48]
Rows / FPI [FPcm]	4 / 13 [5]	4 / 13 [5]	4 / 13 [5]	4 / 13 [5]
Refrigerant Control	Capillary Tubes	Capillary Tubes	Capillary Tubes	Capillary Tubes
Drain Connection No./Size in. [mm]	1/1 [25.4]	1/1 [25.4]	1/1 [25.4]	1/1 [25.4]
Outdoor Fan—Type	Propeller	Propeller	Propeller	Propeller
No. Used/Diameter in. [mm]	1/24 [609.6]	1/24 [609.6]	1/24 [609.6]	1/24 [609.6]
Drive Type/No. Speeds	Direct/1	Direct/1	Direct/1	Direct/1
CFM [L/s]	4000 [1888]	4000 [1888]	4000 [1888]	4000 [1888]
No. Motors/HP	1 at 1/3 HP	1 at 1/3 HP	1 at 1/3 HP	1 at 1/3 HP
Motor RPM	1075	1075	1075	1075
Indoor Fan—Type	FC Centrifugal	FC Centrifugal	FC Centrifugal	FC Centrifugal
No. Used/Diameter in. [mm]	1/11x11 [279.4x279.4]	1/11x11 [279.4x279.4]	1/11x11 [279.4x279.4]	1/11x11 [279.4x279.4]
Drive Type/No. Speeds	Belt/Variable	Belt/Variable	Belt/Variable	Belt/Variable
No. Motors	1	1	1	1
Motor HP	1/2	1/2	1/2	3/4
Motor RPM	1725	1725	1725	1725
Motor Frame Size	56	56	56	56
Filter—Type	Disposable	Disposable	Disposable	Disposable
Furnished	Yes	Yes	Yes	Yes
(No.) Size Recommended in. [mm]	(1)1x16x25 [25x406x635]	(1)1x16x25 [25x406x635]	(1)1x16x25 [25x406x635]	(1)1x16x25 [25x406x635]
	(1)1x16x25 [25x406x635]	(1)1x16x25 [25x406x635]	(1)1x16x25 [25x406x635]	(1)1x16x25 [25x406x635]
Refrigerant Charge Oz. [g]	106 [3005]	106 [3005]	106 [3005]	106 [3005]
Weights				
Net Weight lbs. [kg]	573 [260]	573 [260]	578 [262]	573 [260]
Ship Weight lbs. [kg]	580 [263]	580 [263]	585 [265]	580 [263]

See Page 37 for Notes.

[] Designates Metric Conversions



NOM. SIZES 3-7.5 TONS [10.6-26.4 kW] ASHRAE 90.1-1999 COMPLIANT MODELS

Model RKKA- Series	A048DM10E	A048DM13E	A048JK08E	A048JK08X
Cooling Performance¹				
CONTINUED →				
Gross Cooling Capacity Btu [kW]	50,000 [14.6]	50,000 [14.6]	50,000 [14.6]	50,000 [14.6]
EER/SEER ²	9.8/10.4	9.8/10.4	9.8/10.4	9.8/10.4
Nominal CFM/ARI Rated CFM [L/s]	1600/1600 [755/755]	1600/1600 [755/755]	1600/1600 [755/755]	1600/1600 [755/755]
ARI Net Cooling Capacity Btu [kW]	48,000 [14.1]	48,000 [14.1]	48,000 [14.1]	48,000 [14.1]
Net Sensible Capacity Btu [kW]	35,500 [10.4]	35,500 [10.4]	35,500 [10.4]	35,500 [10.4]
Net Latent Capacity Btu [kW]	12,500 [3.7]	12,500 [3.7]	12,500 [3.7]	12,500 [3.7]
Net System Power kW	4.9	4.9	4.9	4.9
Heating Performance (Package Gas/Electric)⁴				
Heating Input Btu [kW]	100,000 [29.3]	135,000 [39.6]	80,000 [23.4]	80,000 [23.4]
Heating Output Btu [kW]	81,000 [23.7]	109,400 [32.1]	62,500 [18.3]	62,500 [18.3]
Temperature Rise Range °F [°C]	30-60 [16.7/33.3]	50-80 [27.8/44.4]	30-60 [16.7/33.3]	30-60 [16.7/33.3]
AFUE %	80	80	80	80
Steady State Efficiency (%)	81	81	78.5	78.5
California Seasonal Eff. (%)	NA	NA	75.5	75.5
No. Burners	5	6	4	4
No. Stages	1	1	1	1
Gas Connection Pipe Size in. [mm]	0.5 [12.7]	0.5 [12.7]	0.5 [12.7]	0.5 [12.7]
Compressor				
No./Type	1/Scroll	1/Scroll	1/Scroll	1/Scroll
Outdoor Sound Rating (dB)⁵				
	78	78	78	78
Outdoor Coil—Fin Type				
Tube Type	Louvered	Louvered	Louvered	Louvered
Tube Size in. [mm] OD	0.375 [9.5]	0.375 [9.5]	0.375 [9.5]	0.375 [9.5]
Face Area sq. ft. [sq. m]	16.91 [1.57]	16.91 [1.57]	16.91 [1.57]	16.91 [1.57]
Rows / FPI [FPcm]	1 / 18 [7]	1 / 18 [7]	1 / 18 [7]	1 / 18 [7]
Indoor Coil—Fin Type				
Tube Type	Louvered	Louvered	Louvered	Louvered
Tube Size in. [mm]	0.3125 [7.9]	0.3125 [7.9]	0.3125 [7.9]	0.3125 [7.9]
Face Area sq. ft. [sq. m]	5.17 [0.48]	5.17 [0.48]	5.17 [0.48]	5.17 [0.48]
Rows / FPI [FPcm]	4 / 13 [5]	4 / 13 [5]	4 / 13 [5]	4 / 13 [5]
Refrigerant Control	Capillary Tubes	Capillary Tubes	Capillary Tubes	Capillary Tubes
Drain Connection No./Size in. [mm]	1/1 [25.4]	1/1 [25.4]	1/1 [25.4]	1/1 [25.4]
Outdoor Fan—Type				
No. Used/Diameter in. [mm]	Propeller	Propeller	Propeller	Propeller
Drive Type/No. Speeds	1/24 [609.6]	1/24 [609.6]	1/24 [609.6]	1/24 [609.6]
CFM [L/s]	Direct/1	Direct/1	Direct/1	Direct/1
No. Motors/HP	4000 [1888]	4000 [1888]	4000 [1888]	4000 [1888]
Motor RPM	1 at 1/3 HP	1 at 1/3 HP	1 at 1/3 HP	1 at 1/3 HP
	1075	1075	1075	1075
Indoor Fan—Type				
No. Used/Diameter in. [mm]	FC Centrifugal	FC Centrifugal	FC Centrifugal	FC Centrifugal
Drive Type/No. Speeds	1/11x11 [279.4x279.4]	1/11x11 [279.4x279.4]	1/11x11 [279.4x279.4]	1/11x11 [279.4x279.4]
No. Motors	Belt/Variable	Belt/Variable	Direct/3	Direct/3
Motor HP	1	1	1	1
Motor RPM	3/4	3/4	1/2	1/2
Motor Frame Size	1725	1725	1725	1725
	56	56	48	48
Filter—Type				
Furnished	Disposable	Disposable	Disposable	Disposable
(No.) Size Recommended in. [mm]	Yes	Yes	Yes	Yes
	(1)1x16x25 [25x406x635]	(1)1x16x25 [25x406x635]	(1)1x16x25 [25x406x635]	(1)1x16x25 [25x406x635]
	(1)1x16x25 [25x406x635]	(1)1x16x25 [25x406x635]	(1)1x16x25 [25x406x635]	(1)1x16x25 [25x406x635]
Refrigerant Charge Oz. [g]				
	106 [3005]	106 [3005]	106 [3005]	106 [3005]
Weights				
Net Weight lbs. [kg]	573 [260]	573 [260]	573 [260]	573 [260]
Ship Weight lbs. [kg]	580 [263]	580 [263]	580 [263]	580 [263]

See Page 37 for Notes.

[] Designates Metric Conversions



NOM. SIZES 3-7.5 TONS [10.6-26.4 kW] ASHRAE 90.1-1999 COMPLIANT MODELS

Model RKKA- Series	A048YL08E	A048YL10E	A048YL13E	A048YM08E
Cooling Performance¹				CONTINUED →
Gross Cooling Capacity Btu [kW]	50,000 [14.6]	50,000 [14.6]	50,000 [14.6]	50,000 [14.6]
EER/SEER ²	9.8/10.4	9.8/10.4	9.8/10.4	9.8/10.4
Nominal CFM/ARI Rated CFM [L/s]	1600/1600 [755/755]	1600/1600 [755/755]	1600/1600 [755/755]	1600/1600 [755/755]
ARI Net Cooling Capacity Btu [kW]	48,000 [14.1]	48,000 [14.1]	48,000 [14.1]	48,000 [14.1]
Net Sensible Capacity Btu [kW]	35,500 [10.4]	35,500 [10.4]	35,500 [10.4]	35,500 [10.4]
Net Latent Capacity Btu [kW]	12,500 [3.7]	12,500 [3.7]	12,500 [3.7]	12,500 [3.7]
Net System Power kW	4.9	4.9	4.9	4.9
Heating Performance (Package Gas/Electric)⁴				
Heating Input Btu [kW]	80,000 [23.4]	100,000 [29.3]	135,000 [39.6]	80,000 [23.4]
Heating Output Btu [kW]	64,800 [19]	81,000 [23.7]	109,400 [32.1]	64,800 [19]
Temperature Rise Range °F [°C]	30-60 [16.7/33.3]	30-60 [16.7/33.3]	50-80 [27.8/44.4]	30-60 [16.7/33.3]
AFUE %	80	80	80	80
Steady State Efficiency (%)	81	81	81	81
No. Burners	4	5	6	4
No. Stages	1	1	1	1
Gas Connection Pipe Size in. [mm]	0.5 [12.7]	0.5 [12.7]	0.5 [12.7]	0.5 [12.7]
Compressor				
No./Type	1/Scroll	1/Scroll	1/Scroll	1/Scroll
Outdoor Sound Rating (dB)⁵	78	78	78	78
Outdoor Coil—Fin Type	Louvered	Louvered	Louvered	Louvered
Tube Type	Smooth	Smooth	Smooth	Smooth
Tube Size in. [mm] OD	0.375 [9.5]	0.375 [9.5]	0.375 [9.5]	0.375 [9.5]
Face Area sq. ft. [sq. m]	16.91 [1.57]	16.91 [1.57]	16.91 [1.57]	16.91 [1.57]
Rows / FPI [FPcm]	1 / 18 [7]	1 / 18 [7]	1 / 18 [7]	1 / 18 [7]
Indoor Coil—Fin Type	Louvered	Louvered	Louvered	Louvered
Tube Type	Smooth	Smooth	Smooth	Smooth
Tube Size in. [mm]	0.3125 [7.9]	0.3125 [7.9]	0.3125 [7.9]	0.3125 [7.9]
Face Area sq. ft. [sq. m]	5.17 [0.48]	5.17 [0.48]	5.17 [0.48]	5.17 [0.48]
Rows / FPI [FPcm]	4 / 13 [5]	4 / 13 [5]	4 / 13 [5]	4 / 13 [5]
Refrigerant Control	Capillary Tubes	Capillary Tubes	Capillary Tubes	Capillary Tubes
Drain Connection No./Size in. [mm]	1/1 [25.4]	1/1 [25.4]	1/1 [25.4]	1/1 [25.4]
Outdoor Fan—Type	Propeller	Propeller	Propeller	Propeller
No. Used/Diameter in. [mm]	1/24 [609.6]	1/24 [609.6]	1/24 [609.6]	1/24 [609.6]
Drive Type/No. Speeds	Direct/1	Direct/1	Direct/1	Direct/1
CFM [L/s]	4000 [1888]	4000 [1888]	4000 [1888]	4000 [1888]
No. Motors/HP	1 at 1/3 HP	1 at 1/3 HP	1 at 1/3 HP	1 at 1/3 HP
Motor RPM	1075	1075	1075	1075
Indoor Fan—Type	FC Centrifugal	FC Centrifugal	FC Centrifugal	FC Centrifugal
No. Used/Diameter in. [mm]	1/11x11 [279.4x279.4]	1/11x11 [279.4x279.4]	1/11x11 [279.4x279.4]	1/11x11 [279.4x279.4]
Drive Type/No. Speeds	Belt/Variable	Belt/Variable	Belt/Variable	Belt/Variable
No. Motors	1	1	1	1
Motor HP	1/2	1/2	1/2	1/2
Motor RPM	1725	1725	1725	1725
Motor Frame Size	56	56	56	56
Filter—Type	Disposable	Disposable	Disposable	Disposable
Furnished	Yes	Yes	Yes	Yes
(No.) Size Recommended in. [mm]	(1)1x16x25 [25x406x635] (1)1x16x25 [25x406x635]	(1)1x16x25 [25x406x635] (1)1x16x25 [25x406x635]	(1)1x16x25 [25x406x635] (1)1x16x25 [25x406x635]	(1)1x48.3x25 [25x1227x635] (1)1x8.5x25 [25x216x635]
Refrigerant Charge Oz. [g]	106 [3005]	106 [3005]	106 [3005]	106 [3005]
Weights				
Net Weight lbs. [kg]	573 [260]	573 [260]	578 [262]	573 [260]
Ship Weight lbs. [kg]	580 [263]	580 [263]	585 [265]	580 [263]

See Page 37 for Notes.

[] Designates Metric Conversions



NOM. SIZES 3-7.5 TONS [10.6-26.4 kW] ASHRAE 90.1-1999 COMPLIANT MODELS

Model RKKA- Series	A048YM10E	A048YM13E	A060CK10E	A060CK13E
Cooling Performance¹				
CONTINUED →				
Gross Cooling Capacity Btu [kW]	50,000 [14.6]	50,000 [14.6]	63,000 [18.5]	63,000 [18.5]
EER/SEER ²	9.8/10.4	9.8/10.4	9.3/10.1	9.3/10.1
Nominal CFM/ARI Rated CFM [L/s]	1600/1600 [755/755]	1600/1600 [755/755]	2000/2000 [944/944]	2000/2000 [944/944]
ARI Net Cooling Capacity Btu [kW]	48,000 [14.1]	48,000 [14.1]	60,000 [17.6]	60,000 [17.6]
Net Sensible Capacity Btu [kW]	35,500 [10.4]	35,500 [10.4]	44,000 [12.9]	44,000 [12.9]
Net Latent Capacity Btu [kW]	12,500 [3.7]	12,500 [3.7]	16,000 [4.7]	16,000 [4.7]
Net System Power kW	4.9	4.9	6.5	6.5
Heating Performance (Package Gas/Electric)⁴				
Heating Input Btu [kW]	100,000 [29.3]	135,000 [39.6]	100,000 [29.3]	135,000 [39.6]
Heating Output Btu [kW]	81,000 [23.7]	109,400 [32.1]	81,000 [23.7]	109,400 [32.1]
Temperature Rise Range °F [°C]	30-60 [16.7/33.3]	50-80 [27.8/44.4]	40-70 [22.2/38.9]	40-70 [22.2/38.9]
AFUE %	80	80	80	80
Steady State Efficiency (%)	81	81	81	81
No. Burners	5	6	5	6
No. Stages	1	1	1	1
Gas Connection Pipe Size in. [mm]	0.5 [12.7]	0.5 [12.7]	0.5 [12.7]	0.5 [12.7]
Compressor				
No./Type	1/Scroll	1/Scroll	1/Scroll	1/Scroll
Outdoor Sound Rating (dB)⁵				
	78	78	78	78
Outdoor Coil—Fin Type				
Tube Type	Louvered	Louvered	Louvered	Louvered
Tube Size in. [mm] OD	0.375 [9.5]	0.375 [9.5]	0.375 [9.5]	0.375 [9.5]
Face Area sq. ft. [sq. m]	16.91 [1.57]	16.91 [1.57]	16.56 [1.54]	16.56 [1.54]
Rows / FPI [FPcm]	1 / 18 [7]	1 / 18 [7]	1.5 / 18 [7]	1.5 / 18 [7]
Indoor Coil—Fin Type				
Tube Type	Louvered	Louvered	Louvered	Louvered
Tube Size in. [mm]	0.3125 [7.9]	0.3125 [7.9]	0.3125 [7.9]	0.3125 [7.9]
Face Area sq. ft. [sq. m]	5.17 [0.48]	5.17 [0.48]	5.17 [0.48]	5.17 [0.48]
Rows / FPI [FPcm]	4 / 13 [5]	4 / 13 [5]	5 / 14 [6]	5 / 14 [6]
Refrigerant Control	Capillary Tubes	Capillary Tubes	Capillary Tubes	Capillary Tubes
Drain Connection No./Size in. [mm]	1/1 [25.4]	1/1 [25.4]	1/1 [25.4]	1/1 [25.4]
Outdoor Fan—Type				
No. Used/Diameter in. [mm]	Propeller	Propeller	Propeller	Propeller
Drive Type/No. Speeds	1/24 [609.6]	1/24 [609.6]	1/24 [609.6]	1/24 [609.6]
CFM [L/s]	Direct/1	Direct/1	Direct/1	Direct/1
No. Motors/HP	4000 [1888]	4000 [1888]	3700 [1746]	3700 [1746]
Motor RPM	1 at 1/3 HP	1 at 1/3 HP	1 at 1/3 HP	1 at 1/3 HP
	1075	1075	1075	1075
Indoor Fan—Type				
No. Used/Diameter in. [mm]	FC Centrifugal	FC Centrifugal	FC Centrifugal	FC Centrifugal
Drive Type/No. Speeds	1/11x11 [279.4x279.4]	1/11x11 [279.4x279.4]	1/11x11 [279.4x279.4]	1/11x11 [279.4x279.4]
No. Motors	Belt/Variable	Belt/Variable	Direct/3	Direct/3
Motor HP	1	1	1	1
Motor RPM	1/2	1/2	3/4	3/4
Motor Frame Size	1725	1725	1725	1725
	56	56	56	56
Filter—Type				
Furnished	Disposable	Disposable	Disposable	Disposable
(No.) Size Recommended in. [mm]	Yes	Yes	Yes	Yes
	(1)1x16x25 [25x406x635]	(1)1x16x25 [25x406x635]	(1)1x16x25 [25x406x635]	(1)1x16x25 [25x406x635]
	(1)1x16x25 [25x406x635]	(1)1x16x25 [25x406x635]	(1)1x16x25 [25x406x635]	(1)1x16x25 [25x406x635]
Refrigerant Charge Oz. [g]				
	106 [3005]	106 [3005]	131 [3714]	131 [3714]
Weights				
Net Weight lbs. [kg]	573 [260]	573 [260]	573 [260]	578 [262]
Ship Weight lbs. [kg]	580 [263]	580 [263]	580 [263]	585 [265]

See Page 37 for Notes.

[] Designates Metric Conversions



NOM. SIZES 3-7.5 TONS [10.6-26.4 kW] ASHRAE 90.1-1999 COMPLIANT MODELS

Model RKKA- Series	A060CL10E	A060CL13E	A060CM10E	A060CM13E
Cooling Performance¹				CONTINUED →
Gross Cooling Capacity Btu [kW]	63,000 [18.5]	63,000 [18.5]	63,000 [18.5]	63,000 [18.5]
EER/SEER ²	9.3/10.1	9.3/10.1	9.3/10.1	9.3/10.1
Nominal CFM/ARI Rated CFM [L/s]	2000/2000 [944/944]	2000/2000 [944/944]	2000/2000 [944/944]	2000/2000 [944/944]
ARI Net Cooling Capacity Btu [kW]	60,000 [17.6]	60,000 [17.6]	60,000 [17.6]	60,000 [17.6]
Net Sensible Capacity Btu [kW]	44,000 [12.9]	44,000 [12.9]	44,000 [12.9]	44,000 [12.9]
Net Latent Capacity Btu [kW]	16,000 [4.7]	16,000 [4.7]	16,000 [4.7]	16,000 [4.7]
Net System Power kW	6.5	6.5	6.5	6.5
Heating Performance (Package Gas/Electric)⁴				
Heating Input Btu [kW]	100,000 [29.3]	135,000 [39.6]	100,000 [29.3]	135,000 [39.6]
Heating Output Btu [kW]	81,000 [23.7]	109,400 [32.1]	81,000 [23.7]	109,400 [32.1]
Temperature Rise Range °F [°C]	25-55 [13.9/30.6]	40-70 [22.2/38.9]	25-55 [13.9/30.6]	40-70 [22.2/38.9]
AFUE %	80	80	80	80
Steady State Efficiency (%)	81	81	81	81
No. Burners	5	6	5	6
No. Stages	1	1	1	1
Gas Connection Pipe Size in. [mm]	0.5 [12.7]	0.5 [12.7]	0.5 [12.7]	0.5 [12.7]
Compressor				
No./Type	1/Scroll	1/Scroll	1/Scroll	1/Scroll
Outdoor Sound Rating (dB)⁵				
	78	78	78	78
Outdoor Coil—Fin Type				
Tube Type	Louvered	Louvered	Louvered	Louvered
Tube Size in. [mm] OD	0.375 [9.5]	0.375 [9.5]	0.375 [9.5]	0.375 [9.5]
Face Area sq. ft. [sq. m]	16.56 [1.54]	16.56 [1.54]	16.56 [1.54]	16.56 [1.54]
Rows / FPI [FPcm]	1.5 / 18 [7]	1.5 / 18 [7]	1.5 / 18 [7]	1.5 / 18 [7]
Indoor Coil—Fin Type				
Tube Type	Louvered	Louvered	Louvered	Louvered
Tube Size in. [mm]	0.3125 [7.9]	0.3125 [7.9]	0.3125 [7.9]	0.3125 [7.9]
Face Area sq. ft. [sq. m]	5.17 [0.48]	5.17 [0.48]	5.17 [0.48]	5.17 [0.48]
Rows / FPI [FPcm]	5 / 14 [6]	5 / 14 [6]	5 / 14 [6]	5 / 14 [6]
Refrigerant Control	Capillary Tubes	Capillary Tubes	Capillary Tubes	Capillary Tubes
Drain Connection No./Size in. [mm]	1/1 [25.4]	1/1 [25.4]	1/1 [25.4]	1/1 [25.4]
Outdoor Fan—Type				
No. Used/Diameter in. [mm]	Propeller 1/24 [609.6]	Propeller 1/24 [609.6]	Propeller 1/24 [609.6]	Propeller 1/24 [609.6]
Drive Type/No. Speeds	Direct/1	Direct/1	Direct/1	Direct/1
CFM [L/s]	3700 [1746]	3700 [1746]	3700 [1746]	3700 [1746]
No. Motors/HP	1 at 1/3 HP	1 at 1/3 HP	1 at 1/3 HP	1 at 1/3 HP
Motor RPM	1075	1075	1075	1075
Indoor Fan—Type				
No. Used/Diameter in. [mm]	FC Centrifugal 1/11x11 [279.4x279.4]	FC Centrifugal 1/11x11 [279.4x279.4]	FC Centrifugal 1/11x11 [279.4x279.4]	FC Centrifugal 1/11x11 [279.4x279.4]
Drive Type/No. Speeds	Belt/Variable	Belt/Variable	Belt/Variable	Belt/Variable
No. Motors	1	1	1	1
Motor HP	3/4	3/4	1	1
Motor RPM	1725	1725	1725	1725
Motor Frame Size	56	56	56	56
Filter—Type				
Furnished	Disposable Yes	Disposable Yes	Disposable Yes	Disposable Yes
(No.) Size Recommended in. [mm]	(1)1x16x25 [25x406x635] (1)1x16x25 [25x406x635]	(1)1x16x25 [25x406x635] (1)1x16x25 [25x406x635]	(1)1x16x25 [25x406x635] (1)1x16x25 [25x406x635]	(1)1x16x25 [25x406x635] (1)1x16x25 [25x406x635]
Refrigerant Charge Oz. [g]				
	131 [3714]	131 [3714]	131 [3714]	131 [3714]
Weights				
Net Weight lbs. [kg]	573 [260]	578 [262]	573 [260]	573 [260]
Ship Weight lbs. [kg]	580 [263]	585 [265]	580 [263]	580 [263]

See Page 37 for Notes.

[] Designates Metric Conversions



NOM. SIZES 3-7.5 TONS [10.6-26.4 kW] ASHRAE 90.1-1999 COMPLIANT MODELS

Model RKKA- Series	A060DK10E	A060DK13E	A060DL10E	A060DL13E
Cooling Performance¹				
Gross Cooling Capacity Btu [kW]	63,000 [18.5]	63,000 [18.5]	63,000 [18.5]	63,000 [18.5]
EER/SEER ²	9.3/10.1	9.3/10.1	9.3/10.1	9.3/10.1
Nominal CFM/ARI Rated CFM [L/s]	2000/2000 [944/944]	2000/2000 [944/944]	2000/2000 [944/944]	2000/2000 [944/944]
ARI Net Cooling Capacity Btu [kW]	60,000 [17.6]	60,000 [17.6]	60,000 [17.6]	60,000 [17.6]
Net Sensible Capacity Btu [kW]	44,000 [12.9]	44,000 [12.9]	44,000 [12.9]	44,000 [12.9]
Net Latent Capacity Btu [kW]	16,000 [4.7]	16,000 [4.7]	16,000 [4.7]	16,000 [4.7]
Net System Power kW	6.5	6.5	6.5	6.5
Heating Performance (Package Gas/Electric)⁴				
Heating Input Btu [kW]	100,000 [29.3]	135,000 [39.6]	100,000 [29.3]	135,000 [39.6]
Heating Output Btu [kW]	81,000 [23.7]	109,400 [32.1]	81,000 [23.7]	109,400 [32.1]
Temperature Rise Range °F [°C]	25-55 [13.9/30.6]	40-70 [22.2/38.9]	25-55 [13.9/30.6]	40-70 [22.2/38.9]
AFUE %	80	80	80	80
Steady State Efficiency (%)	81	81	81	81
No. Burners	5	6	5	6
No. Stages	1	1	1	1
Gas Connection Pipe Size in. [mm]	0.5 [12.7]	0.5 [12.7]	0.5 [12.7]	0.5 [12.7]
Compressor				
No./Type	1/Scroll	1/Scroll	1/Scroll	1/Scroll
Outdoor Sound Rating (dB)⁵				
	78	78	78	78
Outdoor Coil—Fin Type				
Tube Type	Louvered	Louvered	Louvered	Louvered
Tube Size in. [mm] OD	0.375 [9.5]	0.375 [9.5]	0.375 [9.5]	0.375 [9.5]
Face Area sq. ft. [sq. m]	16.56 [1.54]	16.56 [1.54]	16.56 [1.54]	16.56 [1.54]
Rows / FPI [FPcm]	1.5 / 18 [7]	1.5 / 18 [7]	1.5 / 18 [7]	1.5 / 18 [7]
Indoor Coil—Fin Type				
Tube Type	Louvered	Louvered	Louvered	Louvered
Tube Size in. [mm]	0.3125 [7.9]	0.3125 [7.9]	0.3125 [7.9]	0.3125 [7.9]
Face Area sq. ft. [sq. m]	5.17 [0.48]	5.17 [0.48]	5.17 [0.48]	5.17 [0.48]
Rows / FPI [FPcm]	5 / 14 [6]	5 / 14 [6]	5 / 14 [6]	5 / 14 [6]
Refrigerant Control	Capillary Tubes	Capillary Tubes	Capillary Tubes	Capillary Tubes
Drain Connection No./Size in. [mm]	1/1 [25.4]	1/1 [25.4]	1/1 [25.4]	1/1 [25.4]
Outdoor Fan—Type				
No. Used/Diameter in. [mm]	Propeller	Propeller	Propeller	Propeller
Drive Type/No. Speeds	1/24 [609.6]	1/24 [609.6]	1/24 [609.6]	1/24 [609.6]
CFM [L/s]	Direct/1	Direct/1	Direct/1	Direct/1
No. Motors/HP	3700 [1746]	3700 [1746]	3700 [1746]	3700 [1746]
Motor RPM	1 at 1/3 HP	1 at 1/3 HP	1 at 1/3 HP	1 at 1/3 HP
	1075	1075	1075	1075
Indoor Fan—Type				
No. Used/Diameter in. [mm]	FC Centrifugal	FC Centrifugal	FC Centrifugal	FC Centrifugal
Drive Type/No. Speeds	1/11x11 [279.4x279.4]	1/11x11 [279.4x279.4]	1/11x11 [279.4x279.4]	1/11x11 [279.4x279.4]
No. Motors	Direct/3	Direct/3	Belt/Variable	Belt/Variable
Motor HP	1	1	1	1
Motor RPM	3/4	3/4	3/4	3/4
Motor Frame Size	1725	1725	1725	1725
	56	56	56	56
Filter—Type				
Furnished	Disposable	Disposable	Disposable	Disposable
(No.) Size Recommended in. [mm]	Yes	Yes	Yes	Yes
	(1)1x16x25 [25x406x635]	(1)1x16x25 [25x406x635]	(1)1x16x25 [25x406x635]	(1)1x16x25 [25x406x635]
	(1)1x16x25 [25x406x635]	(1)1x16x25 [25x406x635]	(1)1x16x25 [25x406x635]	(1)1x16x25 [25x406x635]
Refrigerant Charge Oz. [g]				
	131 [3714]	131 [3714]	131 [3714]	131 [3714]
Weights				
Net Weight lbs. [kg]	573 [260]	578 [262]	573 [260]	578 [262]
Ship Weight lbs. [kg]	580 [263]	585 [265]	580 [263]	585 [265]

CONTINUED →

See Page 37 for Notes.

[] Designates Metric Conversions



NOM. SIZES 3-7.5 TONS [10.6-26.4 kW] ASHRAE 90.1-1999 COMPLIANT MODELS

Model RKKA- Series	A060DM10E	A060DM13E	A060YM10E	A060YM13E
Cooling Performance¹				CONTINUED →
Gross Cooling Capacity Btu [kW]	63,000 [18.5]	63,000 [18.5]	63,000 [18.5]	63,000 [18.5]
EER/SEER ²	9.3/10.1	9.3/10.1	9.3/10.1	9.3/10.1
Nominal CFM/ARI Rated CFM [L/s]	2000/2000 [944/944]	2000/2000 [944/944]	2000/2000 [944/944]	2000/2000 [944/944]
ARI Net Cooling Capacity Btu [kW]	60,000 [17.6]	60,000 [17.6]	60,000 [17.6]	60,000 [17.6]
Net Sensible Capacity Btu [kW]	44,000 [12.9]	44,000 [12.9]	44,000 [12.9]	44,000 [12.9]
Net Latent Capacity Btu [kW]	16,000 [4.7]	16,000 [4.7]	16,000 [4.7]	16,000 [4.7]
Net System Power kW	6.5	6.5	6.5	6.5
Heating Performance (Package Gas/Electric)⁴				
Heating Input Btu [kW]	100,000 [29.3]	135,000 [39.6]	100,000 [29.3]	135,000 [39.6]
Heating Output Btu [kW]	81,000 [23.7]	109,400 [32.1]	81,000 [23.7]	109,400 [32.1]
Temperature Rise Range °F [°C]	25-55 [13.9/30.6]	40-70 [22.2/38.9]	25-55 [13.9/30.6]	40-70 [22.2/38.9]
AFUE %	80	80	80	80
Steady State Efficiency (%)	81	81	81	81
California Seasonal Eff. (%)	—	—	—	—
No. Burners	5	6	5	6
No. Stages	1	1	1	1
Gas Connection Pipe Size in. [mm]	0.5 [12.7]	0.5 [12.7]	0.5 [12.7]	0.5 [12.7]
Compressor				
No./Type	1/Scroll	1/Scroll	1/Scroll	1/Scroll
Outdoor Sound Rating (dB)⁵				
	78	78	78	78
Outdoor Coil—Fin Type				
Tube Type	Louvered	Louvered	Louvered	Louvered
Tube Size in. [mm] OD	0.375 [9.5]	0.375 [9.5]	0.375 [9.5]	0.375 [9.5]
Face Area sq. ft. [sq. m]	16.56 [1.54]	16.56 [1.54]	16.56 [1.54]	16.56 [1.54]
Rows / FPI [FPcm]	1.5 / 18 [7]	1.5 / 18 [7]	1.5 / 18 [7]	1.5 / 18 [7]
Indoor Coil—Fin Type				
Tube Type	Louvered	Louvered	Louvered	Louvered
Tube Size in. [mm]	0.3125 [7.9]	0.3125 [7.9]	0.3125 [7.9]	0.3125 [7.9]
Face Area sq. ft. [sq. m]	5.17 [0.48]	5.17 [0.48]	5.17 [0.48]	5.17 [0.48]
Rows / FPI [FPcm]	5 / 14 [6]	5 / 14 [6]	5 / 14 [6]	5 / 14 [6]
Refrigerant Control	Capillary Tubes	Capillary Tubes	Capillary Tubes	Capillary Tubes
Drain Connection No./Size in. [mm]	1/1 [25.4]	1/1 [25.4]	1/1 [25.4]	1/1 [25.4]
Outdoor Fan—Type				
No. Used/Diameter in. [mm]	Propeller 1/24 [609.6]	Propeller 1/24 [609.6]	Propeller 1/24 [609.6]	Propeller 1/24 [609.6]
Drive Type/No. Speeds	Direct/1	Direct/1	Direct/1	Direct/1
CFM [L/s]	3700 [1746]	3700 [1746]	3700 [1746]	3700 [1746]
No. Motors/HP	1 at 1/3 HP	1 at 1/3 HP	1 at 1/3 HP	1 at 1/3 HP
Motor RPM	1075	1075	1075	1075
Indoor Fan—Type				
No. Used/Diameter in. [mm]	FC Centrifugal 1/11x11 [279.4x279.4]	FC Centrifugal 1/11x11 [279.4x279.4]	FC Centrifugal 1/11x11 [279.4x279.4]	FC Centrifugal 1/11x11 [279.4x279.4]
Drive Type/No. Speeds	Belt/Variable	Belt/Variable	Belt/Variable	Belt/Variable
No. Motors	1	1	1	1
Motor HP	1	1	1	1
Motor RPM	1725	1725	1725	1725
Motor Frame Size	56	56	56	56
Filter—Type				
Furnished	Disposable Yes	Disposable Yes	Disposable Yes	Disposable Yes
(No.) Size Recommended in. [mm]	(1)1x16x25 [25x406x635] (1)1x16x25 [25x406x635]	(1)1x16x25 [25x406x635] (1)1x16x25 [25x406x635]	(1)1x16x25 [25x406x635] (1)1x16x25 [25x406x635]	(1)1x16x25 [25x406x635] (1)1x16x25 [25x406x635]
Refrigerant Charge Oz. [g]				
	131 [3714]	131 [3714]	131 [3714]	131 [3714]
Weights				
Net Weight lbs. [kg]	573 [260]	573 [260]	573 [260]	573 [260]
Ship Weight lbs. [kg]	580 [263]	580 [263]	580 [263]	580 [263]

See Page 37 for Notes.

[] Designates Metric Conversions



NOM. SIZES 3-7.5 TONS [10.6-26.4 kW] ASHRAE 90.1-1989 COMPLIANT MODELS

Model RKKA- Series	A073CL10E	A073CL13E	A073CM10E	A073CM13E
Cooling Performance¹				CONTINUED →
Gross Cooling Capacity Btu [kW]	75,000 [22]	75,000 [22]	75,000 [22]	75,000 [22]
EER/SEER ²	9.8/NA	9.8/NA	9.8/NA	9.8/NA
Nominal CFM/ARI Rated CFM [L/s]	2400/2200 [1133/1038]	2400/2200 [1133/1038]	2400/2200 [1133/1038]	2400/2200 [1133/1038]
ARI Net Cooling Capacity Btu [kW]	72,000 [21.1]	72,000 [21.1]	72,000 [21.1]	72,000 [21.1]
Net Sensible Capacity Btu [kW]	51,500 [15.1]	51,500 [15.1]	51,500 [15.1]	51,500 [15.1]
Net Latent Capacity Btu [kW]	20,500 [6]	20,500 [6]	20,500 [6]	20,500 [6]
Net System Power kW	7.3	7.3	7.3	7.3
Heating Performance (Package Gas/Electric)⁴				
Heating Input Btu [kW]	100,000 [29.3]	135,000 [39.6]	100,000 [29.3]	135,000 [39.6]
Heating Output Btu [kW]	81,000 [23.7]	109,400 [32.1]	81,000 [23.7]	109,400 [32.1]
Temperature Rise Range °F [°C]	20-50 [11.1/27.8]	30-60 [16.7/33.3]	20-50 [11.1/27.8]	30-60 [16.7/33.3]
AFUE %	80	80	80	80
Steady State Efficiency (%)	81	81	81	81
No. Burners	5	6	5	6
No. Stages	1	1	1	1
Gas Connection Pipe Size in. [mm]	0.5 [12.7]	0.5 [12.7]	0.5 [12.7]	0.5 [12.7]
Compressor				
No./Type	1/Scroll	1/Scroll	1/Scroll	1/Scroll
Outdoor Sound Rating (dB)⁵	83	83	83	83
Outdoor Coil—Fin Type	Louvered	Louvered	Louvered	Louvered
Tube Type	Rifled	Rifled	Rifled	Rifled
Tube Size in. [mm] OD	0.375 [9.5]	0.375 [9.5]	0.375 [9.5]	0.375 [9.5]
Face Area sq. ft. [sq. m]	16.56 [1.54]	16.56 [1.54]	16.56 [1.54]	16.56 [1.54]
Rows / FPI [FPcm]	2 / 22 [9]	2 / 22 [9]	2 / 22 [9]	2 / 22 [9]
Indoor Coil—Fin Type	Louvered	Louvered	Louvered	Louvered
Tube Type	Rifled	Rifled	Rifled	Rifled
Tube Size in. [mm]	0.3125 [7.9]	0.3125 [7.9]	0.3125 [7.9]	0.3125 [7.9]
Face Area sq. ft. [sq. m]	5.17 [0.48]	5.17 [0.48]	5.17 [0.48]	5.17 [0.48]
Rows / FPI [FPcm]	5 / 13 [5]	5 / 13 [5]	5 / 13 [5]	5 / 13 [5]
Refrigerant Control	TX Valves	TX Valves	TX Valves	TX Valves
Drain Connection No./Size in. [mm]	1/1 [25.4]	1/1 [25.4]	1/1 [25.4]	1/1 [25.4]
Outdoor Fan—Type	Propeller	Propeller	Propeller	Propeller
No. Used/Diameter in. [mm]	1/24 [609.6]	1/24 [609.6]	1/24 [609.6]	1/24 [609.6]
Drive Type/No. Speeds	Direct/1	Direct/1	Direct/1	Direct/1
CFM [L/s]	4000 [1888]	4000 [1888]	4000 [1888]	4000 [1888]
No. Motors/HP	1 at 1/3 HP	1 at 1/3 HP	1 at 1/3 HP	1 at 1/3 HP
Motor RPM	1075	1075	1075	1075
Indoor Fan—Type	FC Centrifugal	FC Centrifugal	FC Centrifugal	FC Centrifugal
No. Used/Diameter in. [mm]	1/11x12 [279.4x304.8]	1/11x12 [279.4x304.8]	1/11x12 [279.4x304.8]	1/11x12 [279.4x304.8]
Drive Type/No. Speeds	Belt/Variable	Belt/Variable	Belt/Variable	Belt/Variable
No. Motors	1	1	1	1
Motor HP	1 1/2	1 1/2	1 1/2	1 1/2
Motor RPM	1725	1725	1725	1725
Motor Frame Size	56	56	56	56
Filter—Type	Disposable	Disposable	Disposable	Disposable
Furnished	Yes	Yes	Yes	Yes
(No.) Size Recommended in. [mm]	(1)1x16x25 [25x406x635]	(1)1x16x25 [25x406x635]	(1)1x16x25 [25x406x635]	(1)1x16x25 [25x406x635]
	(1)1x16x25 [25x406x635]	(1)1x16x25 [25x406x635]	(1)1x16x25 [25x406x635]	(1)1x16x25 [25x406x635]
Refrigerant Charge Oz. [g]	176 [4990]	176 [4990]	176 [4990]	176 [4990]
Weights				
Net Weight lbs. [kg]	608 [276]	608 [276]	608 [276]	608 [276]
Ship Weight lbs. [kg]	615 [279]	615 [279]	615 [279]	615 [279]

See Page 37 for Notes.

[] Designates Metric Conversions



NOM. SIZES 3-7.5 TONS [10.6-26.4 kW] ASHRAE 90.1-1989 COMPLIANT MODELS

Model RKKA- Series	A073DL10E	A073DL13E	A073DM10E	A073DM13E
Cooling Performance¹				
Gross Cooling Capacity Btu [kW]	75,000 [22]	75,000 [22]	75,000 [22]	75,000 [22]
EER/SEER ²	9.8/NA	9.8/NA	9.8/NA	9.8/NA
Nominal CFM/ARI Rated CFM [L/s]	2400/2200 [1133/1038]	2400/2200 [1133/1038]	2400/2200 [1133/1038]	2400/2200 [1133/1038]
ARI Net Cooling Capacity Btu [kW]	72,000 [21.1]	72,000 [21.1]	72,000 [21.1]	72,000 [21.1]
Net Sensible Capacity Btu [kW]	51,500 [15.1]	51,500 [15.1]	51,500 [15.1]	51,500 [15.1]
Net Latent Capacity Btu [kW]	20,500 [6]	20,500 [6]	20,500 [6]	20,500 [6]
Net System Power kW	7.3	7.3	7.3	7.3
Heating Performance (Package Gas/Electric)⁴				
Heating Input Btu [kW]	100,000 [29.3]	135,000 [39.6]	100,000 [29.3]	135,000 [39.6]
Heating Output Btu [kW]	81,000 [23.7]	109,400 [32.1]	81,000 [23.7]	109,400 [32.1]
Temperature Rise Range °F [°C]	20-50 [11.1/27.8]	30-60 [16.7/33.3]	20-50 [11.1/27.8]	30-60 [16.7/33.3]
AFUE %	80	80	80	80
Steady State Efficiency (%)	81	81	81	81
No. Burners	5	6	5	6
No. Stages	1	1	1	1
Gas Connection Pipe Size in. [mm]	0.5 [12.7]	0.5 [12.7]	0.5 [12.7]	0.5 [12.7]
Compressor				
No./Type	1/Scroll	1/Scroll	1/Scroll	1/Scroll
Outdoor Sound Rating (dB)⁵				
	83	83	83	83
Outdoor Coil—Fin Type				
Tube Type	Louvered	Louvered	Louvered	Louvered
Tube Size in. [mm] OD	Rifled	Rifled	Rifled	Rifled
Face Area sq. ft. [sq. m]	0.375 [9.5]	0.375 [9.5]	0.375 [9.5]	0.375 [9.5]
Rows / FPI [FPcm]	16.56 [1.54]	16.56 [1.54]	16.56 [1.54]	16.56 [1.54]
	2 / 22 [9]	2 / 22 [9]	2 / 22 [9]	2 / 22 [9]
Indoor Coil—Fin Type				
Tube Type	Louvered	Louvered	Louvered	Louvered
Tube Size in. [mm]	Rifled	Rifled	Rifled	Rifled
Face Area sq. ft. [sq. m]	0.3125 [7.9]	0.3125 [7.9]	0.3125 [7.9]	0.3125 [7.9]
Rows / FPI [FPcm]	5.17 [0.48]	5.17 [0.48]	5.17 [0.48]	5.17 [0.48]
	5 / 13 [5]	5 / 13 [5]	5 / 13 [5]	5 / 13 [5]
Refrigerant Control	TX Valves	TX Valves	TX Valves	TX Valves
Drain Connection No./Size in. [mm]	1/1 [25.4]	1/1 [25.4]	1/1 [25.4]	1/1 [25.4]
Outdoor Fan—Type				
No. Used/Diameter in. [mm]	Propeller	Propeller	Propeller	Propeller
Drive Type/No. Speeds	1/24 [609.6]	1/24 [609.6]	1/24 [609.6]	1/24 [609.6]
CFM [L/s]	Direct/1	Direct/1	Direct/1	Direct/1
No. Motors/HP	4000 [1888]	4000 [1888]	4000 [1888]	4000 [1888]
Motor RPM	1 at 1/3 HP	1 at 1/3 HP	1 at 1/3 HP	1 at 1/3 HP
	1075	1075	1075	1075
Indoor Fan—Type				
No. Used/Diameter in. [mm]	FC Centrifugal	FC Centrifugal	FC Centrifugal	FC Centrifugal
Drive Type/No. Speeds	1/11x12 [279.4x304.8]	1/11x12 [279.4x304.8]	1/11x12 [279.4x304.8]	1/11x12 [279.4x304.8]
No. Motors	Belt/Variable	Belt/Variable	Belt/Variable	Belt/Variable
Motor HP	1	1	1	1
Motor RPM	1 1/2	1 1/2	1 1/2	1 1/2
Motor Frame Size	1725	1725	1725	1725
	56	56	56	56
Filter—Type				
Furnished	Disposable	Disposable	Disposable	Disposable
(No.) Size Recommended in. [mm]	Yes	Yes	Yes	Yes
	(1)1x16x25 [25x406x635]	(1)1x16x25 [25x406x635]	(1)1x16x25 [25x406x635]	(1)1x16x25 [25x406x635]
	(1)1x16x25 [25x406x635]	(1)1x16x25 [25x406x635]	(1)1x16x25 [25x406x635]	(1)1x16x25 [25x406x635]
Refrigerant Charge Oz. [g]				
	176 [4990]	176 [4990]	176 [4990]	176 [4990]
Weights				
Net Weight lbs. [kg]	608 [276]	608 [276]	608 [276]	608 [276]
Ship Weight lbs. [kg]	615 [279]	615 [279]	615 [279]	615 [279]

CONTINUED →

See Page 37 for Notes.

[] Designates Metric Conversions



NOM. SIZES 3-7.5 TONS [10.6-26.4 kW] ASHRAE 90.1-1989 COMPLIANT MODELS

Model RKKA- Series	A073YL10E	A073YL13E	A073YM10E	A073YM13E
Cooling Performance¹				
Gross Cooling Capacity Btu [kW]	75,000 [22]	75,000 [22]	75,000 [22]	75,000 [22]
EER/SEER ²	9.8/NA	9.8/NA	9.8/NA	9.8/NA
Nominal CFM/ARI Rated CFM [L/s]	2400/2200 [1133/1038]	2400/2200 [1133/1038]	2400/2200 [1133/1038]	2400/2200 [1133/1038]
ARI Net Cooling Capacity Btu [kW]	72,000 [21.1]	72,000 [21.1]	72,000 [21.1]	72,000 [21.1]
Net Sensible Capacity Btu [kW]	51,500 [15.1]	51,500 [15.1]	51,500 [15.1]	51,500 [15.1]
Net Latent Capacity Btu [kW]	20,500 [6]	20,500 [6]	20,500 [6]	20,500 [6]
Integrated Part Load Value ³	NA	NA	NA	NA
Net System Power kW	7.3	7.3	7.3	7.3
Heating Performance (Package Gas/Electric)⁴				
Heating Input Btu [kW] (1st Stage / 2nd Stage)	100,000 [29.3]	135,000 [39.6]	100,000 [29.3]	135,000 [39.6]
Heating Output Btu [kW] (1st Stage / 2nd Stage)	81,000 [23.7]	109,400 [32.1]	81,000 [23.7]	109,400 [32.1]
Temperature Rise Range °F [°C]	20-50 [11.1/27.8]	30-60 [16.7/33.3]	20-50 [11.1/27.8]	30-60 [16.7/33.3]
AFUE %	80	80	80	80
Steady State Efficiency (%)	81	81	81	81
No. Burners	5	6	5	6
No. Stages	1	1	1	1
Gas Connection Pipe Size in. [mm]	0.5 [12.7]	0.5 [12.7]	0.5 [12.7]	0.5 [12.7]
Compressor				
No./Type	1/Scroll	1/Scroll	1/Scroll	1/Scroll
Outdoor Sound Rating (dB)⁵				
	83	83	83	83
Outdoor Coil—Fin Type				
Tube Type	Louvered	Louvered	Louvered	Louvered
Tube Size in. [mm] OD	Rifled	Rifled	Rifled	Rifled
Tube Size in. [mm] OD	0.375 [9.5]	0.375 [9.5]	0.375 [9.5]	0.375 [9.5]
Face Area sq. ft. [sq. m]	16.56 [1.54]	16.56 [1.54]	16.56 [1.54]	16.56 [1.54]
Rows / FPI [FPcm]	2 / 22 [9]	2 / 22 [9]	2 / 22 [9]	2 / 22 [9]
Indoor Coil—Fin Type				
Tube Type	Louvered	Louvered	Louvered	Louvered
Tube Type	Rifled	Rifled	Rifled	Rifled
Tube Size in. [mm]	0.3125 [7.9]	0.3125 [7.9]	0.3125 [7.9]	0.3125 [7.9]
Face Area sq. ft. [sq. m]	5.17 [0.48]	5.17 [0.48]	5.17 [0.48]	5.17 [0.48]
Rows / FPI [FPcm]	5 / 13 [5]	5 / 13 [5]	5 / 13 [5]	5 / 13 [5]
Refrigerant Control	TX Valves	TX Valves	TX Valves	TX Valves
Drain Connection No./Size in. [mm]	1/1 [25.4]	1/1 [25.4]	1/1 [25.4]	1/1 [25.4]
Outdoor Fan—Type				
Propeller	Propeller	Propeller	Propeller	Propeller
No. Used/Diameter in. [mm]	1/24 [609.6]	1/24 [609.6]	1/24 [609.6]	1/24 [609.6]
Drive Type/No. Speeds	Direct/1	Direct/1	Direct/1	Direct/1
CFM [L/s]	4000 [1888]	4000 [1888]	4000 [1888]	4000 [1888]
No. Motors/HP	1 at 1/3 HP	1 at 1/3 HP	1 at 1/3 HP	1 at 1/3 HP
Motor RPM	1075	1075	1075	1075
Indoor Fan—Type				
FC Centrifugal	FC Centrifugal	FC Centrifugal	FC Centrifugal	FC Centrifugal
No. Used/Diameter in. [mm]	1/11x12 [279.4x304.8]	1/11x12 [279.4x304.8]	1/11x12 [279.4x304.8]	1/11x12 [279.4x304.8]
Drive Type/No. Speeds	Belt/Variable	Belt/Variable	Belt/Variable	Belt/Variable
No. Motors	1	1	1	1
Motor HP	1 1/2	1 1/2	1 1/2	1 1/2
Motor RPM	1725	1725	1725	1725
Motor Frame Size	56	56	56	56
Filter—Type				
Disposable	Disposable	Disposable	Disposable	Disposable
Furnished	Yes	Yes	Yes	Yes
(No.) Size Recommended in. [mm]	(1)1x16x25 [25x406x635]	(1)1x16x25 [25x406x635]	(1)1x16x25 [25x406x635]	(1)1x16x25 [25x406x635]
	(1)1x16x25 [25x406x635]	(1)1x16x25 [25x406x635]	(1)1x16x25 [25x406x635]	(1)1x16x25 [25x406x635]
Refrigerant Charge Oz. (Sys. 1/Sys. 2) [g]				
	176 [4990]	176 [4990]	176 [4990]	176 [4990]
Weights				
Net Weight lbs. [kg]	608 [276]	608 [276]	608 [276]	608 [276]
Ship Weight lbs. [kg]	615 [279]	615 [279]	615 [279]	615 [279]

See Page 37 for Notes.

[] Designates Metric Conversions



NOM. SIZES 3-7.5 TONS [10.6-26.4 kW] ASHRAE 90.1-1989 COMPLIANT MODELS

Model RKKA- Series	A085CL13E	A085CL13T	A085CM13E	A085CM13T
Cooling Performance¹				
Gross Cooling Capacity Btu [kW]	90,000 [26.4]	90,000 [26.4]	90,000 [26.4]	90,000 [26.4]
EER/SEER ²	9.1/NA	9.1/NA	9.1/NA	9.1/NA
Nominal CFM/ARI Rated CFM [L/s]	2800/2850 [1321/1345]	2800/2850 [1321/1345]	2800/2850 [1321/1345]	2800/2850 [1321/1345]
ARI Net Cooling Capacity Btu [kW]	85,000 [24.9]	85,000 [24.9]	85,000 [24.9]	85,000 [24.9]
Net Sensible Capacity Btu [kW]	63,380 [18.6]	63,380 [18.6]	63,380 [18.6]	63,380 [18.6]
Net Latent Capacity Btu [kW]	21,620 [6.3]	21,620 [6.3]	21,620 [6.3]	21,620 [6.3]
Integrated Part Load Value ³	10	10	10	10
Net System Power kW	9.3	9.3	9.3	9.3
Heating Performance (Package Gas/Electric)⁴				
Heating Input Btu [kW] (1st Stage / 2nd Stage)	135,000 [39.6]	74,250/135,000 [21.8/39.6]	135,000 [39.6]	74,250/135,000 [21.8/39.6]
Heating Output Btu [kW] (1st Stage / 2nd Stage)	109,400 [32.1]	60,170/109,400 [17.6/32.1]	109,400 [32.1]	60,170/109,400 [17.6/32.1]
Temperature Rise Range °F [°C]	20-50 [11.1/27.8]	20-50 [11.1/27.8]	20-50 [11.1/27.8]	20-50 [11.1/27.8]
AFUE %	80	80	80	80
Steady State Efficiency (%)	81	81	81	81
No. Burners	6	6	6	6
No. Stages	1	2	1	2
Gas Connection Pipe Size in. [mm]	0.5 [12.7]	0.5 [12.7]	0.5 [12.7]	0.5 [12.7]
Compressor				
No./Type	2/Scroll	2/Scroll	2/Scroll	2/Scroll
Outdoor Sound Rating (dB)⁵				
	83	83	83	83
Outdoor Coil—Fin Type				
Tube Type	Louvered	Louvered	Louvered	Louvered
Tube Size in. [mm] OD	Rifled	Rifled	Rifled	Rifled
Face Area sq. ft. [sq. m]	0.375 [9.5]	0.375 [9.5]	0.375 [9.5]	0.375 [9.5]
Rows / FPI [FPcm]	16.56 [1.54]	16.56 [1.54]	16.56 [1.54]	16.56 [1.54]
	2 / 22 [9]	2 / 22 [9]	2 / 22 [9]	2 / 22 [9]
Indoor Coil—Fin Type				
Tube Type	Louvered	Louvered	Louvered	Louvered
Tube Size in. [mm]	Rifled	Rifled	Rifled	Rifled
Face Area sq. ft. [sq. m]	0.3125 [7.9]	0.3125 [7.9]	0.3125 [7.9]	0.3125 [7.9]
Rows / FPI [FPcm]	6.5 [0.6]	6.5 [0.6]	6.5 [0.6]	6.5 [0.6]
	5 / 12 [5]	5 / 12 [5]	5 / 12 [5]	5 / 12 [5]
Refrigerant Control	Capillary Tubes	Capillary Tubes	Capillary Tubes	Capillary Tubes
Drain Connection No./Size in. [mm]	1/1 [25.4]	1/1 [25.4]	1/1 [25.4]	1/1 [25.4]
Outdoor Fan—Type				
No. Used/Diameter in. [mm]	Propeller	Propeller	Propeller	Propeller
Drive Type/No. Speeds	1/24 [609.6]	1/24 [609.6]	1/24 [609.6]	1/24 [609.6]
CFM [L/s]	Direct/1	Direct/1	Direct/1	Direct/1
No. Motors/HP	4000 [1888]	4000 [1888]	4000 [1888]	4000 [1888]
Motor RPM	1 at 1/3 HP	1 at 1/3 HP	1 at 1/3 HP	1 at 1/3 HP
	1075	1075	1075	1075
Indoor Fan—Type				
No. Used/Diameter in. [mm]	FC Centrifugal	FC Centrifugal	FC Centrifugal	FC Centrifugal
Drive Type/No. Speeds	1/11x12 [279.4x304.8]	1/11x12 [279.4x304.8]	1/11x12 [279.4x304.8]	1/11x12 [279.4x304.8]
No. Motors	Belt/Variable	Belt/Variable	Belt/Variable	Belt/Variable
Motor HP	1	1	1	1
Motor RPM	1 1/2	1 1/2	1 1/2	1 1/2
Motor Frame Size	1725	1725	1725	1725
	56	56	56	56
Filter—Type				
Furnished	Disposable	Disposable	Disposable	Disposable
(No.) Size Recommended in. [mm]	Yes	Yes	Yes	Yes
	(2)2x16x16 [51x406x406]	(2)2x16x16 [51x406x406]	(2)2x16x16 [51x406x406]	(2)2x16x16 [51x406x406]
	(2)2x16x16 [51x406x406]	(2)2x16x16 [51x406x406]	(2)2x16x16 [51x406x406]	(2)2x16x16 [51x406x406]
Refrigerant Charge Oz. (Sys. 1/Sys. 2) [g]				
	192/192 [5443/5443]	192/192 [5443/5443]	192/192 [5443/5443]	192/192 [5443/5443]
Weights				
Net Weight lbs. [kg]	690 [313]	690 [313]	690 [313]	690 [313]
Ship Weight lbs. [kg]	699 [317]	699 [317]	699 [317]	699 [317]

CONTINUED →

See Page 37 for Notes.

[] Designates Metric Conversions



NOM. SIZES 3-7.5 TONS [10.6-26.4 kW] ASHRAE 90.1-1989 COMPLIANT MODELS

Model RKKA- Series	A085DL13E	A085DL13T	A085DM13E	A085DM13T
Cooling Performance¹				
Gross Cooling Capacity Btu [kW]	90,000 [26.4]	90,000 [26.4]	90,000 [26.4]	90,000 [26.4]
EER/SEER ²	9.1/NA	9.1/NA	9.1/NA	9.1/NA
Nominal CFM/ARI Rated CFM [L/s]	2800/2850 [1321/1345]	2800/2850 [1321/1345]	2800/2850 [1321/1345]	2800/2850 [1321/1345]
ARI Net Cooling Capacity Btu [kW]	85,000 [24.9]	85,000 [24.9]	85,000 [24.9]	85,000 [24.9]
Net Sensible Capacity Btu [kW]	63,380 [18.6]	63,380 [18.6]	63,380 [18.6]	63,380 [18.6]
Net Latent Capacity Btu [kW]	21,620 [6.3]	21,620 [6.3]	21,620 [6.3]	21,620 [6.3]
Integrated Part Load Value ³	10	10	10	10
Net System Power kW	9.3	9.3	9.3	9.3
Heating Performance (Package Gas/Electric)⁴				
Heating Input Btu [kW] (1st Stage / 2nd Stage)	135,000 [39.6]	74,250/135,000 [21.8/39.6]	135,000 [39.6]	74,250/135,000 [21.8/39.6]
Heating Output Btu [kW] (1st Stage / 2nd Stage)	109,400 [32.1]	60,170/109,400 [17.6/32.1]	109,400 [32.1]	60,170/109,400 [17.6/32.1]
Temperature Rise Range °F [°C]	20-50 [11.1/27.8]	20-50 [11.1/27.8]	20-50 [11.1/27.8]	20-50 [11.1/27.8]
AFUE %	80	80	80	80
Steady State Efficiency (%)	81	81	81	81
No. Burners	6	6	6	6
No. Stages	1	2	1	2
Gas Connection Pipe Size in. [mm]	0.5 [12.7]	0.5 [12.7]	0.5 [12.7]	0.5 [12.7]
Compressor				
No./Type	2/Scroll	2/Scroll	2/Scroll	2/Scroll
Outdoor Sound Rating (dB)⁵				
	83	83	83	83
Outdoor Coil—Fin Type				
Tube Type	Louvered	Louvered	Louvered	Louvered
Tube Size in. [mm] OD	Rifled	Rifled	Rifled	Rifled
Tube Size in. [mm] OD	0.375 [9.5]	0.375 [9.5]	0.375 [9.5]	0.375 [9.5]
Face Area sq. ft. [sq. m]	16.56 [1.54]	16.56 [1.54]	16.56 [1.54]	16.56 [1.54]
Rows / FPI [FPcm]	2 / 22 [9]	2 / 22 [9]	2 / 22 [9]	2 / 22 [9]
Indoor Coil—Fin Type				
Tube Type	Louvered	Louvered	Louvered	Louvered
Tube Type	Rifled	Rifled	Rifled	Rifled
Tube Size in. [mm]	0.3125 [7.9]	0.3125 [7.9]	0.3125 [7.9]	0.3125 [7.9]
Face Area sq. ft. [sq. m]	6.5 [0.6]	6.5 [0.6]	6.5 [0.6]	6.5 [0.6]
Rows / FPI [FPcm]	5 / 12 [5]	5 / 12 [5]	5 / 12 [5]	5 / 12 [5]
Refrigerant Control	Capillary Tubes	Capillary Tubes	Capillary Tubes	Capillary Tubes
Drain Connection No./Size in. [mm]	1/1 [25.4]	1/1 [25.4]	1/1 [25.4]	1/1 [25.4]
Outdoor Fan—Type				
Type	Propeller	Propeller	Propeller	Propeller
No. Used/Diameter in. [mm]	1/24 [609.6]	1/24 [609.6]	1/24 [609.6]	1/24 [609.6]
Drive Type/No. Speeds	Direct/1	Direct/1	Direct/1	Direct/1
CFM [L/s]	4000 [1888]	4000 [1888]	4000 [1888]	4000 [1888]
No. Motors/HP	1 at 1/3 HP	1 at 1/3 HP	1 at 1/3 HP	1 at 1/3 HP
Motor RPM	1075	1075	1075	1075
Indoor Fan—Type				
Type	FC Centrifugal	FC Centrifugal	FC Centrifugal	FC Centrifugal
No. Used/Diameter in. [mm]	1/11x12 [279.4x304.8]	1/11x12 [279.4x304.8]	1/11x12 [279.4x304.8]	1/11x12 [279.4x304.8]
Drive Type/No. Speeds	Belt/Variable	Belt/Variable	Belt/Variable	Belt/Variable
No. Motors	1	1	1	1
Motor HP	1 1/2	1 1/2	1 1/2	1 1/2
Motor RPM	1725	1725	1725	1725
Motor Frame Size	56	56	56	56
Filter—Type				
Type	Disposable	Disposable	Disposable	Disposable
Furnished	Yes	Yes	Yes	Yes
(No.) Size Recommended in. [mm]	(2)2x16x16 [51x406x406]	(2)2x16x16 [51x406x406]	(2)2x16x16 [51x406x406]	(2)2x16x16 [51x406x406]
	(2)2x16x16 [51x406x406]	(2)2x16x16 [51x406x406]	(2)2x16x16 [51x406x406]	(2)2x16x16 [51x406x406]
Refrigerant Charge Oz. (Sys. 1/Sys. 2) [g]				
	192/192 [5443/5443]	192/192 [5443/5443]	192/192 [5443/5443]	192/192 [5443/5443]
Weights				
Net Weight lbs. [kg]	690 [313]	690 [313]	690 [313]	690 [313]
Ship Weight lbs. [kg]	699 [317]	699 [317]	699 [317]	699 [317]

See Page 37 for Notes.

[] Designates Metric Conversions



NOM. SIZES 3-7.5 TONS [10.6-26.4 kW] ASHRAE 90.1-1989 COMPLIANT MODELS

Model RKKA- Series	A085YL13E	A085YL13T	A085YM13E	A085YM13T
Cooling Performance¹				
Gross Cooling Capacity Btu [kW]	90,000 [26.4]	90,000 [26.4]	90,000 [26.4]	90,000 [26.4]
EER/SEER ²	9.1/NA	9.1/NA	9.1/NA	9.1/NA
Nominal CFM/ARI Rated CFM [L/s]	2800/2850 [1321/1345]	2800/2850 [1321/1345]	2800/2850 [1321/1345]	2800/2850 [1321/1345]
ARI Net Cooling Capacity Btu [kW]	85,000 [24.9]	85,000 [24.9]	85,000 [24.9]	85,000 [24.9]
Net Sensible Capacity Btu [kW]	63,380 [18.6]	63,380 [18.6]	63,380 [18.6]	63,380 [18.6]
Net Latent Capacity Btu [kW]	21,620 [6.3]	21,620 [6.3]	21,620 [6.3]	21,620 [6.3]
Integrated Part Load Value ³	10	10	10	10
Net System Power kW	9.3	9.3	9.3	9.3
Heating Performance (Package Gas/Electric)⁴				
Heating Input Btu [kW] (1st Stage / 2nd Stage)	135,000 [39.6]	74,250/135,000 [21.8/39.6]	135,000 [39.6]	74,250/135,000 [21.8/39.6]
Heating Output Btu [kW] (1st Stage / 2nd Stage)	109,400 [32.1]	60,170/109,400 [17.6/32.1]	109,400 [32.1]	60,170/109,400 [17.6/32.1]
Temperature Rise Range °F [°C]	20-50 [11.1/27.8]	20-50 [11.1/27.8]	20-50 [11.1/27.8]	20-50 [11.1/27.8]
AFUE %	80	80	80	80
Steady State Efficiency (%)	81	81	81	81
No. Burners	6	6	6	6
No. Stages	1	2	1	2
Gas Connection Pipe Size in. [mm]	0.5 [12.7]	0.5 [12.7]	0.5 [12.7]	0.5 [12.7]
Compressor				
No./Type	2/Scroll	2/Scroll	2/Scroll	2/Scroll
Outdoor Sound Rating (dB)⁵				
	83	83	83	83
Outdoor Coil—Fin Type				
Tube Type	Louvered	Louvered	Louvered	Louvered
Tube Size in. [mm] OD	Rifled	Rifled	Rifled	Rifled
Face Area sq. ft. [sq. m]	0.375 [9.5]	0.375 [9.5]	0.375 [9.5]	0.375 [9.5]
Rows / FPI [FPcm]	16.56 [1.54]	16.56 [1.54]	16.56 [1.54]	16.56 [1.54]
	2 / 22 [9]	2 / 22 [9]	2 / 22 [9]	2 / 22 [9]
Indoor Coil—Fin Type				
Tube Type	Louvered	Louvered	Louvered	Louvered
Tube Size in. [mm]	Rifled	Rifled	Rifled	Rifled
Face Area sq. ft. [sq. m]	0.3125 [7.9]	0.3125 [7.9]	0.3125 [7.9]	0.3125 [7.9]
Rows / FPI [FPcm]	6.5 [0.6]	6.5 [0.6]	6.5 [0.6]	6.5 [0.6]
	5 / 12 [5]	5 / 12 [5]	5 / 12 [5]	5 / 12 [5]
Refrigerant Control	Capillary Tubes	Capillary Tubes	Capillary Tubes	Capillary Tubes
Drain Connection No./Size in. [mm]	1/1 [25.4]	1/1 [25.4]	1/1 [25.4]	1/1 [25.4]
Outdoor Fan—Type				
No. Used/Diameter in. [mm]	Propeller	Propeller	Propeller	Propeller
Drive Type/No. Speeds	1/24 [609.6]	1/24 [609.6]	1/24 [609.6]	1/24 [609.6]
CFM [L/s]	Direct/1	Direct/1	Direct/1	Direct/1
No. Motors/HP	4000 [1888]	4000 [1888]	4000 [1888]	4000 [1888]
Motor RPM	1 at 1/3 HP	1 at 1/3 HP	1 at 1/3 HP	1 at 1/3 HP
	1075	1075	1075	1075
Indoor Fan—Type				
No. Used/Diameter in. [mm]	FC Centrifugal	FC Centrifugal	FC Centrifugal	FC Centrifugal
Drive Type/No. Speeds	1/11x12 [279.4x304.8]	1/11x12 [279.4x304.8]	1/11x12 [279.4x304.8]	1/11x12 [279.4x304.8]
No. Motors	Belt/Variable	Belt/Variable	Belt/Variable	Belt/Variable
Motor HP	1	1	1	1
Motor RPM	1 1/2	1 1/2	1 1/2	1 1/2
Motor Frame Size	1725	1725	1725	1725
	56	56	56	56
Filter—Type				
Furnished	Disposable	Disposable	Disposable	Disposable
(No.) Size Recommended in. [mm]	Yes	Yes	Yes	Yes
	(2)2x16x16 [51x406x406]	(2)2x16x16 [51x406x406]	(2)2x16x16 [51x406x406]	(2)2x16x16 [51x406x406]
	(2)2x16x16 [51x406x406]	(2)2x16x16 [51x406x406]	(2)2x16x16 [51x406x406]	(2)2x16x16 [51x406x406]
Refrigerant Charge Oz. (Sys. 1/Sys. 2) [g]				
	192/192 [5443/5443]	192/192 [5443/5443]	192/192 [5443/5443]	192/192 [5443/5443]
Weights				
Net Weight lbs. [kg]	690 [313]	690 [313]	690 [313]	690 [313]
Ship Weight lbs. [kg]	699 [317]	699 [317]	699 [317]	699 [317]

See Page 37 for Notes.

[] Designates Metric Conversions



NOM. SIZES 6 TON [21.1 kW] ASHRAE 90.1-1999 COMPLIANT MODELS

Model RKMA- Series	A072CL10E	A072CL13E	A072CM10E	A072CM13E
Cooling Performance¹				
Gross Cooling Capacity Btu [kW]	75,000 [22]	75,000 [22]	75,000 [22]	75,000 [22]
EER/SEER ²	10.3/NA	10.3/NA	10.3/NA	10.3/NA
Nominal CFM/ARI Rated CFM [L/s]	2400/2400 [1133/1133]	2400/2400 [1133/1133]	2400/2400 [1133/1133]	2400/2400 [1133/1133]
ARI Net Cooling Capacity Btu [kW]	72,000 [21.1]	72,000 [21.1]	72,000 [21.1]	72,000 [21.1]
Net Sensible Capacity Btu [kW]	53,000 [15.5]	53,000 [15.5]	53,000 [15.5]	53,000 [15.5]
Net Latent Capacity Btu [kW]	19,000 [5.6]	19,000 [5.6]	19,000 [5.6]	19,000 [5.6]
Integrated Part Load Value ³	11.5	11.5	11.5	11.5
Net System Power kW	7	7	7	7
Heating Performance (Package Gas/Electric)⁴				
Heating Input Btu [kW]	100,000 [29.3]	135,000 [39.6]	100,000 [29.3]	135,000 [39.6]
Heating Output Btu [kW]	81,000 [23.7]	109,400 [32.1]	81,000 [23.7]	109,400 [32.1]
Temperature Rise Range °F [°C]	20-50 [11.1/27.8]	30-60 [16.7/33.3]	20-50 [11.1/27.8]	30-60 [16.7/33.3]
AFUE %	80	80	80	80
Steady State Efficiency (%)	81	81	81	81
No. Burners	5	6	5	6
No. Stages	1	1	1	1
Gas Connection Pipe Size in. [mm]	0.5 [12.7]	0.5 [12.7]	0.5 [12.7]	0.5 [12.7]
Compressor				
No./Type	2/Scroll	2/Scroll	2/Scroll	2/Scroll
Outdoor Sound Rating (dB)⁵				
	83	83	83	83
Outdoor Coil—Fin Type				
Tube Type	Louvered	Louvered	Louvered	Louvered
Tube Size in. [mm] OD	Rifled	Rifled	Rifled	Rifled
Tube Size in. [mm] OD	0.375 [9.5]	0.375 [9.5]	0.375 [9.5]	0.375 [9.5]
Face Area sq. ft. [sq. m]	16.56 [1.54]	16.56 [1.54]	16.56 [1.54]	16.56 [1.54]
Rows / FPI [FPcm]	2 / 22 [9]	2 / 22 [9]	2 / 22 [9]	2 / 22 [9]
Indoor Coil—Fin Type				
Tube Type	Louvered	Louvered	Louvered	Louvered
Tube Type	Rifled	Rifled	Rifled	Rifled
Tube Size in. [mm]	0.375 [9.5]	0.375 [9.5]	0.375 [9.5]	0.375 [9.5]
Face Area sq. ft. [sq. m]	6.5 [0.6]	6.5 [0.6]	6.5 [0.6]	6.5 [0.6]
Rows / FPI [FPcm]	4 / 12 [5]	4 / 12 [5]	4 / 12 [5]	4 / 12 [5]
Refrigerant Control	Capillary Tubes	Capillary Tubes	Capillary Tubes	Capillary Tubes
Drain Connection No./Size in. [mm]	1/1 [25.4]	1/1 [25.4]	1/1 [25.4]	1/1 [25.4]
Outdoor Fan—Type				
Propeller	Propeller	Propeller	Propeller	Propeller
No. Used/Diameter in. [mm]	1/24 [609.6]	1/24 [609.6]	1/24 [609.6]	1/24 [609.6]
Drive Type/No. Speeds	Direct/1	Direct/1	Direct/1	Direct/1
CFM [L/s]	4000 [1888]	4000 [1888]	4000 [1888]	4000 [1888]
No. Motors/HP	1 at 1/3 HP	1 at 1/3 HP	1 at 1/3 HP	1 at 1/3 HP
Motor RPM	1075	1075	1075	1075
Indoor Fan—Type				
FC Centrifugal	FC Centrifugal	FC Centrifugal	FC Centrifugal	FC Centrifugal
No. Used/Diameter in. [mm]	1/11x12[279.4x304.8]	1/11x12[279.4x304.8]	1/11x12[279.4x304.8]	1/11x12[279.4x304.8]
Drive Type/No. Speeds	Belt/Variable	Belt/Variable	Belt/Variable	Belt/Variable
No. Motors	1	1	1	1
Motor HP	1 1/2	1 1/2	1 1/2	1 1/2
Motor RPM	1725	1725	1725	1725
Motor Frame Size	56	56	56	56
Filter—Type				
Disposable	Disposable	Disposable	Disposable	Disposable
Furnished	Yes	Yes	Yes	Yes
(No.) Size Recommended in. [mm]	(4)2x16x16 [51x406x406]	(4)2x16x16 [51x406x406]	(4)2x16x16 [51x406x406]	(4)2x16x16 [51x406x406]
Refrigerant Charge Oz. (Sys. 1/Sys. 2) [g]				
	88/88 [2495/2495]	88/88 [2495/2495]	88/88 [2495/2495]	88/88 [2495/2495]
Weights				
Net Weight lbs. [kg]	608 [276]	608 [276]	615 [279]	615 [279]
Ship Weight lbs. [kg]	615 [279]	615 [279]	608 [276]	608 [276]

See Page 37 for Notes.

[] Designates Metric Conversions



NOM. SIZES 6 TON [21.1 kW] ASHRAE 90.1-1999 COMPLIANT MODELS

Model RKMA- Series	A072DL10E	A072DL13E	A072DM10E	A072DM13E
Cooling Performance¹				CONTINUED →
Gross Cooling Capacity Btu [kW]	75,000 [22]	75,000 [22]	75,000 [22]	75,000 [22]
EER/SEER ²	10.3/NA	10.3/NA	10.3/NA	10.3/NA
Nominal CFM/ARI Rated CFM [L/s]	2400/2400 [1133/1133]	2400/2400 [1133/1133]	2400/2400 [1133/1133]	2400/2400 [1133/1133]
ARI Net Cooling Capacity Btu [kW]	72,000 [21.1]	72,000 [21.1]	72,000 [21.1]	72,000 [21.1]
Net Sensible Capacity Btu [kW]	53,000 [15.5]	53,000 [15.5]	53,000 [15.5]	53,000 [15.5]
Net Latent Capacity Btu [kW]	19,000 [5.6]	19,000 [5.6]	19,000 [5.6]	19,000 [5.6]
Integrated Part Load Value ³	11.5	11.5	11.5	11.5
Net System Power kW	7	7	7	7
Heating Performance (Package Gas/Electric)⁴				
Heating Input Btu [kW]	100,000 [29.3]	135,000 [39.6]	100,000 [29.3]	135,000 [39.6]
Heating Output Btu [kW]	81,000 [23.7]	109,400 [32.1]	81,000 [23.7]	109,400 [32.1]
Temperature Rise Range °F [°C]	20-50 [11.1/27.8]	30-60 [16.7/33.3]	20-50 [11.1/27.8]	30-60 [16.7/33.3]
AFUE %	80	80	80	80
Steady State Efficiency (%)	81	81	81	81
No. Burners	5	6	5	6
No. Stages	1	1	1	1
Gas Connection Pipe Size in. [mm]	0.5 [12.7]	0.5 [12.7]	0.5 [12.7]	0.5 [12.7]
Compressor				
No./Type	2/Scroll	2/Scroll	2/Scroll	2/Scroll
Outdoor Sound Rating (dB)⁵				
	83	83	83	83
Outdoor Coil—Fin Type				
Tube Type	Louvered	Louvered	Louvered	Louvered
Tube Size in. [mm] OD	Rifled	Rifled	Rifled	Rifled
Face Area sq. ft. [sq. m]	0.375 [9.5]	0.375 [9.5]	0.375 [9.5]	0.375 [9.5]
Rows / FPI [FPcm]	16.56 [1.54]	16.56 [1.54]	16.56 [1.54]	16.56 [1.54]
	2 / 22 [9]	2 / 22 [9]	2 / 22 [9]	2 / 22 [9]
Indoor Coil—Fin Type				
Tube Type	Louvered	Louvered	Louvered	Louvered
Tube Size in. [mm]	Rifled	Rifled	Rifled	Rifled
Face Area sq. ft. [sq. m]	0.375 [9.5]	0.375 [9.5]	0.375 [9.5]	0.375 [9.5]
Rows / FPI [FPcm]	6.5 [0.6]	6.5 [0.6]	6.5 [0.6]	6.5 [0.6]
	4 / 12 [5]	4 / 12 [5]	4 / 12 [5]	4 / 12 [5]
Refrigerant Control	Capillary Tubes	Capillary Tubes	Capillary Tubes	Capillary Tubes
Drain Connection No./Size in. [mm]	1/1 [25.4]	1/1 [25.4]	1/1 [25.4]	1/1 [25.4]
Outdoor Fan—Type				
No. Used/Diameter in. [mm]	Propeller	Propeller	Propeller	Propeller
Drive Type/No. Speeds	1/24 [609.6]	1/24 [609.6]	1/24 [609.6]	1/24 [609.6]
CFM [L/s]	Direct/1	Direct/1	Direct/1	Direct/1
No. Motors/HP	4000 [1888]	4000 [1888]	4000 [1888]	4000 [1888]
Motor RPM	1 at 1/3 HP	1 at 1/3 HP	1 at 1/3 HP	1 at 1/3 HP
	1075	1075	1075	1075
Indoor Fan—Type				
No. Used/Diameter in. [mm]	FC Centrifugal	FC Centrifugal	FC Centrifugal	FC Centrifugal
Drive Type/No. Speeds	1/11x12[279.4x304.8]	1/11x12[279.4x304.8]	1/11x12[279.4x304.8]	1/11x12[279.4x304.8]
No. Motors	Belt/Variable	Belt/Variable	Belt/Variable	Belt/Variable
Motor HP	1	1	1	1
Motor RPM	1 1/2	1 1/2	1 1/2	1 1/2
Motor Frame Size	1725	1725	1725	1725
	56	56	56	56
Filter—Type				
Furnished	Disposable	Disposable	Disposable	Disposable
(No.) Size Recommended in. [mm]	Yes	Yes	Yes	Yes
	(4)2x16x16 [51x406x406]	(4)2x16x16 [51x406x406]	(4)2x16x16 [51x406x406]	(4)2x16x16 [51x406x406]
Refrigerant Charge Oz. (Sys. 1/Sys. 2) [g]				
	88/88 [2495/2495]	88/88 [2495/2495]	88/88 [2495/2495]	88/88 [2495/2495]
Weights				
Net Weight lbs. [kg]	608 [276]	608 [276]	608 [276]	608 [276]
Ship Weight lbs. [kg]	615 [279]	615 [279]	615 [279]	615 [279]

See Page 37 for Notes.

[] Designates Metric Conversions



NOM. SIZES 6 TON [21.1 kW] ASHRAE 90.1-1999 COMPLIANT MODELS

Model RKMA- Series	A072YL10E	A072YL13E	A072YM10E	A072YM13E
Cooling Performance¹				
Gross Cooling Capacity Btu [kW]	75,000 [22]	75,000 [22]	75,000 [22]	75,000 [22]
EER/SEER ²	10.3/NA	10.3/NA	10.3/NA	10.3/NA
Nominal CFM/ARI Rated CFM [L/s]	2400/2400 [1133/1133]	2400/2400 [1133/1133]	2400/2400 [1133/1133]	2400/2400 [1133/1133]
ARI Net Cooling Capacity Btu [kW]	72,000 [21.1]	72,000 [21.1]	72,000 [21.1]	72,000 [21.1]
Net Sensible Capacity Btu [kW]	53,000 [15.5]	53,000 [15.5]	53,000 [15.5]	53,000 [15.5]
Net Latent Capacity Btu [kW]	19,000 [5.6]	19,000 [5.6]	19,000 [5.6]	19,000 [5.6]
Integrated Part Load Value ³	11.5	11.5	11.5	11.5
Net System Power kW	7	7	7	7
Heating Performance (Package Gas/Electric)⁴				
Heating Input Btu [kW] (1st Stage / 2nd Stage)	100,000 [29.3]	135,000 [39.6]	100,000 [29.3]	135,000 [39.6]
Heating Output Btu [kW] (1st Stage / 2nd Stage)	81,000 [23.7]	109,400 [32.1]	81,000 [23.7]	109,400 [32.1]
Temperature Rise Range °F [°C]	20-50 [11.1/27.8]	30-60 [16.7/33.3]	20-50 [11.1/27.8]	30-60 [16.7/33.3]
AFUE %	80	80	80	80
Steady State Efficiency (%)	81	81	81	81
No. Burners	5	6	5	6
No. Stages	1	1	1	1
Gas Connection Pipe Size in. [mm]	0.5 [12.7]	0.5 [12.7]	0.5 [12.7]	0.5 [12.7]
Compressor				
No./Type	2/Scroll	2/Scroll	2/Scroll	2/Scroll
Outdoor Sound Rating (dB)⁵				
	83	83	83	83
Outdoor Coil—Fin Type				
Tube Type	Louvered	Louvered	Louvered	Louvered
Tube Size in. [mm] OD	Rifled	Rifled	Rifled	Rifled
Tube Size in. [mm] OD	0.375 [9.5]	0.375 [9.5]	0.375 [9.5]	0.375 [9.5]
Face Area sq. ft. [sq. m]	16.56 [1.54]	16.56 [1.54]	16.56 [1.54]	16.56 [1.54]
Rows / FPI [FPcm]	2 / 22 [9]	2 / 22 [9]	2 / 22 [9]	2 / 22 [9]
Indoor Coil—Fin Type				
Tube Type	Louvered	Louvered	Louvered	Louvered
Tube Type	Rifled	Rifled	Rifled	Rifled
Tube Size in. [mm]	0.375 [9.5]	0.375 [9.5]	0.375 [9.5]	0.375 [9.5]
Face Area sq. ft. [sq. m]	6.5 [0.6]	6.5 [0.6]	6.5 [0.6]	6.5 [0.6]
Rows / FPI [FPcm]	4 / 12 [5]	4 / 12 [5]	4 / 12 [5]	4 / 12 [5]
Refrigerant Control	Capillary Tubes	Capillary Tubes	Capillary Tubes	Capillary Tubes
Drain Connection No./Size in. [mm]	1/1 [25.4]	1/1 [25.4]	1/1 [25.4]	1/1 [25.4]
Outdoor Fan—Type				
Propeller	Propeller	Propeller	Propeller	Propeller
No. Used/Diameter in. [mm]	1/24 [609.6]	1/24 [609.6]	1/24 [609.6]	1/24 [609.6]
Drive Type/No. Speeds	Direct/1	Direct/1	Direct/1	Direct/1
CFM [L/s]	4000 [1888]	4000 [1888]	4000 [1888]	4000 [1888]
No. Motors/HP	1 at 1/3 HP	1 at 1/3 HP	1 at 1/3 HP	1 at 1/3 HP
Motor RPM	1075	1075	1075	1075
Indoor Fan—Type				
FC Centrifugal	FC Centrifugal	FC Centrifugal	FC Centrifugal	FC Centrifugal
No. Used/Diameter in. [mm]	1/11x12[279.4x304.8]	1/11x12[279.4x304.8]	1/11x12[279.4x304.8]	1/11x12[279.4x304.8]
Drive Type/No. Speeds	Belt/Variable	Belt/Variable	Belt/Variable	Belt/Variable
No. Motors	1	1	1	1
Motor HP	1 1/2	1 1/2	1 1/2	1 1/2
Motor RPM	1725	1725	1725	1725
Motor Frame Size	56	56	56	56
Filter—Type				
Disposable	Disposable	Disposable	Disposable	Disposable
Furnished	Yes	Yes	Yes	Yes
(No.) Size Recommended in. [mm]	(4)2x16x16 [51x406x406]	(4)2x16x16 [51x406x406]	(4)2x16x16 [51x406x406]	(4)2x16x16 [51x406x406]
Refrigerant Charge Oz. (Sys. 1/Sys. 2) [g]				
	88/88 [2495/2495]	88/88 [2495/2495]	88/88 [2495/2495]	88/88 [2495/2495]
Weights				
Net Weight lbs. [kg]	608 [276]	608 [276]	608 [276]	608 [276]
Ship Weight lbs. [kg]	615 [279]	615 [279]	615 [279]	615 [279]

See Page 37 for Notes.

[] Designates Metric Conversions

NOTES:

1. Cooling Performance is rated at 95° F ambient, 80° F entering dry bulb, 67° F entering wet bulb. Gross capacity does not include the effect of fan motor heat. ARI capacity is net and includes the effect of fan motor heat. Units are suitable for operation to $\pm 20\%$ of nominal cfm. Units are certified in accordance with the Unitary Air Conditioner Equipment certification program, which is based on ARI Standard 210/240 or 360.
2. EER and/or SEER are rated at ARI conditions and in accordance with DOE test procedures.
3. Integrated Part Load Value is rated in accordance with ARI Standard 210/240 or 360. Units are rated at 80° F ambient, 80° F entering dry bulb, and 67° F entering wet bulb at ARI rated cfm.
4. Heating Performance limit settings and rating data were established and approved under laboratory test conditions using American National Standard Institute standards. Ratings shown are for elevations up to 2000 feet. For elevations above 2000 feet, ratings should be reduced at the rate of 4% for each 1000 feet above sea level.
5. Outdoor Sound Rating shown is tested in accordance with ARI Standard 270.



GROSS SYSTEMS PERFORMANCE DATA—A036

		ENTERING INDOOR AIR @ 80°F [26.7°C] dbE ①									
wbE		71°F [21.7°C]			67°F [19.4°C]			63°F [17.2°C]			
CFM [L/s]		1500 [707.9]	1200 [566.3]	900 [424.8]	1500 [707.9]	1200 [566.3]	900 [424.8]	1500 [707.9]	1200 [566.3]	900 [424.8]	
DR ①		.18	.15	.10	.18	.15	.10	.18	.15	.10	
OUTDOOR DRY BULB TEMPERATURE °F [°C]	75 [23.9]	Total BTUH [kW] Sens BTUH [kW] Power	43.4 [12.72] 28.2 [8.26] 2.9	41.7 [12.22] 24.9 [7.30] 2.9	40.0 [11.72] 21.7 [6.36] 2.8	41.6 [12.19] 33.0 [9.67] 2.9	39.9 [11.69] 29.8 [8.73] 2.8	38.2 [11.20] 26.5 [7.77] 2.8	39.8 [11.66] 38.0 [11.14] 2.9	38.1 [11.17] 34.7 [10.17] 2.8	36.4 [10.67] 31.5 [9.23] 2.7
	80 [26.7]	Total BTUH [kW] Sens BTUH [kW] Power	42.9 [12.57] 27.7 [8.12] 3.1	41.2 [12.07] 24.5 [2.10] 3.0	39.5 [11.58] 21.2 [6.21] 3.0	41.1 [12.05] 32.6 [9.55] 3.1	39.4 [11.55] 29.3 [8.59] 3.0	37.7 [11.05] 26.0 [7.62] 2.9	39.3 [11.52] 37.5 [10.99] 3.1	37.6 [11.02] 34.2 [10.02] 3.0	35.9 [10.52] 31.0 [9.09] 2.9
	85 [29.4]	Total BTUH [kW] Sens BTUH [kW] Power	42.3 [12.40] 27.3 [8.00] 3.3	40.6 [11.90] 24.0 [7.03] 3.2	38.9 [11.40] 20.8 [6.10] 3.1	40.6 [11.90] 32.1 [9.41] 3.3	38.9 [11.40] 28.9 [8.47] 3.2	37.2 [10.90] 25.6 [7.50] 3.1	38.8 [11.37] 37.1 [10.87] 3.2	37.1 [10.87] 33.8 [9.91] 3.1	35.4 [10.37] 30.5 [8.94] 3.1
	90 [32.2]	Total BTUH [kW] Sens BTUH [kW] Power	41.7 [12.22] 26.9 [7.88] 3.4	40.0 [11.72] 23.6 [6.92] 3.4	38.3 [11.22] 20.3 [5.95] 3.3	40.0 [11.72] 31.7 [9.29] 3.4	38.3 [11.22] 28.5 [8.35] 3.4	36.6 [10.73] 25.2 [7.39] 3.3	38.1 [11.17] 36.7 [10.76] 3.4	36.4 [10.67] 33.4 [9.79] 3.3	34.7 [10.17] 30.1 [8.82] 3.2
	95 [35]	Total BTUH [kW] Sens BTUH [kW] Power	41.0 [12.02] 26.5 [7.77] 3.6	39.3 [11.52] 23.2 [6.80] 3.5	37.6 [11.02] 20.0 [5.86] 3.5	39.3 [11.52] 31.3 [9.17] 3.6	37.6 [11.02] 28.1 [8.24] 3.5	35.8 [10.49] 24.8 [7.27] 3.5	37.4 [10.96] 36.3 [10.64] 3.6	35.7 [10.46] 33.0 [9.67] 3.5	34.0 [9.96] 29.7 [8.70] 3.4
	100 [37.8]	Total BTUH [kW] Sens BTUH [kW] Power	40.2 [11.78] 26.1 [7.65] 3.8	38.5 [11.28] 22.8 [6.68] 3.7	36.8 [10.78] 19.5 [5.71] 3.6	38.4 [11.25] 30.9 [9.06] 3.8	36.7 [10.76] 27.6 [8.09] 3.7	35.0 [10.26] 24.4 [7.15] 3.6	36.6 [10.73] 35.9 [10.52] 3.7	34.9 [10.23] 32.6 [9.55] 3.7	33.2 [9.73] 29.3 [8.59] 3.6
	105 [40.6]	Total BTUH [kW] Sens BTUH [kW] Power	39.2 [11.49] 25.7 [7.53] 4.0	37.5 [10.99] 22.4 [6.56] 3.9	35.8 [10.49] 19.1 [5.60] 3.8	37.5 [10.99] 30.5 [8.94] 3.9	35.8 [10.49] 27.2 [7.97] 3.9	34.0 [9.96] 24.0 [7.03] 3.8	35.6 [10.43] 35.4 [10.37] 3.9	33.9 [9.94] 32.2 [9.44] 3.8	32.2 [9.44] 28.9 [8.47] 3.8
	110 [43.3]	Total BTUH [kW] Sens BTUH [kW] Power	38.1 [11.17] 25.2 [7.39] 4.1	36.4 [10.67] 21.9 [6.42] 4.0	34.7 [10.17] 18.7 [5.48] 4.0	36.3 [10.64] 30.0 [8.79] 4.1	34.6 [10.14] 26.8 [7.85] 4.0	32.9 [9.64] 23.5 [6.89] 4.0	34.5 [10.11] 34.5 [10.11] 4.1	32.8 [9.61] 31.7 [9.29] 4.0	31.1 [9.11] 28.4 [8.32] 3.9
	115 [46.1]	Total BTUH [kW] Sens BTUH [kW] Power	36.8 [10.78] 24.7 [7.24] 4.3	35.1 [10.29] 21.4 [6.27] 4.2	33.4 [9.79] 18.1 [5.30] 4.1	35.0 [10.26] 29.5 [8.65] 4.3	33.3 [9.76] 26.2 [7.68] 4.2	31.6 [9.26] 23.0 [6.74] 4.1	33.2 [9.73] 33.2 [9.73] 4.2	31.5 [9.23] 31.2 [9.14] 4.2	29.8 [8.73] 27.9 [8.18] 4.1

GROSS SYSTEMS PERFORMANCE DATA—A042

		ENTERING INDOOR AIR @ 80°F [26.7°C] dbE ①									
wbE		71°F [21.7°C]			67°F [19.4°C]			63°F [17.2°C]			
CFM [L/s]		1750 [825.9]	1400 [660.7]	1050 [495.5]	1750 [825.9]	1400 [660.7]	1050 [495.5]	1750 [825.9]	1400 [660.7]	1050 [495.5]	
DR ①		.13	.09	.03	.13	.09	.03	.13	.09	.03	
OUTDOOR DRY BULB TEMPERATURE °F [°C]	75 [23.9]	Total BTUH [kW] Sens BTUH [kW] Power	49.5 [14.51] 34.5 [10.11] 3.5	47.5 [13.92] 30.6 [8.97] 3.4	45.6 [13.36] 26.6 [7.80] 3.3	48.0 [14.07] 39.5 [11.58] 3.5	46.0 [13.48] 35.6 [10.43] 3.4	44.0 [12.90] 31.6 [9.26] 3.4	45.4 [13.31] 45.4 [13.31] 3.4	43.4 [12.72] 41.9 [12.28] 3.3	41.5 [12.16] 37.9 [11.11] 3.3
	80 [26.7]	Total BTUH [kW] Sens BTUH [kW] Power	49.1 [14.39] 34.1 [9.99] 3.8	47.1 [13.80] 30.2 [8.85] 3.7	45.1 [13.22] 26.2 [7.68] 3.6	47.6 [13.95] 39.1 [11.46] 3.8	45.6 [13.36] 35.1 [10.29] 3.7	43.6 [12.78] 31.2 [9.14] 3.6	45.0 [13.19] 45.0 [13.19] 3.7	43.0 [12.60] 41.5 [12.16] 3.6	41.0 [12.02] 37.5 [10.99] 3.5
	85 [29.4]	Total BTUH [kW] Sens BTUH [kW] Power	48.6 [14.24] 33.7 [9.88] 4.0	46.6 [13.66] 29.8 [8.73] 3.9	44.6 [13.07] 25.8 [7.56] 3.8	47.1 [13.80] 38.7 [11.34] 4.0	45.1 [13.22] 34.7 [10.17] 3.9	43.1 [12.63] 30.8 [9.03] 3.8	44.5 [13.04] 44.5 [13.04] 3.9	42.5 [12.46] 41.0 [12.02] 3.8	40.5 [11.87] 37.1 [10.87] 3.7
	90 [32.2]	Total BTUH [kW] Sens BTUH [kW] Power	48.1 [14.10] 33.3 [9.76] 4.2	46.1 [13.51] 29.3 [8.59] 4.1	44.1 [12.92] 25.4 [7.44] 4.0	46.5 [13.63] 38.3 [11.22] 4.2	44.5 [13.04] 34.3 [10.05] 4.1	42.6 [12.48] 30.4 [8.91] 4.1	44.0 [12.90] 44.0 [12.90] 4.1	42.0 [12.31] 40.6 [11.90] 4.0	40.0 [11.72] 36.7 [10.76] 4.0
	95 [35]	Total BTUH [kW] Sens BTUH [kW] Power	47.4 [13.89] 32.9 [9.64] 4.5	45.4 [13.31] 28.9 [8.47] 4.4	43.4 [12.72] 25.0 [7.33] 4.3	45.8 [13.42] 37.8 [11.08] 4.5	43.9 [12.87] 33.9 [9.94] 4.4	41.9 [12.28] 29.9 [8.76] 4.3	43.3 [12.69] 43.3 [12.69] 4.4	41.3 [12.10] 40.2 [11.78] 4.3	39.3 [11.52] 36.2 [10.61] 4.2
	100 [37.8]	Total BTUH [kW] Sens BTUH [kW] Power	46.5 [13.63] 32.3 [9.47] 4.7	44.5 [13.04] 28.4 [8.32] 4.6	42.5 [12.46] 24.4 [7.15] 4.5	44.9 [13.16] 37.3 [10.93] 4.7	42.9 [12.57] 33.3 [9.76] 4.6	40.9 [11.99] 29.4 [8.62] 4.5	42.4 [12.43] 42.4 [12.43] 4.6	40.4 [11.84] 39.7 [11.63] 4.5	38.4 [11.25] 35.7 [10.46] 4.4
	105 [40.6]	Total BTUH [kW] Sens BTUH [kW] Power	45.3 [13.28] 31.7 [9.29] 4.9	43.3 [12.69] 27.8 [8.15] 4.8	41.3 [12.10] 23.8 [6.98] 4.7	43.7 [12.81] 36.7 [10.76] 4.9	41.7 [12.22] 32.7 [9.58] 4.8	39.7 [11.63] 28.8 [8.44] 4.8	41.2 [12.07] 41.2 [12.07] 4.8	39.2 [11.49] 39.1 [11.46] 4.7	37.2 [10.90] 35.1 [10.29] 4.7
	110 [43.3]	Total BTUH [kW] Sens BTUH [kW] Power	43.7 [12.81] 31.0 [9.09] 5.2	41.7 [12.22] 27.0 [7.91] 5.1	39.7 [11.63] 23.1 [6.77] 5.0	42.2 [12.37] 35.9 [10.52] 5.2	40.2 [11.78] 32.0 [9.38] 5.1	38.2 [11.19] 28.0 [8.21] 5.0	39.6 [11.61] 39.6 [11.61] 5.1	37.6 [11.02] 37.6 [11.02] 5.0	35.6 [10.43] 34.3 [10.05] 4.9
	115 [46.1]	Total BTUH [kW] Sens BTUH [kW] Power	41.7 [12.22] 30.0 [8.79] 5.4	39.7 [11.63] 26.1 [7.65] 5.3	37.7 [11.05] 22.1 [6.48] 5.2	40.2 [11.78] 35.0 [10.26] 5.4	38.2 [11.20] 31.0 [9.09] 5.3	36.2 [10.61] 27.1 [7.94] 5.2	37.6 [11.02] 37.6 [11.02] 5.3	35.6 [10.43] 35.6 [10.43] 5.2	33.6 [9.85] 33.4 [9.79] 5.1

DR —Depression ratio
dbE—Entering air dry bulb
wbE—Entering air wet bulb

Total —Total capacity x 1000 BTUH
Sens —Sensible capacity x 1000 BTUH
Power—KW input

NOTES: ① When the entering air dry bulb is other than 80°F [27°C], adjust the sensible capacity from the table by adding $[1.10 \times \text{CFM} \times (1 - \text{DR}) \times (\text{dbE} - 80)]$.

[] Designates Metric Conversions



GROSS SYSTEMS PERFORMANCE DATA—A048

Table with columns for entering indoor air conditions (71°F, 67°F, 63°F) and rows for outdoor dry bulb temperature (75°F to 115°F). Includes metrics for Total BTUH, Sens BTUH, and Power.

GROSS SYSTEMS PERFORMANCE DATA—A060

Table with columns for entering indoor air conditions (71°F, 67°F, 63°F) and rows for outdoor dry bulb temperature (75°F to 115°F). Includes metrics for Total BTUH, Sens BTUH, and Power.

DR —Depression ratio
dbE—Entering air dry bulb
wbE—Entering air wet bulb

Total —Total capacity x 1000 BTUH
Sens —Sensible capacity x 1000 BTUH
Power—KW input

NOTES: ① When the entering air dry bulb is other than 80°F [27°C], adjust the sensible capacity from the table by adding [(1.10 x CFM x (1 - DR) x (dbE - 80))].

[] Designates Metric Conversions



GROSS SYSTEMS PERFORMANCE DATA—A073

		ENTERING INDOOR AIR @ 80°F [26.7°C]									
wbE		71°F [21.7°C]			67°F [19.4°C]			63°F [17.2°C]			
CFM [L/s]		3000 [1415.8]	2400 [1132.7]	1800 [849.5]	3000 [1415.8]	2400 [1132.7]	1800 [849.5]	3000 [1415.8]	2400 [1132.7]	1800 [849.5]	
DR ①		.24	.21	.18	.24	.21	.18	.24	.21	.18	
OUTDOOR DRY BULB TEMPERATURE °F [°C]	75 [23.9]	Total BTUH [kW] Sens BTUH [kW] Power	84.7 [24.82] 52.0 [15.24] 5.2	81.3 [23.83] 45.7 [13.39] 5.1	77.8 [22.80] 39.4 [11.55] 5.0	81.6 [23.91] 61.5 [18.02] 5.2	78.2 [22.92] 55.3 [16.21] 5.1	74.8 [21.92] 49.0 [14.36] 4.9	76.2 [22.33] 69.5 [20.37] 5.1	72.7 [21.31] 63.2 [18.52] 4.9	69.3 [20.31] 56.9 [16.68] 4.8
	80 [26.7]	Total BTUH [kW] Sens BTUH [kW] Power	84.2 [24.68] 51.7 [15.15] 5.6	80.8 [23.68] 45.4 [13.31] 5.4	77.4 [22.68] 39.1 [11.46] 5.3	81.2 [23.80] 61.2 [17.94] 5.5	77.7 [22.77] 54.9 [16.09] 5.4	74.3 [21.78] 48.6 [14.24] 5.2	75.7 [22.19] 69.2 [20.28] 5.4	72.3 [21.19] 62.9 [18.43] 5.3	68.8 [20.16] 56.6 [16.59] 5.1
	85 [29.4]	Total BTUH [kW] Sens BTUH [kW] Power	83.7 [24.53] 51.4 [15.06] 5.9	80.3 [23.53] 45.1 [13.22] 5.7	76.8 [22.51] 38.8 [11.37] 5.6	80.6 [23.62] 60.9 [17.85] 5.8	77.2 [22.63] 54.6 [16.00] 5.7	73.8 [21.63] 48.4 [14.18] 5.6	75.1 [22.01] 68.9 [20.19] 5.7	71.7 [21.01] 62.6 [18.35] 5.6	68.3 [20.02] 56.3 [16.50] 5.5
	90 [32.2]	Total BTUH [kW] Sens BTUH [kW] Power	82.9 [24.30] 51.1 [14.98] 6.2	79.5 [23.30] 44.8 [13.13] 6.1	76.1 [22.30] 38.5 [11.28] 5.9	79.9 [23.42] 60.6 [17.76] 6.2	76.5 [22.42] 54.3 [15.91] 6.0	73.0 [21.39] 48.0 [14.07] 5.9	74.4 [21.80] 68.6 [20.10] 6.0	71.0 [20.81] 62.3 [18.26] 5.9	67.6 [19.81] 56.0 [16.41] 5.8
	95 [35]	Total BTUH [kW] Sens BTUH [kW] Power	81.8 [23.97] 50.6 [14.83] 6.5	78.4 [22.98] 44.3 [12.98] 6.4	75.0 [21.98] 38.0 [11.14] 6.3	78.8 [23.09] 60.1 [17.61] 6.5	75.4 [22.10] 53.9 [15.80] 6.3	71.9 [21.07] 47.6 [13.95] 6.2	73.3 [21.48] 68.1 [19.96] 6.4	69.9 [20.49] 61.8 [18.11] 6.2	66.4 [19.46] 55.5 [16.27] 6.1
	100 [37.8]	Total BTUH [kW] Sens BTUH [kW] Power	80.2 [23.50] 49.9 [14.62] 6.8	76.8 [22.51] 43.6 [12.78] 6.7	73.4 [21.51] 37.4 [10.96] 6.6	77.2 [22.63] 59.5 [17.44] 6.8	73.7 [21.60] 53.2 [15.59] 6.7	70.3 [20.60] 46.9 [13.75] 6.5	71.7 [21.01] 67.4 [19.75] 6.7	68.2 [19.99] 61.1 [17.91] 6.6	64.8 [18.99] 54.9 [16.09] 6.4
	105 [40.6]	Total BTUH [kW] Sens BTUH [kW] Power	77.9 [22.83] 48.9 [14.33] 7.2	74.5 [21.83] 42.6 [12.48] 7.0	71.1 [20.84] 36.4 [10.67] 6.9	74.9 [21.95] 58.5 [17.14] 7.1	71.4 [20.93] 52.2 [15.30] 7.0	68.0 [19.93] 45.9 [13.45] 6.9	69.4 [20.34] 66.4 [19.46] 7.0	66.0 [19.34] 60.1 [17.61] 6.9	62.5 [18.32] 53.9 [15.80] 6.8
	110 [43.3]	Total BTUH [kW] Sens BTUH [kW] Power	74.8 [21.92] 47.5 [13.92] 7.5	71.4 [20.93] 41.2 [12.07] 7.4	67.9 [19.90] 35.0 [10.26] 7.2	71.7 [21.01] 57.1 [16.73] 7.4	68.3 [20.02] 50.8 [14.89] 7.3	64.9 [19.02] 44.5 [13.04] 7.2	66.2 [19.40] 65.0 [19.05] 7.3	62.8 [18.40] 58.7 [17.20] 7.2	59.4 [17.41] 52.5 [15.39] 7.1
	115 [46.1]	Total BTUH [kW] Sens BTUH [kW] Power	70.7 [20.72] 45.6 [13.36] 7.8	67.2 [19.69] 39.3 [11.52] 7.7	63.8 [18.70] 33.0 [9.67] 7.6	67.6 [19.81] 55.2 [16.18] 7.8	64.2 [18.82] 48.9 [14.33] 7.6	60.8 [17.82] 42.6 [12.48] 7.5	62.1 [18.20] 62.1 [18.20] 7.7	58.7 [17.20] 56.8 [16.65] 7.5	55.3 [16.21] 50.6 [14.83] 7.4

GROSS SYSTEMS PERFORMANCE DATA—A085

		ENTERING INDOOR AIR @ 80°F [26.7°C] dbE ①									
wbE		71°F [21.7°C]			67°F [19.4°C]			63°F [17.2°C]			
CFM [L/s]		3560 [1680.1]	2850 [1345.1]	2140 [1010.0]	3560 [1680.1]	2850 [1345.1]	2140 [1010.0]	3560 [1680.1]	2850 [1345.1]	2140 [1010.0]	
DR ①		.16	.12	.07	.16	.12	.07	.16	.12	.07	
OUTDOOR DRY BULB TEMPERATURE °F [°C]	75 [23.9]	Total BTUH [kW] Sens BTUH [kW] Power	102.3 [29.97] 64.5 [18.90] 6.6	98.2 [28.77] 56.6 [16.58] 6.4	94.2 [27.60] 48.7 [14.27] 6.2	95.7 [28.04] 75.6 [22.15] 6.5	91.6 [26.84] 67.7 [19.84] 6.3	87.6 [25.67] 59.8 [17.52] 6.1	92.9 [27.22] 87.2 [25.55] 6.4	88.9 [26.05] 79.2 [23.21] 6.2	84.8 [24.85] 71.3 [20.90] 6.1
	80 [26.7]	Total BTUH [kW] Sens BTUH [kW] Power	101.9 [29.86] 64.6 [18.93] 7.0	97.8 [28.66] 56.7 [16.61] 6.8	93.7 [27.45] 48.8 [14.30] 6.7	95.3 [27.92] 75.8 [22.21] 6.9	91.2 [26.72] 67.9 [19.89] 6.7	87.1 [25.52] 59.9 [17.55] 6.5	92.5 [27.10] 87.3 [25.58] 6.8	88.4 [25.90] 79.4 [23.26] 6.6	84.4 [24.73] 71.4 [20.92] 6.5
	85 [29.4]	Total BTUH [kW] Sens BTUH [kW] Power	101.5 [29.74] 64.8 [18.99] 7.4	97.4 [28.54] 56.9 [16.67] 7.2	93.3 [27.34] 49.0 [14.36] 7.1	94.9 [27.81] 75.9 [22.24] 7.3	90.8 [26.60] 68.0 [19.92] 7.1	86.8 [25.43] 60.1 [17.61] 6.9	92.1 [26.99] 87.4 [25.61] 7.2	88.1 [25.81] 79.5 [23.29] 7.0	84.0 [24.61] 71.6 [20.98] 6.9
	90 [32.2]	Total BTUH [kW] Sens BTUH [kW] Power	101.0 [29.59] 64.9 [19.02] 7.8	96.9 [28.39] 56.9 [16.67] 7.6	92.8 [27.19] 49.0 [14.36] 7.5	94.4 [27.66] 76.0 [22.27] 7.7	90.3 [26.46] 68.1 [19.95] 7.5	86.3 [25.29] 60.1 [17.61] 7.3	91.6 [26.84] 87.5 [25.64] 7.6	87.6 [25.67] 79.6 [23.32] 7.4	83.5 [24.47] 71.7 [21.01] 7.3
	95 [35]	Total BTUH [kW] Sens BTUH [kW] Power	100.2 [29.36] 64.7 [18.96] 8.2	96.1 [28.16] 56.8 [16.64] 8.0	92.0 [26.96] 48.9 [14.33] 7.9	93.6 [18.06] 75.8 [22.21] 8.1	89.5 [26.22] 67.9 [19.89] 7.9	85.5 [25.05] 60.0 [17.58] 7.7	90.8 [26.60] 87.4 [25.61] 8.0	86.8 [25.43] 79.4 [23.26] 7.9	82.7 [24.23] 71.5 [20.95] 7.7
	100 [37.8]	Total BTUH [kW] Sens BTUH [kW] Power	98.9 [28.98] 64.2 [18.81] 8.6	94.9 [27.81] 56.3 [16.50] 8.4	90.8 [26.60] 48.4 [14.18] 8.3	92.4 [27.07] 75.4 [22.09] 8.5	88.3 [25.87] 67.4 [19.75] 8.3	84.2 [24.67] 59.5 [17.43] 8.2	89.6 [26.25] 86.9 [25.46] 8.4	85.5 [25.05] 78.9 [23.12] 8.3	81.4 [23.85] 71.0 [20.81] 8.1
	105 [40.6]	Total BTUH [kW] Sens BTUH [kW] Power	97.0 [28.42] 63.3 [18.55] 9.0	93.0 [27.25] 55.3 [16.20] 8.8	88.9 [26.05] 47.4 [13.89] 8.7	90.5 [26.52] 74.4 [21.80] 8.9	86.4 [25.32] 66.5 [19.48] 8.7	82.3 [24.11] 58.6 [17.17] 8.6	87.7 [25.70] 85.9 [25.17] 8.8	83.6 [24.50] 78.0 [22.85] 8.7	79.6 [23.32] 70.1 [20.54] 8.5
	110 [43.3]	Total BTUH [kW] Sens BTUH [kW] Power	94.4 [27.66] 61.7 [18.08] 9.4	90.3 [26.46] 53.8 [15.76] 9.3	86.2 [25.26] 45.9 [13.45] 9.1	87.8 [25.73] 72.9 [21.36] 9.3	83.7 [24.52] 64.9 [19.02] 9.1	79.6 [23.32] 57.0 [16.70] 9.0	85.0 [24.91] 84.4 [24.73] 9.2	80.9 [23.70] 76.4 [22.39] 9.1	76.9 [22.53] 68.5 [20.07] 8.9
	115 [46.1]	Total BTUH [kW] Sens BTUH [kW] Power	90.7 [26.58] 59.5 [17.43] 9.8	86.6 [25.37] 51.6 [15.12] 9.7	82.6 [24.20] 43.6 [12.77] 9.5	84.1 [24.64] 70.6 [20.69] 9.7	80.1 [23.47] 62.7 [18.37] 9.5	76.0 [22.27] 54.8 [16.06] 9.4	81.4 [23.85] 81.4 [23.85] 9.6	77.3 [22.65] 74.2 [21.74] 9.5	73.2 [21.45] 66.3 [19.43] 9.3

DR —Depression ratio
dbE—Entering air dry bulb
wbE—Entering air wet bulb

Total —Total capacity x 1000 BTUH
Sens —Sensible capacity x 1000 BTUH
Power—KW input

NOTES: ① When the entering air dry bulb is other than 80°F [27°C], adjust the sensible capacity from the table by adding $[1.10 \times \text{CFM} \times (1 - \text{DR}) \times (\text{dbE} - 80)]$.

[] Designates Metric Conversions



GROSS SYSTEMS PERFORMANCE DATA—A072

wbE		ENTERING INDOOR AIR @ 80°F [26.7°C] dbE ①									
		71°F [21.7°C]			67°F [19.4°C]			63°F [17.2°C]			
		3000 [1415.8]	2400 [1132.7]	1800 [849.5]	3000 [1415.8]	2400 [1132.7]	1800 [849.5]	3000 [1415.8]	2400 [1132.7]	1800 [849.5]	
CFM [L/s]		.19	.15	.10	.19	.15	.10	.19	.15	.10	
DR ①											
OUTDOOR DRY BULB TEMPERATURE °F [°C]	75 [23.9]	Total BTUH [kW]	83.5 [24.47]	80.1 [23.47]	76.7 [22.48]	81.6 [23.91]	78.2 [22.92]	74.8 [21.92]	77.1 [22.60]	73.7 [21.60]	70.3 [20.60]
		Sens BTUH [kW]	55.3 [16.21]	48.7 [14.27]	42.2 [12.37]	64.6 [18.93]	58.0 [17.00]	51.5 [15.09]	74.1 [21.72]	67.6 [19.81]	61.0 [17.88]
		Power	4.8	4.7	4.6	4.9	4.8	4.7	4.7	4.6	4.5
	80 [26.7]	Total BTUH [kW]	82.8 [24.27]	79.4 [23.27]	76.0 [22.27]	80.9 [23.71]	77.5 [22.71]	74.1 [21.72]	76.4 [22.39]	73.0 [21.39]	69.6 [20.40]
		Sens BTUH [kW]	55.2 [16.18]	48.6 [14.24]	42.1 [12.34]	64.5 [18.90]	57.9 [16.97]	51.4 [15.06]	74.0 [21.69]	67.5 [19.78]	60.9 [17.85]
		Power	5.2	5.0	4.9	5.3	5.1	5.0	5.1	4.9	4.8
	85 [29.4]	Total BTUH [kW]	82.2 [24.09]	78.8 [23.09]	75.4 [22.10]	80.3 [23.53]	76.9 [22.54]	73.5 [21.54]	75.8 [22.21]	72.4 [21.22]	69.0 [20.22]
		Sens BTUH [kW]	54.7 [16.03]	48.2 [14.13]	41.7 [12.22]	64.0 [18.76]	57.5 [16.85]	51.0 [14.95]	73.6 [21.57]	67.1 [19.67]	60.5 [17.73]
		Power	5.5	5.4	5.2	5.6	5.5	5.3	5.4	5.3	5.2
	90 [32.2]	Total BTUH [kW]	81.5 [23.89]	78.1 [22.89]	74.7 [21.89]	79.6 [23.33]	76.2 [22.33]	72.8 [21.34]	75.1 [22.01]	71.7 [21.01]	68.3 [20.02]
Sens BTUH [kW]		54.1 [15.86]	47.5 [13.92]	41.0 [12.02]	63.4 [18.58]	56.8 [16.65]	50.3 [14.74]	72.9 [21.36]	66.4 [19.46]	59.8 [17.53]	
Power		5.8	5.7	5.6	5.9	5.8	5.7	5.7	5.6	5.5	
95 [35]	Total BTUH [kW]	80.6 [23.62]	77.2 [22.63]	73.7 [21.60]	78.7 [23.06]	75.3 [22.07]	71.9 [21.07]	74.2 [21.75]	70.7 [20.72]	67.3 [19.72]	
	Sens BTUH [kW]	53.2 [15.59]	46.7 [13.69]	40.2 [11.78]	62.5 [18.32]	56.0 [16.41]	49.5 [14.51]	72.1 [21.13]	65.5 [19.20]	59.0 [17.29]	
	Power	6.2	6.0	5.9	6.3	6.1	6.0	6.1	6.0	5.8	
100 [37.8]	Total BTUH [kW]	79.3 [23.24]	75.8 [22.21]	72.4 [21.22]	77.4 [22.68]	74.0 [21.69]	70.5 [20.66]	72.8 [21.34]	69.4 [20.34]	66.0 [19.34]	
	Sens BTUH [kW]	52.3 [15.33]	45.8 [13.42]	39.2 [11.49]	61.6 [18.05]	55.1 [16.15]	48.5 [14.21]	71.1 [20.84]	64.6 [18.93]	58.1 [17.03]	
	Power	6.5	6.4	6.2	6.6	6.5	6.4	6.4	6.3	6.2	
105 [40.6]	Total BTUH [kW]	77.4 [22.68]	74.0 [21.69]	70.6 [20.69]	75.5 [22.13]	72.1 [21.13]	68.7 [20.13]	71.0 [20.81]	67.6 [19.81]	64.1 [18.79]	
	Sens BTUH [kW]	51.4 [15.06]	44.9 [13.16]	38.3 [11.22]	60.7 [17.79]	54.2 [15.88]	47.6 [13.95]	70.2 [20.57]	63.7 [18.67]	57.2 [16.76]	
	Power	6.8	6.7	6.6	6.9	6.8	6.7	6.8	6.6	6.5	
110 [43.3]	Total BTUH [kW]	74.8 [21.92]	71.4 [20.93]	68.0 [19.93]	72.9 [21.36]	69.5 [20.37]	66.1 [19.37]	68.4 [20.05]	65.0 [19.05]	61.6 [18.05]	
	Sens BTUH [kW]	50.6 [14.83]	44.1 [12.92]	37.5 [10.99]	59.9 [17.55]	53.3 [15.62]	46.8 [13.72]	68.4 [20.05]	62.9 [18.43]	56.4 [16.53]	
	Power	7.2	7.1	6.9	7.3	7.2	7.0	7.1	7.0	6.8	
115 [46.1]	Total BTUH [kW]	71.4 [20.93]	68.0 [19.93]	64.6 [18.93]	69.5 [20.37]	66.1 [19.37]	62.7 [18.38]	65.0 [19.05]	61.6 [18.05]	58.2 [17.06]	
	Sens BTUH [kW]	49.9 [14.62]	43.4 [12.72]	36.9 [10.81]	59.2 [17.35]	52.7 [15.44]	46.2 [13.54]	65.0 [19.05]	61.6 [18.05]	55.7 [16.32]	
	Power	7.5	7.4	7.3	7.6	7.5	7.4	7.4	7.3	7.2	

DR —Depression ratio
 dbE—Entering air dry bulb
 wbE—Entering air wet bulb

Total —Total capacity x 1000 BTUH
 Sens —Sensible capacity x 1000 BTUH
 Power—KW input

NOTES: ① When the entering air dry bulb is other than 80°F [27°C], adjust the sensible capacity from the table by adding [1.10 x CFM x (1 - DR) x (dbE - 80)].

[] Designates Metric Conversions

AIRFLOW PERFORMANCE—DIRECT DRIVE RKKA/RKMA- SERIES



Capacity		3 Ton [10.55 kW]—10 SEER—80,000 BTU/HR [23.45 kW] Heating Input (1/2 HP [373 W])																							
Operation		Heating										Cooling													
Voltage		208					230					208					230								
Motor Speed		Low		Med.		High		Low		Med.		High		Low		Med.		High		Low		Med.		High	
CFM [L/s] Watts	CFM [L/s]	W	CFM [L/s]	W	CFM [L/s]	W	CFM [L/s]	W	CFM [L/s]	W	CFM [L/s]	W	CFM [L/s]	W	CFM [L/s]	W	CFM [L/s]	W	CFM [L/s]	W	CFM [L/s]	W	CFM [L/s]	W	
.10 E.S.P. [.025 kPa]	1210 [571]	450	—	—	—	—	1400 [661]	470	—	—	—	—	1210 [571]	405	—	—	—	—	1400 [661]	470	—	—	—	—	
.20 E.S.P. [.050 kPa]	1193 [563]	400	—	—	—	—	1375 [649]	460	—	—	—	—	1195 [564]	400	—	—	—	—	1375 [649]	460	—	—	—	—	
.30 E.S.P. [.075 kPa]	1175 [555]	395	—	—	—	—	1360 [642]	455	—	—	—	—	1175 [555]	395	—	—	—	—	1360 [642]	455	—	—	—	—	
.40 E.S.P. [.10 kPa]	1155 [545]	385	—	—	—	—	1335 [630]	450	—	—	—	—	1155 [545]	385	—	—	—	—	1335 [630]	450	—	—	—	—	
.50 E.S.P. [.12 kPa]	1125 [531]	380	—	—	—	—	1305 [616]	440	—	—	—	—	1125 [531]	380	—	—	—	—	1305 [616]	440	—	—	—	—	
.60 E.S.P. [.15 kPa]	1075 [507]	375	1350 [637]	475	—	—	1255 [592]	435	—	—	—	—	1075 [507]	375	1350 [637]	475	—	—	1255 [592]	435	—	—	—	—	
.70 E.S.P. [.17 kPa]	1015 [479]	370	1275 [602]	460	—	—	1210 [571]	425	1350 [637]	505	—	—	1015 [479]	370	1275 [602]	460	—	—	1210 [571]	425	1350 [637]	505	—	—	
.80 E.S.P. [.20 kPa]	925 [437]	360	1180 [557]	445	1280 [604]	515	1100 [519]	410	1230 [580]	475	1375 [649]	555	925 [437]	360	1180 [557]	445	1280 [604]	515	1100 [519]	410	1230 [580]	475	1375 [649]	555	

Capacity		3 Ton [10.55 kW]—10 SEER—120,000 BTU/HR [35.17 kW] Heating Input (1/2 HP [373 W])																							
Operation		Heating										Cooling													
Voltage		208					230					208					230								
Motor Speed		Low		Med.		High		Low		Med.		High		Low		Med.		High		Low		Med.		High	
CFM [L/s] Watts	CFM [L/s]	W	CFM [L/s]	W	CFM [L/s]	W	CFM [L/s]	W	CFM [L/s]	W	CFM [L/s]	W	CFM [L/s]	W	CFM [L/s]	W	CFM [L/s]	W	CFM [L/s]	W	CFM [L/s]	W	CFM [L/s]	W	
.10 E.S.P. [.025 kPa]	1210 [571]	405	1515 [715]	525	1680 [793]	650	1400 [661]	470	1685 [795]	635	1870 [883]	780	1210 [571]	405	—	—	—	—	1400 [661]	470	—	—	—	—	
.20 E.S.P. [.050 kPa]	1195 [564]	400	1500 [708]	515	1650 [779]	640	1375 [649]	460	1620 [765]	600	1830 [864]	760	1195 [564]	400	—	—	—	—	1375 [649]	460	—	—	—	—	
.30 E.S.P. [.075 kPa]	1175 [555]	375	—	—	1625 [767]	630	—	—	1580 [746]	580	1790 [845]	740	1175 [555]	395	—	—	—	—	1360 [642]	455	—	—	—	—	
.40 E.S.P. [.10 kPa]	—	—	—	—	1580 [746]	610	—	—	—	—	1730 [816]	700	1155 [545]	385	1475 [696]	505	—	—	1335 [630]	450	—	—	—	—	
.50 E.S.P. [.12 kPa]	—	—	—	—	1530 [722]	580	—	—	—	—	1660 [783]	660	1125 [531]	380	1405 [663]	490	—	—	1305 [616]	440	1500 [708]	—	—	—	
.60 E.S.P. [.15 kPa]	—	—	—	—	1460 [689]	560	—	—	—	—	1580 [746]	635	1075 [507]	375	1350 [637]	475	1460 [689]	560	1255 [592]	435	1430 [675]	535	—	—	
.70 E.S.P. [.17 kPa]	—	—	—	—	1390 [656]	545	—	—	—	—	1500 [708]	600	1015 [479]	370	1275 [602]	460	1398 [656]	545	1210 [571]	425	1350 [637]	545	1500 [708]	603	
.80 E.S.P. [.20 kPa]	—	—	—	—	1280 [604]	515	—	—	—	—	1375 [649]	555	925 [437]	360	1180 [557]	445	1280 [604]	515	1100 [519]	410	1230 [580]	475	1375 [649]	555	

Capacity		3 Ton [10.55 kW]—10 SEER—80,000/120,000 BTU/HR [23.45/35.17 kW] Heating Input (1/2 HP [373 W])											
Operation		Heating						Cooling					
Voltage		460						460					
Motor Speed		Low		Med.		High		Low		Med.		High	
CFM [L/s] Watts	CFM [L/s]	W	CFM [L/s]	W	CFM [L/s]	W	CFM [L/s]	W	CFM [L/s]	W	CFM [L/s]	W	
.10 E.S.P. [.025 kPa]	1400 [661]	470	—	—	—	—	1400 [661]	470	—	—	—	—	
.20 E.S.P. [.050 kPa]	1375 [649]	460	—	—	—	—	1375 [649]	460	—	—	—	—	
.30 E.S.P. [.075 kPa]	1360 [642]	455	—	—	—	—	1360 [642]	455	—	—	—	—	
.40 E.S.P. [.10 kPa]	1335 [630]	450	—	—	—	—	1335 [630]	450	—	—	—	—	
.50 E.S.P. [.12 kPa]	1305 [616]	440	—	—	—	—	1305 [616]	440	—	—	—	—	
.60 E.S.P. [.15 kPa]	1255 [592]	435	—	—	—	—	1255 [592]	435	—	—	—	—	
.70 E.S.P. [.17 kPa]	1210 [571]	425	—	—	—	—	1210 [571]	425	—	—	—	—	
.80 E.S.P. [.20 kPa]	1100 [519]	410	—	—	—	—	1100 [519]	410	—	—	—	—	

NOTES: 1. Data shown is with dry coil conditions. See wet coil pressure drop. 2. Data includes 1" filters. [] Designates Metric Conversions
 460 volt direct drive does not allow for operation at separate speeds for heating and cooling. Any speed change must be made at the motor terminals and will be reflected in both heating and cooling operation.



AIRFLOW PERFORMANCE—DIRECT DRIVE RKKA/RKMA- SERIES

Capacity		3 1/2 Ton [12.31 kW]—10 SEER—80,000 BTU/HR [23.45 kW] Heating Input (1/2 HP [373 W])																							
Operation		Heating												Cooling											
Voltage		208						230						208						230					
Motor Speed		Low		Med.		High		Low		Med.		High		Low		Med.		High		Low		Med.		High	
CFM [L/s] Watts	CFM [L/s]	W	CFM [L/s]	W	CFM [L/s]	W	CFM [L/s]	W	CFM [L/s]	W	CFM [L/s]	W	CFM [L/s]	W	CFM [L/s]	W	CFM [L/s]	W	CFM [L/s]	W	CFM [L/s]	W	CFM [L/s]	W	
.10 E.S.P. [.025 kPa]	1210 [571]	405	—	—	—	—	1400 [661]	470	—	—	—	—	1210 [571]	405	1515 [715]	525	—	—	1400 [661]	470	1685 [782]	635	—	—	
.20 E.S.P. [.050 kPa]	1193 [563]	400	—	—	—	—	1375 [649]	460	—	—	—	—	1195 [564]	400	1500 [708]	515	—	—	1375 [649]	460	1620 [765]	600	—	—	
.30 E.S.P. [.075 kPa]	1175 [555]	395	—	—	—	—	1360 [642]	455	—	—	—	—	—	—	1475 [696]	505	—	—	1360 [642]	455	1580 [746]	580	—	—	
.40 E.S.P. [.10 kPa]	1155 [545]	385	—	—	—	—	1335 [639]	450	—	—	—	—	—	—	1450 [684]	500	1580 [746]	610	—	—	1550 [732]	570	1720 [812]	—	
.50 E.S.P. [.12 kPa]	1125 [531]	380	—	—	—	—	1305 [616]	440	—	—	—	—	—	—	1405 [663]	490	1530 [722]	580	—	—	1500 [708]	550	1660 [783]	660	
.60 E.S.P. [.15 kPa]	1075 [507]	375	1350 [637]	475	—	—	1255 [592]	435	—	—	—	—	—	—	1350 [637]	475	1460 [689]	560	—	—	1430 [675]	535	1580 [746]	635	
.70 E.S.P. [.17 kPa]	1015 [479]	370	1275 [602]	460	1390 [656]	545	1210 [571]	425	1350 [637]	505	—	—	—	—	1275 [602]	460	1390 [656]	545	—	—	1350 [637]	505	1500 [708]	600	
.80 E.S.P. [.20 kPa]	925 [437]	360	1180 [557]	445	1280 [604]	515	1100 [519]	410	1230 [580]	475	1375 [649]	555	—	—	1180 [557]	445	1280 [604]	515	—	—	1230 [580]	475	1375 [649]	555	

Capacity		3 1/2 Ton [12.31 kW]—10 SEER—120,000 BTU/HR [35.17 kW] Heating Input (1/2 HP [373 W])																							
Operation		Heating												Cooling											
Voltage		208						230						208						230					
Motor Speed		Low		Med.		High		Low		Med.		High		Low		Med.		High		Low		Med.		High	
CFM [L/s] Watts	CFM [L/s]	W	CFM [L/s]	W	CFM [L/s]	W	CFM [L/s]	W	CFM [L/s]	W	CFM [L/s]	W	CFM [L/s]	W	CFM [L/s]	W	CFM [L/s]	W	CFM [L/s]	W	CFM [L/s]	W	CFM [L/s]	W	
.10 E.S.P. [.025 kPa]	1210 [571]	405	1515 [715]	525	1680 [793]	650	1400 [661]	470	1685 [795]	635	1870 [883]	780	1210 [571]	405	1515 [715]	525	1680 [793]	650	1400 [661]	470	1685 [795]	635	—	—	
.20 E.S.P. [.050 kPa]	1125 [574]	400	1500 [708]	515	1650 [779]	640	1375 [649]	460	1620 [765]	600	1830 [864]	760	1195 [564]	400	1500 [708]	515	1630 [769]	640	1375 [649]	460	1620 [765]	600	—	—	
.30 E.S.P. [.075 kPa]	1125 [555]	395	1475 [696]	505	1625 [767]	630	1360 [642]	455	1580 [746]	580	1790 [845]	740	1175 [555]	395	1475 [696]	505	1625 [767]	630	1360 [642]	455	1580 [746]	580	—	—	
.40 E.S.P. [.10 kPa]	1155 [545]	385	1450 [684]	500	1580 [746]	610	—	—	1550 [732]	570	1730 [816]	700	—	—	1450 [684]	500	1580 [746]	610	—	—	1550 [732]	570	1730 [816]	700	
.50 E.S.P. [.12 kPa]	—	—	1405 [663]	490	1530 [722]	580	—	—	—	—	1660 [783]	660	—	—	1405 [663]	490	1530 [722]	580	—	—	1500 [708]	550	1580 [783]	660	
.60 E.S.P. [.15 kPa]	—	—	—	—	1460 [689]	560	—	—	—	—	1580 [746]	635	—	—	1350 [637]	475	1460 [689]	560	—	—	1430 [675]	535	1580 [746]	635	
.70 E.S.P. [.17 kPa]	—	—	—	—	1390 [656]	545	—	—	—	—	1500 [708]	600	—	—	1275 [602]	460	1390 [656]	545	—	—	1350 [637]	505	1500 [708]	600	
.80 E.S.P. [.20 kPa]	—	—	—	—	1280 [604]	515	—	—	—	—	1375 [649]	555	—	—	1180 [557]	445	1280 [604]	515	—	—	1230 [580]	475	1375 [649]	555	

Capacity		3 1/2 Ton [12.31 kW]—10 SEER—80,000/120,000 BTU/HR [23.45/35.17 kW] Heating Input (1/2 HP [373 W])											
Operation		Heating						Cooling					
Voltage		460						460					
Motor Speed		Low		Med.		High		Low		Med.		High	
CFM [L/s] Watts	CFM [L/s]	W	CFM [L/s]	W	CFM [L/s]	W	CFM [L/s]	W	CFM [L/s]	W	CFM [L/s]	W	
.10 E.S.P. [.025 kPa]	—	—	1685 [795]	635	—	—	—	—	—	—	1685 [795]	635	
.20 E.S.P. [.050 kPa]	—	—	1620 [765]	600	—	—	—	—	—	—	1620 [765]	600	
.30 E.S.P. [.075 kPa]	—	—	1580 [746]	580	—	—	—	—	—	—	1580 [746]	580	
.40 E.S.P. [.10 kPa]	—	—	1550 [732]	570	—	—	—	—	—	—	1550 [732]	570	
.50 E.S.P. [.12 kPa]	—	—	1500 [708]	550	—	—	—	—	—	—	1500 [708]	550	
.60 E.S.P. [.15 kPa]	—	—	1430 [675]	535	—	—	—	—	—	—	1430 [675]	535	
.70 E.S.P. [.17 kPa]	—	—	1350 [637]	505	—	—	—	—	—	—	1350 [637]	505	
.80 E.S.P. [.20 kPa]	—	—	1230 [580]	475	—	—	—	—	—	—	1230 [580]	475	

NOTES: 1. Data shown is with dry coil conditions. See wet coil pressure drop. 2. Data includes 1" filters. [] Designates Metric Conversions
 460 volt direct drive does not allow for operation at separate speeds for heating and cooling. Any speed change must be made at the motor terminals and will be reflected in both heating and cooling operation.

AIRFLOW PERFORMANCE—DIRECT DRIVE RKKA/RKMA- SERIES



Capacity		4 Ton [14.07 kW]—10 SEER—100,000 BTU/HR [29.31 kW] Heating Input (1/2 HP [373 W])																							
Operation		Heating												Cooling											
Voltage		208						230						208						230					
Motor Speed		Low		Med.		High		Low		Med.		High		Low		Med.		High		Low		Med.		High	
CFM [L/s] Watts	CFM [L/s]	W	CFM [L/s]	W	CFM [L/s]	W	CFM [L/s]	W	CFM [L/s]	W	CFM [L/s]	W	CFM [L/s]	W	CFM [L/s]	W	CFM [L/s]	W	CFM [L/s]	W	CFM [L/s]	W	CFM [L/s]	W	
.10 E.S.P. [.025 kPa]	1210 [571]	405	1515 [715]	525	—	—	1400 [661]	470	1685 [795]	635	—	—	—	—	1515 [715]	525	1680 [793]	650	1400 [661]	490	1685 [795]	635	1870 [883]	780	
.20 E.S.P. [.050 kPa]	—	—	1500 [708]	515	—	—	1375 [649]	460	1620 [765]	600	—	—	—	—	1500 [708]	515	1650 [779]	640	—	—	1620 [765]	600	1830 [864]	760	
.30 E.S.P. [.075 kPa]	—	—	1475 [696]	505	—	—	1360 [642]	455	1580 [746]	580	—	—	—	—	1475 [696]	505	1625 [767]	630	—	—	1580 [746]	580	1790 [845]	740	
.40 E.S.P. [.10 kPa]	—	—	1450 [684]	500	—	—	—	—	1550 [732]	570	—	—	—	—	1450 [684]	500	1580 [746]	610	—	—	1550 [732]	570	1730 [816]	700	
.50 E.S.P. [.12 kPa]	—	—	1405 [663]	490	—	—	—	—	1500 [708]	550	—	—	—	—	—	—	1530 [722]	580	—	—	—	—	1660 [783]	660	
.60 E.S.P. [.15 kPa]	—	—	1350 [637]	475	1460 [689]	560	—	—	1430 [675]	535	1380 [651]	635	—	—	—	—	1460 [689]	560	—	—	—	—	1580 [746]	635	
.70 E.S.P. [.17 kPa]	—	—	1275 [602]	460	1390 [656]	545	—	—	1350 [637]	505	1500 [708]	600	—	—	—	—	1390 [656]	545	—	—	—	—	1500 [708]	600	
.80 E.S.P. [.20 kPa]	—	—	1180 [557]	445	1280 [604]	515	—	—	1230 [580]	475	1375 [649]	555	—	—	—	—	1280 [604]	515	—	—	—	—	1375 [649]	555	

Capacity		4 Ton [14.07 kW]—10 SEER—135,000 BTU/HR [39.56 kW] Heating Input (1/2 HP [373 W])																							
Operation		Heating												Cooling											
Voltage		208						230						208						230					
Motor Speed		Low		Med.		High		Low		Med.		High		Low		Med.		High		Low		Med.		High	
CFM [L/s] Watts	CFM [L/s]	W	CFM [L/s]	W	CFM [L/s]	W	CFM [L/s]	W	CFM [L/s]	W	CFM [L/s]	W	CFM [L/s]	W	CFM [L/s]	W	CFM [L/s]	W	CFM [L/s]	W	CFM [L/s]	W	CFM [L/s]	W	
.10 E.S.P. [.025 kPa]	—	—	1515 [715]	525	1680 [793]	650	1400 [661]	470	1685 [795]	635	1870 [883]	780	1210 [571]	405	1515 [715]	525	1680 [793]	650	1400 [661]	470	1685 [795]	635	1870 [883]	780	
.20 E.S.P. [.050 kPa]	—	—	1500 [708]	515	1650 [779]	640	—	—	1620 [765]	600	1830 [864]	760	—	—	1500 [708]	515	1630 [769]	640	1375 [649]	460	1620 [765]	600	1830 [864]	760	
.30 E.S.P. [.075 kPa]	—	—	—	—	1625 [767]	630	—	—	1580 [746]	580	1790 [845]	740	—	—	1475 [696]	505	1625 [767]	630	—	—	1580 [746]	580	1790 [845]	740	
.40 E.S.P. [.10 kPa]	—	—	—	—	1580 [746]	610	—	—	1550 [732]	570	1730 [816]	700	—	—	1450 [684]	500	1580 [746]	610	—	—	1550 [732]	570	1730 [816]	700	
.50 E.S.P. [.12 kPa]	—	—	—	—	1530 [722]	580	—	—	—	—	1660 [783]	660	—	—	—	—	1530 [722]	580	—	—	—	—	1660 [783]	660	
.60 E.S.P. [.15 kPa]	—	—	—	—	1460 [689]	560	—	—	—	—	1580 [746]	635	—	—	—	—	1460 [689]	560	—	—	—	—	1580 [746]	635	
.70 E.S.P. [.17 kPa]	—	—	—	—	1390 [656]	545	—	—	—	—	1500 [708]	600	—	—	—	—	1390 [656]	545	—	—	—	—	1500 [708]	600	
.80 E.S.P. [.20 kPa]	—	—	—	—	1280 [604]	515	—	—	—	—	1375 [649]	555	—	—	—	—	1280 [604]	515	—	—	—	—	1375 [649]	555	

Capacity		4 Ton [14.07 kW]—10 SEER—100,000/135,000 BTU/HR [29.31/39.56 kW] Heating Input (1/2 HP [373 W])											
Operation		Heating						Cooling					
Voltage		460						460					
Motor Speed		Low		Med.		High		Low		Med.		High	
CFM [L/s] Watts	CFM [L/s]	W	CFM [L/s]	W	CFM [L/s]	W	CFM [L/s]	W	CFM [L/s]	W	CFM [L/s]	W	
.10 E.S.P. [.025 kPa]	—	—	—	—	1870 [883]	780	—	—	—	—	1870 [883]	780	
.20 E.S.P. [.050 kPa]	—	—	—	—	1830 [864]	760	—	—	—	—	1830 [864]	760	
.30 E.S.P. [.075 kPa]	—	—	—	—	1790 [845]	740	—	—	—	—	1790 [845]	740	
.40 E.S.P. [.10 kPa]	—	—	—	—	1730 [816]	700	—	—	—	—	1730 [816]	700	
.50 E.S.P. [.12 kPa]	—	—	—	—	1660 [783]	660	—	—	—	—	1660 [783]	660	
.60 E.S.P. [.15 kPa]	—	—	—	—	1580 [746]	635	—	—	—	—	1580 [746]	635	
.70 E.S.P. [.17 kPa]	—	—	—	—	1500 [708]	600	—	—	—	—	1500 [708]	600	
.80 E.S.P. [.20 kPa]	—	—	—	—	1375 [649]	555	—	—	—	—	1375 [649]	555	

NOTES: 1. Data shown is with dry coil conditions. See wet coil pressure drop. 2. Data includes 1" filters. [] Designates Metric Conversions
460 volt direct drive does not allow for operation at separate speeds for heating and cooling. Any speed change must be made at the motor terminals and will be reflected in both heating and cooling operation.



AIRFLOW PERFORMANCE—DIRECT DRIVE RKKA/RKMA- SERIES

Capacity		5 Ton [17.6 kW]—10 SEER—100,000 BTU/HR [29.31 kW] Heating Input (¾ HP [559 W])																							
Operation		Heating												Cooling											
Voltage		208						230						208						230					
Motor Speed		Low		Med.		High		Low		Med.		High		Low		Med.		High		Low		Med.		High	
CFM [L/s] Watts	CFM [L/s]	W	CFM [L/s]	W	CFM [L/s]	W	CFM [L/s]	W	CFM [L/s]	W	CFM [L/s]	W	CFM [L/s]	W	CFM [L/s]	W	CFM [L/s]	W	CFM [L/s]	W	CFM [L/s]	W	CFM [L/s]	W	
.10 E.S.P. [.025 kPa]	1450 [684]	605	—	—	—	—	1690 [798]	750	—	—	—	—	—	—	2050 [967]	830	2180 [1029]	970	—	—	2175 [1026]	980	2400 [1133]	1080	
.20 E.S.P. [.050 kPa]	1425 [673]	590	—	—	—	—	1660 [783]	740	—	—	—	—	—	—	1960 [925]	790	2150 [1015]	940	—	—	2125 [1003]	920	2380 [1123]	1070	
.30 E.S.P. [.075 kPa]	1405 [663]	580	—	—	—	—	1615 [762]	730	—	—	—	—	—	—	1890 [892]	760	2060 [972]	905	—	—	2040 [963]	880	2260 [1067]	1030	
.40 E.S.P. [.10 kPa]	1375 [649]	570	—	—	—	—	1570 [741]	710	—	—	—	—	—	—	1800 [850]	730	1950 [920]	860	—	—	1930 [911]	860	2180 [1029]	980	
.50 E.S.P. [.12 kPa]	1335 [630]	560	—	—	—	—	1310 [618]	680	—	—	—	—	—	—	—	—	1830 [864]	820	—	—	1825 [861]	825	2100 [991]	960	
.60 E.S.P. [.15 kPa]	1300 [614]	550	—	—	—	—	1440 [680]	660	—	—	—	—	—	—	—	—	1680 [793]	770	—	—	—	—	2000 [944]	930	
.70 E.S.P. [.17 kPa]	1260 [595]	540	—	—	1450 [684]	705	1375 [649]	645	—	—	—	—	—	—	—	—	1450 [684]	705	—	—	—	—	1900 [897]	880	
.80 E.S.P. [.20 kPa]	1220 [576]	530	—	—	1340 [632]	670	1310 [618]	625	—	—	—	—	—	—	—	—	—	—	—	—	—	—	1600 [755]	820	

Capacity		5 Ton [17.6 kW]—10 SEER—135,000 BTU/HR [39.56 kW] Heating Input (¾ HP [559 W])																							
Operation		Heating												Cooling											
Voltage		208						230						208						230					
Motor Speed		Low		Med.		High		Low		Med.		High		Low		Med.		High		Low		Med.		High	
CFM [L/s] Watts	CFM [L/s]	W	CFM [L/s]	W	CFM [L/s]	W	CFM [L/s]	W	CFM [L/s]	W	CFM [L/s]	W	CFM [L/s]	W	CFM [L/s]	W	CFM [L/s]	W	CFM [L/s]	W	CFM [L/s]	W	CFM [L/s]	W	
.10 E.S.P. [.025 kPa]	—	—	2050 [967]	830	2180 [1029]	970	—	—	2175 [1026]	980	2400 [1133]	1080	—	—	—	—	2180 [1029]	970	—	—	2175 [1026]	980	2400 [1133]	1080	
.20 E.S.P. [.050 kPa]	—	—	1960 [925]	790	2150 [1015]	940	—	—	2123 [1002]	920	2380 [1123]	1070	—	—	—	—	2150 [1015]	940	—	—	2125 [1003]	920	2380 [1123]	1070	
.30 E.S.P. [.075 kPa]	—	—	1860 [878]	760	2060 [972]	905	—	—	2040 [963]	880	2260 [1067]	1030	—	—	—	—	2060 [972]	905	—	—	2040 [963]	880	2260 [1067]	1030	
.40 E.S.P. [.10 kPa]	—	—	1800 [730]	730	1960 [925]	860	—	—	1950 [920]	860	2180 [1029]	980	—	—	—	—	1960 [925]	860	—	—	1930 [911]	860	2180 [1029]	980	
.50 E.S.P. [.12 kPa]	—	—	—	—	1830 [864]	820	—	—	1825 [861]	825	2100 [991]	960	—	—	—	—	1830 [864]	820	—	—	1825 [861]	825	2100 [991]	960	
.60 E.S.P. [.15 kPa]	—	—	—	—	1680 [793]	770	—	—	—	—	2000 [944]	930	—	—	—	—	1680 [793]	770	—	—	—	—	2000 [944]	930	
.70 E.S.P. [.17 kPa]	—	—	—	—	1450 [684]	705	—	—	—	—	1900 [897]	880	—	—	—	—	1450 [684]	705	—	—	—	—	1900 [897]	880	
.80 E.S.P. [.20 kPa]	—	—	—	—	—	—	—	—	—	—	1600 [755]	820	—	—	—	—	—	—	—	—	—	—	1600 [755]	820	

Capacity		5 Ton [17.6 kW]—10 SEER—100,000/135,000 BTU/HR [29.31/39.56 kW] Heating Input (¾ HP [559 W])													
Operation		Heating							Cooling						
Voltage		460							460						
Motor Speed		Low		Med.		High			Low		Med.		High		
CFM [L/s] Watts	CFM [L/s]	W	CFM [L/s]	W	CFM [L/s]	W	CFM [L/s]	W	CFM [L/s]	W	CFM [L/s]	W	CFM [L/s]	W	
.10 E.S.P. [.025 kPa]	—	—	—	—	—	—	2400 [1133]	1080	—	—	—	—	2400 [1133]	1080	
.20 E.S.P. [.050 kPa]	—	—	—	—	—	—	2380 [1123]	1070	—	—	—	—	2380 [1123]	1070	
.30 E.S.P. [.075 kPa]	—	—	—	—	—	—	2260 [1067]	1030	—	—	—	—	2260 [1067]	1030	
.40 E.S.P. [.10 kPa]	—	—	—	—	—	—	2180 [1029]	980	—	—	—	—	2180 [1029]	980	
.50 E.S.P. [.12 kPa]	—	—	—	—	—	—	2100 [991]	960	—	—	—	—	2100 [991]	960	
.60 E.S.P. [.15 kPa]	—	—	—	—	—	—	2000 [944]	930	—	—	—	—	2000 [944]	930	
.70 E.S.P. [.17 kPa]	—	—	—	—	—	—	1900 [897]	880	—	—	—	—	1900 [897]	880	
.80 E.S.P. [.20 kPa]	—	—	—	—	—	—	1600 [755]	820	—	—	—	—	1600 [755]	820	

NOTES: 1. Data shown is with dry coil conditions. See wet coil pressure drop. 2. Data includes 1" filters.
460 volt direct drive does not allow for operation at separate speeds for heating and cooling. Any speed change must be made at the motor terminals and will be reflected in both heating and cooling operation.

[] Designates Metric Conversions



AIRFLOW PERFORMANCE—3 TON [10.55 kW] GAS HEAT MODELS BELT DRIVE

Air Flow CFM [L/s]	Capacity 3 Ton [10.55 kW]—10 SEER		External Static Pressure—Inches of Water [kPa]																													
	Voltage 208/230-460 & 575—3 Phase		0.1 [.02]		0.2 [.05]		0.3 [.07]		0.4 [.10]		0.5 [.12]		0.6 [.15]		0.7 [.17]		0.8 [.20]		0.9 [.22]		1.0 [.25]		1.1 [.27]		1.2 [.30]		1.3 [.32]		1.4 [.35]		1.5 [.37]	
	RPM	W	RPM	W	RPM	W	RPM	W	RPM	W	RPM	W	RPM	W	RPM	W	RPM	W	RPM	W	RPM	W	RPM	W	RPM	W	RPM	W	RPM	W		
900 [425]	—	—	—	—	—	—	—	—	—	—	—	—	—	—	—	—	—	—	—	—	—	—	—	—	—	—	—	—	—	—	—	
1000 [472]	—	—	—	—	—	—	—	—	—	—	—	—	—	—	—	—	—	—	—	—	—	—	—	—	—	—	—	—	—	—	—	
1100 [519]	—	—	—	—	—	—	—	—	—	—	—	—	—	—	—	—	—	—	—	—	—	—	—	—	—	—	—	—	—	—	—	
1200 [566]	605	250	655	270	720	305	775	340	835	370	900	415	955	475	1005	495	1045	540	1095	580	1130	605	1180	655	1210	690	1245	730	1290	780	825	
1300 [614]	620	275	675	300	740	340	805	375	855	400	920	455	970	505	1025	530	1065	575	1115	610	1155	630	1195	680	1220	730	1255	780	1300	825		
1400 [661]	640	305	710	340	775	375	825	395	880	440	940	480	990	520	1035	560	1080	590	1125	650	1170	705	1215	775	1230	810	1270	840	1320	880		
1500 [708]	680	340	745	370	800	405	845	425	910	490	955	535	1005	565	1050	615	1090	660	1135	700	1185	760	1225	820	1240	850	1290	905	1330	940		

NOTE: Bold lines separate L, M and N drives respectively.

Drive Package Motor H.P. [W]	L						M							
	0	1	2	3	4	5	0	1	2	3	4	5	6	
Blower Sheave	1/2 [373]													
Motor Sheave	6.9" Pitch Diameter													
Turns Open	2.4"-3.4" Pitch Diameter													
RPM	920	855	800	750	705	665	605	1230	1180	1130	1090	1045	1000	940

NOTE: Factory sheave settings are shown in bold print.

COMPONENT AIR RESISTANCE

Component	Standard Indoor Airflow—CFM [L/s]						Resistance—Inches Water [kPa]					
	1000 [472]	1200 [566]	1400 [661]	1600 [755]	1800 [850]	2000 [944]	2200 [1038]	2400 [1133]	2600 [1227]	2800 [1321]		
Wet Coil	.035	.040	.060	.070	.085	.100	.110	.120	.125	.130		
Downflow	.055	.060	.066	.072	.080	.086	.093	.100	.107	.115		
R.S.I. Economizer R.A. Damper	.05	.06	.07	.08	.09	.10	.11	.12	.13	.15		

NOTES:

- Performance shown with dry coil & standard 1" [25.4 mm] filters
- Standard CFM @ .075 lbs./cu. ft.
- Motor efficiency = 80% on 208/230, 460, 575 V, 3-Phase
Motor efficiency = 50% on 208/230 V, 1-Phase
- BHP = $\frac{\text{Watts} \times \text{Motor Eff.}}{746}$
- Add component resistance to duct static to determine total E.S.P.

[] Designates Metric Conversions



AIRFLOW PERFORMANCE—3.5 TON [12.31 kW] BELT DRIVE

Air Flow CFM [L/s]	Capacity 3.5 Ton [12.31 kW]—10 SEER Voltage 208/230-460 & 575—3 Phase																																
	External Static Pressure—Inches of Water [kPa]																																
	0.1 [.02]		0.2 [.05]		0.3 [.07]		0.4 [.10]		0.5 [.12]		0.6 [.15]		0.7 [.17]		0.8 [.20]		0.9 [.22]		1.0 [.25]		1.1 [.27]		1.2 [.30]		1.3 [.32]		1.4 [.35]		1.5 [.37]				
	RPM	W	RPM	W	RPM	W	RPM	W	RPM	W	RPM	W	RPM	W	RPM	W	RPM	W	RPM	W	RPM	W	RPM	W	RPM	W	RPM	W	RPM	W	RPM	W	
1000 [425]	—	—	—	—	—	—	—	—	—	—	—	—	—	—	—	—	—	—	—	—	—	—	—	—	—	—	—	—	—				
1100 [519]	—	—	—	—	—	—	735	305	790	325	850	360	895	380	945	400	995	420	1060	455	1105	490	1145	520	1185	550	1220	590	1265	630			
1200 [566]	—	—	—	—	—	750	320	810	355	870	380	915	400	965	415	1010	450	1075	500	1120	520	1160	560	1195	590	1240	640	1275	700				
1300 [614]	—	—	—	—	—	725	335	770	350	835	380	885	410	935	440	985	450	1030	500	1090	540	1130	560	1170	600	1215	650	1255	710	1290	760		
1400 [661]	—	—	—	—	—	745	360	800	395	860	415	905	445	955	465	1005	510	1050	550	1105	590	1140	610	1180	650	1230	710	1270	790	1305	815		
1500 [708]	—	—	—	—	—	725	375	765	395	830	420	880	460	925	490	985	510	1015	560	1065	600	1120	640	1150	665	1190	710	1245	790	1290	850	1325	900
1600 [755]	—	—	—	—	—	740	410	795	440	855	460	905	495	950	540	1000	590	1030	610	1090	650	1135	690	1170	720	1205	765	1260	860	1310	920	1335	980
1700 [802]	775	410	765	445	820	470	875	510	925	540	975	570	1015	640	1055	660	1105	700	1145	745	1185	800	1225	860	1275	860	1325	915	1325	1005	1350	1040	
1800 [850]	740	460	795	495	850	520	900	550	945	600	1000	650	1020	690	1075	740	1125	760	1165	810	1205	865	1240	940	1290	1005	1070	1105	1110	—	—	—	
1900 [897]	800	525	855	560	910	610	965	650	995	700	1035	755	1075	800	1130	840	1175	870	1220	920	1260	955	1305	1010	1350	1070	1385	1115	—	—	—	—	
2000 [944]	830	595	885	640	940	670	970	710	1020	790	1065	840	1115	860	1160	900	1200	950	1240	1010	1295	1060	1330	1105	1375	1160	—	—	—	—	—	—	

NOTE: Bold lines separate L, M and N drives respectively.

Drive Package	L												M																			
	1/2 [373]												1/2 [373]																			
Motor H.P. [W]	6.9" Pitch Diameter												6.4" Pitch Diameter																			
Blower Sheave	2.8"-3.8" Pitch Diameter												4.0"-5.0" Pitch Diameter																			
Turns Open	0	1	2	3	4	5	6	0	1	2	3	4	5	6	0	1	2	3	4	5	6	0	1	2	3	4	5	6				
RPM	958	945	905	865	820	770	725	1225	1185	1145	1100	1060	1020	1000	1185	1145	1100	1060	1020	980	940	900	860	820	780	740	700	660	620	580	540	500

NOTE: Factory sheave settings are shown in bold print.

N Drive (Field Supplied)
Blower Sheave—6.4 Pitch Diameter
Motor Sheave—4.0-5.0 Pitch Diameter
RPM Range—1090-1365
Motor—1/2 H.P. [373 W]—1750 RPM

AIRFLOW PERFORMANCE—4 TON [14.07 kW] BELT DRIVE

Air Flow CFM [L/s]	Capacity 4 Ton [14.07 kW]—10 SEER Voltage 208/230-460 & 575—3 Phase																															
	External Static Pressure—Inches of Water [kPa]																															
	0.1 [.02]		0.2 [.05]		0.3 [.07]		0.4 [.10]		0.5 [.12]		0.6 [.15]		0.7 [.17]		0.8 [.20]		0.9 [.22]		1.0 [.25]		1.1 [.27]		1.2 [.30]		1.3 [.32]		1.4 [.35]		1.5 [.37]			
	RPM	W	RPM	W	RPM	W	RPM	W	RPM	W	RPM	W	RPM	W	RPM	W	RPM	W	RPM	W	RPM	W	RPM	W	RPM	W	RPM	W	RPM	W	RPM	W
1200 [566]	—	—	—	—	—	—	—	—	—	—	—	—	—	—	—	—	—	—	—	—	—	—	—	—	—	—	—	—	—	—	—	
1300 [614]	—	—	—	—	—	—	780	360	835	390	885	410	935	440	975	475	1015	505	1070	550	1120	570	1170	600	1220	635	1265	655	1320	705		
1400 [661]	—	—	—	—	—	—	805	390	855	410	910	450	960	470	990	510	1030	545	1085	590	1135	610	1185	640	1235	685	1285	730	1335	775		
1500 [708]	—	—	—	—	—	—	770	385	825	425	870	445	925	480	960	510	1010	550	1050	600	1105	615	1155	650	1200	700	1245	730	1300	1345	825	
1600 [755]	—	—	—	—	—	—	790	425	850	475	900	490	940	515	980	550	1025	600	1075	640	1125	670	1175	700	1220	745	780	1315	825	1355	855	
1700 [802]	—	—	—	—	—	—	775	425	815	455	870	495	920	530	960	560	1005	605	1050	680	1145	710	1195	755	1235	800	1285	845	1330	890	1370	935
1800 [850]	775	470	850	505	890	540	940	560	980	605	1025	655	1075	715	1120	735	1165	770	1215	810	1270	870	1305	915	1350	945	1385	1000	—	—	—	
1900 [897]	800	525	855	560	910	610	965	650	995	700	1035	755	1075	800	1130	840	1175	870	1220	920	1260	955	1305	1010	1350	1070	1385	1115	—	—	—	
2000 [944]	830	595	885	640	940	670	970	710	1020	790	1065	840	1115	860	1160	900	1200	950	1240	1010	1295	1060	1330	1105	1375	1160	—	—	—	—	—	—

NOTE: L-Drive left of bold line, M-Drive right of bold line.

Drive Package	L												M																			
	1/2 [373]												3/4 [559]																			
Motor H.P. [W]	6.4" Pitch Diameter												5.7" Pitch Diameter																			
Blower Sheave	2.8"-3.8" Pitch Diameter												3.4"-4.4" Pitch Diameter																			
Turns Open	0	1	2	3	4	5	6	0	1	2	3	4	5	6	0	1	2	3	4	5	6	0	1	2	3	4	5	6				
RPM	1060	1000	955	910	865	825	770	1385	1330	1280	1225	1175	1120	1060	1330	1280	1225	1175	1120	1060	1010	955	900	845	790	735	680	625	570	515	460	405

NOTE: Factory sheave settings are shown in bold print.

[] Designates Metric Conversions



AIRFLOW PERFORMANCE—5 TON [17.6 kW] THREE PHASE BELT DRIVE

Air Flow CFM [L/s]	Capacity 5 Ton [17.6 kW]—10 SEER		External Static Pressure—Inches of Water [kPa]																													
	Voltage 208/230-460 & 575—3 Phase		0.1 [.02]		0.2 [.05]		0.3 [.07]		0.4 [.10]		0.5 [.12]		0.6 [.15]		0.7 [1.17]		0.8 [.20]		0.9 [.22]		1.0 [.25]		1.1 [1.27]		1.2 [1.30]		1.3 [.32]		1.4 [.35]		1.5 [.37]	
	RPM	W	RPM	W	RPM	W	RPM	W	RPM	W	RPM	W	RPM	W	RPM	W	RPM	W	RPM	W	RPM	W	RPM	W	RPM	W	RPM	W	RPM	W		
1400 [661]	—	—	—	—	780	370	815	385	875	425	930	460	970	490	1030	540	1065	570	1105	595	1150	615	1195	645	1235	660	1300	705	1340	745		
1500 [708]	—	—	—	—	795	405	840	415	895	440	945	500	995	540	1045	595	1080	615	1135	650	1180	675	1215	700	1255	735	1320	775	1355	805		
1600 [755]	—	—	—	—	780	390	805	425	870	470	915	510	965	560	1015	600	1060	640	1105	680	1145	705	1180	730	1225	750	1340	840	1365	880		
1700 [802]	—	—	—	—	795	450	840	490	895	530	940	570	990	605	1035	640	1075	680	1120	725	1160	755	1200	790	1245	815	1300	855	1375	940		
1800 [850]	780	455	815	470	870	540	915	560	965	615	1010	660	1055	710	1100	760	1140	785	1175	810	1225	850	1260	880	1320	930	1365	985	1390	1020		
1900 [897]	800	485	850	530	895	590	945	640	995	675	1035	720	1070	775	1120	810	1160	850	1200	890	1245	915	1290	960	1335	1000	1375	1050	1405	1100		
2000 [944]	830	550	880	605	930	655	970	700	1015	730	1055	790	1105	830	1145	875	1180	910	1225	950	1260	980	1320	1035	1075	1385	1120	—	—	—		
2100 [991]	860	615	915	665	955	705	1005	760	1040	820	1090	870	1130	910	1170	950	1210	995	1250	1020	1290	1060	1335	1100	1370	1150	1400	1200	—	—	—	
2200 [1038]	895	680	945	735	995	780	1030	830	1060	880	1120	940	1155	980	1195	1020	1240	1055	1275	1100	1320	1140	1360	1180	1385	1225	—	—	—	—	—	
2300 [1085]	940	755	975	795	1015	830	1065	910	1100	965	1150	105	1180	1050	1225	1095	1265	1125	1310	1175	1350	1230	1375	1260	1405	1320	—	—	—	—	—	
2400 [1133]	970	825	1015	880	1040	925	1095	1005	1145	1055	1175	1085	1225	1140	1260	1175	1300	1210	1340	1255	1370	1315	1400	1375	—	—	—	—	—	—	—	
2500 [1179]	1015	910	1040	935	1095	1040	1145	1100	1170	1140	1200	1175	1260	1215	1305	1270	1360	1350	1400	1395	—	—	—	—	—	—	—	—	—	—	—	—

NOTE: L-Drive left of bold line, M-Drive right of bold line.

Drive Package	L	M
Motor H.P. [W]	³ / ₄ [559]	1 [746]
Blower Sheave	6.4" Pitch Diameter	6.4" Pitch Diameter
Motor Sheave	2.8"-3.8" Pitch Diameter—Adj.	3.4"-4.4" Pitch Diameter—Adj.
Turns Open	0	1
RPM	1095 1040 995 940 890 835 780	1405 1360 1305 1250 1195 1145 1095

NOTE: Factory sheave settings are shown in bold print.

[] Designates Metric Conversions



AIRFLOW PERFORMANCE—6 TON [21.10 kW] THREE PHASE BELT DRIVE

Air Flow CFM [L/s]	Capacity 6 Ton [21.10 kW]—9.4 & 10.3 SEER		External Static Pressure—Inches of Water [kPa]																													
	Voltage 208/230-460 & 575—3 Phase		0.1 [.02]		0.2 [.05]		0.3 [.07]		0.4 [.10]		0.5 [.12]		0.6 [.15]		0.7 [.17]		0.8 [.20]		0.9 [.22]		1.0 [.25]		1.1 [.27]		1.2 [.30]		1.3 [.32]		1.4 [.35]		1.5 [.37]	
	RPM	W	RPM	W	RPM	W	RPM	W	RPM	W	RPM	W	RPM	W	RPM	W	RPM	W	RPM	W	RPM	W	RPM	W	RPM	W	RPM	W	RPM	W		
1800 [850]	—	—	—	—	—	—	—	—	—	—	—	—	—	—	—	—	—	—	—	—	—	—	—	—	—	—	—	—	—	—	—	
1900 [897]	—	—	—	—	—	—	—	—	—	—	—	—	—	—	—	—	—	—	—	—	—	—	—	—	—	—	—	—	—	—	—	
2000 [944]	—	—	—	—	—	—	—	—	—	—	—	—	—	—	—	—	—	—	—	—	—	—	—	—	—	—	—	—	—	—	—	
2200 [1038]	—	—	—	—	—	—	—	—	—	—	—	—	—	—	—	—	—	—	—	—	—	—	—	—	—	—	—	—	—	—	—	
2100 [991]	—	—	—	—	—	—	—	—	—	—	—	—	—	—	—	—	—	—	—	—	—	—	—	—	—	—	—	—	—	—	—	
2300 [1085]	—	—	—	—	—	—	—	—	—	—	—	—	—	—	—	—	—	—	—	—	—	—	—	—	—	—	—	—	—	—	—	
2400 [1133]	—	—	—	—	—	—	—	—	—	—	—	—	—	—	—	—	—	—	—	—	—	—	—	—	—	—	—	—	—	—	—	
2500 [1180]	—	—	—	—	—	—	—	—	—	—	—	—	—	—	—	—	—	—	—	—	—	—	—	—	—	—	—	—	—	—	—	
2600 [1227]	—	—	—	—	—	—	—	—	—	—	—	—	—	—	—	—	—	—	—	—	—	—	—	—	—	—	—	—	—	—	—	
2700 [1274]	—	—	—	—	—	—	—	—	—	—	—	—	—	—	—	—	—	—	—	—	—	—	—	—	—	—	—	—	—	—	—	
2800 [1321]	—	—	—	—	—	—	—	—	—	—	—	—	—	—	—	—	—	—	—	—	—	—	—	—	—	—	—	—	—	—	—	

NOTE: L-Drive left of bold line, M-Drive right of bold line.

Drive Package	L												M															
Motor H.P. [W]	1 1/2 [1119]												1 1/2 [1119]															
Blower Sheave	6.4" Pitch Diameter												6.4" Pitch Diameter															
Motor Sheave	2.8"-3.8" Pitch Diameter—Adj.												3.4"-4.4" Pitch Diameter—Adj.															
Turns Open	0	1	2	3	4	5	6	0	1	2	3	4	5	6	0	1	2	3	4	5	6	0	1	2	3	4	5	6
RPM	1100	1050	1000	945	895	845	780	1295	1230	1195	1145	1100	1050	1000	1100	1050	1000	945	895	845	780	1295	1230	1195	1145	1100	1050	1000

NOTE: Factory sheave settings are shown in bold print.

[] Designates Metric Conversions



AIRFLOW PERFORMANCE—7.5 TON [26.4 kW] THREE PHASE BELT DRIVE

Air Flow CFM [L/s]	Capacity 7.5 Ton [26.4 kW]—9.1 SEER			Capacity 208/230-460 & 575—3 Phase			External Static Pressure—Inches of Water [kPa]																																													
	Voltage			Voltage			0.1 [0.02]		0.2 [0.05]		0.3 [0.07]		0.4 [0.10]		0.5 [0.12]		0.6 [0.15]		0.7 [0.17]		0.8 [0.20]		0.9 [0.22]		1.0 [0.25]		1.1 [0.27]		1.2 [0.30]		1.3 [0.32]		1.4 [0.35]		1.5 [0.37]		1.6 [0.40]		1.7 [0.42]		1.8 [0.45]		1.9 [0.47]		2.0 [0.50]							
	RPM	W	RPM	W	RPM	W	RPM	W	RPM	W	RPM	W	RPM	W	RPM	W	RPM	W	RPM	W	RPM	W	RPM	W	RPM	W	RPM	W	RPM	W	RPM	W	RPM	W	RPM	W	RPM	W	RPM	W	RPM	W	RPM	W								
2200 [944]	—	—	—	—	—	—	—	970	929	998	1026	1050	1110	1083	1170	1112	1231	1140	1291	1168	1351	1197	1411	1225	1472	1254	1532	1282	1592	1311	1653	1339	1713	1367	1773	1396	1833	—	—	—	—	—	—	—	—							
2300 [1085]	—	—	—	—	—	—	—	988	1029	1017	1089	1045	1150	1074	1210	1102	1270	1131	1331	1159	1391	1187	1451	1244	1572	1273	1632	1301	1692	1329	1753	1358	1813	1386	1873	—	—	—	—	—	—	—	—	—	—							
2400 [1133]	—	—	—	—	—	—	—	979	1069	1007	1129	1036	1189	1064	1250	1093	1310	1121	1370	1149	1431	1178	1491	1206	1551	1235	1611	1263	1672	1292	1732	1320	1792	1348	1853	1377	1913	—	—	—	—	—	—	—	—							
2500 [1180]	—	—	—	—	—	—	—	969	1108	998	1169	1026	1229	1055	1289	1083	1350	1112	1410	1140	1470	1168	1531	1197	1591	1225	1651	1254	1711	1282	1772	1310	1832	1339	1892	1367	1953	1396	2013	—	—	—	—	—	—	—	—					
2600 [1227]	—	—	—	—	—	—	—	988	1208	1017	1269	1045	1329	1074	1389	1102	1450	1130	1510	1159	1570	1187	1631	1216	1691	1244	1751	1273	1811	1301	1872	1329	1932	1358	1992	1386	2053	—	—	—	—	—	—	—	—	—	—					
2700 [1274]	—	—	—	—	—	—	—	979	1248	1007	1308	1036	1369	1064	1429	1093	1489	1121	1550	1149	1610	1178	1670	1206	1731	1235	1791	1263	1851	1291	1911	1320	1972	1348	2032	1377	2092	—	—	—	—	—	—	—	—	—	—					
2800 [1321]	—	—	—	—	—	—	—	998	1348	1026	1408	1055	1469	1083	1529	1111	1589	1140	1650	1168	1710	1197	1770	1225	1831	1253	1891	1282	1951	1310	2011	1339	2072	1367	2132	1396	2192	—	—	—	—	—	—	—	—	—	—					
2900 [1369]	988	1388	1017	1448	1045	1508	1073	1569	1102	1629	1130	1689	1159	1750	1187	1810	1216	1870	1244	1931	1272	1991	1301	2051	1329	2111	1358	2172	1386	2232	—	—	—	—	—	—	—	—	—	—	—	—	—	—	—	—	—					
3000 [1416]	1007	1488	1036	1548	1064	1608	1092	1669	1121	1729	1149	1789	1178	1850	1206	1910	1234	1970	1263	2031	1291	2091	1320	2151	1348	2211	1377	2272	—	—	—	—	—	—	—	—	—	—	—	—	—	—	—	—	—	—	—	—				
3100 [1463]	1026	1588	1054	1648	1083	1708	1111	1769	1140	1829	1168	1889	1197	1950	1225	2010	1253	2070	1282	2131	1310	2191	1339	2251	1367	2311	1395	2372	—	—	—	—	—	—	—	—	—	—	—	—	—	—	—	—	—	—	—	—	—			
3200 [1510]	1045	1688	1073	1748	1102	1808	1130	1869	1159	1929	1187	1989	1215	2050	1244	2110	1272	2170	1301	2231	1329	2291	1357	2351	1386	2411	—	—	—	—	—	—	—	—	—	—	—	—	—	—	—	—	—	—	—	—	—	—	—	—		
3300 [1557]	1064	1788	1092	1848	1121	1908	1149	1969	1177	2029	1206	2089	1234	2150	1263	2210	1291	2270	1320	2331	1348	2391	1376	2451	—	—	—	—	—	—	—	—	—	—	—	—	—	—	—	—	—	—	—	—	—	—	—	—	—	—	—	
3400 [1605]	1083	1888	1111	1948	1140	2008	1168	2069	1196	2129	1225	2189	1253	2250	1282	2310	1310	2370	1338	2431	1367	2491	1395	2551	—	—	—	—	—	—	—	—	—	—	—	—	—	—	—	—	—	—	—	—	—	—	—	—	—	—	—	—

NOTE: L-Drive left of bold line, M-Drive right of bold line.

Drive Package	L						M														
Motor H.P. [W]	1 1/2 [1119]						1 1/2 [1119]														
Blower Sheave	AK66						AK59														
Motor Sheave	IVP-50						IVP-50														
Turns Open	0	1	2	3	4	5	6	0	1	2	3	4	5	6	0	1	2	3	4	5	6
RPM	1250	1222	1174	1165	1080	1033	966	1397	1341	1286	1228	1176	1121	1067							

NOTE: Factory sheave settings are shown in bold print.

COMPONENT AIR RESISTANCE

Component	Standard Indoor Airflow—CFM [L/s]			
	2200 [944]	2400 [1133]	2600 [1227]	2800 [1321]
Wet Coil	.079	.090	.102	.118
Downflow	.061	.079	.089	.100
Economizer R.A. Damper	.09	.10	.11	.12

NOTES:

- Performance shown with dry coil & standard 2" [50.8 mm] filters.
- Standard CFM @ .075 lbs./cu. ft.
- Motor efficiency = 80% on 208/230, 460, 575 V. 3-Phase
Motor efficiency = 50% on 208/230 V. 1-Phase
- BHP = $\frac{\text{Watts} \times \text{Motor Eff.}}{746}$
- Add component resistance to duct static to determine total E.S.P.

[] Designates Metric Conversions



ELECTRICAL DATA—RKKA- SERIES

Model No. RKKA-	Unit Information				Evaporator Fan					
	Unit Operating Voltage Range	Minimum Circuit Ampacity	Minimum Overcurrent Protection Device Size	Maximum Overcurrent Protection Device Size	No.	Volts	Phase	HP	Amps (FLA)	Amps (LRA)
A036CK08E	187-253	21/21	25/25	30/30	1	208/230	3	1/2	3	6.5
A036CK12E	187-253	21/21	25/25	30/30	1	208/230	3	1/2	3	6.5
A036CL08E	187-253	21/21	25/25	30/30	1	208/230	3	1/2	2.8	11
A036CL12E	187-253	21/21	25/25	30/30	1	208/230	3	1/2	2.8	11
A036CM08E	187-253	21/21	25/25	30/30	1	208/230	3	1/2	2.8	11
A036CM12E	187-253	21/21	25/25	30/30	1	208/230	3	1/2	2.8	11
A036DK08E	414-506	11	15	15	1	460	3	1/2	2	3.6
A036DK12E	414-506	11	15	15	1	460	3	1/2	2	3.6
A036DL08E	414-506	11	15	15	1	460	3	1/2	1.4	5.5
A036DL12E	414-506	11	15	15	1	460	3	1/2	1.4	5.5
A036DM08E	414-506	11	15	15	1	460	3	1/2	1.4	5.5
A036DM12E	414-506	11	15	15	1	460	3	1/2	1.4	5.5
A036YL08E	518-633	8	15	15	1	575	3	1/2	1.3	6
A036YL12E	518-633	8	15	15	1	575	3	1/2	1.3	6
A036YM08E	518-633	8	15	15	1	575	3	1/2	1.3	6
A036YM12E	518-633	8	15	15	1	575	3	1/2	1.3	6
A042CK08E	187-253	22/22	30/30	35/35	1	208/230	3	1/2	3	6.5
A042CK12E	187-253	22/22	30/30	35/35	1	208/230	3	1/2	3	6.5
A042CL08E	187-253	22/22	30/30	35/35	1	208/230	3	1/2	2.8	11
A042CL12E	187-253	22/22	30/30	35/35	1	208/230	3	1/2	2.8	11
A042CM08E	187-253	22/22	30/30	35/35	1	208/230	3	1/2	2.8	11
A042CM12E	187-253	22/22	30/30	35/35	1	208/230	3	1/2	2.8	11
A042DK08E	414-506	13	15	15	1	460	3	1/2	2	3.6
A042DK12E	414-506	13	15	15	1	460	3	1/2	2	3.6
A042DL08E	414-506	12	15	15	1	460	3	1/2	1.4	5.5
A042DL12E	414-506	12	15	15	1	460	3	1/2	1.4	5.5
A042DM08E	414-506	12	15	15	1	460	3	1/2	1.4	5.5
A042DM12E	414-506	12	15	15	1	460	3	1/2	1.4	5.5
A042YL08E	518-633	10	15	15	1	575	3	1/2	1.3	6
A042YL12E	518-633	10	15	15	1	575	3	1/2	1.3	6
A042YM08E	518-633	10	15	15	1	575	3	1/2	1.3	6
A042YM12E	518-633	10	15	15	1	575	3	1/2	1.3	6

CONTINUED →



Model No. RKKA-	Unit Information				Evaporator Fan					
	Unit Operating Voltage Range	Minimum Circuit Ampacity	Minimum Overcurrent Protection Device Size	Maximum Overcurrent Protection Device Size	No.	Volts	Phase	HP	Amps (FLA)	Amps (LRA)
A048CK08E	187-253	22/22	30/30	35/35	1	208/230	3	1/2	3	6.5
A048CK10E	187-253	22/22	30/30	35/35	1	208/230	3	1/2	3	6.5
A048CK13E	187-253	22/22	30/30	35/35	1	208/230	3	1/2	3	6.5
A048CL08E	187-253	22/22	30/30	35/35	1	208/230	3	1/2	2.8	11
A048CL10E	187-253	22/22	30/30	35/35	1	208/230	3	1/2	2.8	11
A048CL13E	187-253	22/22	30/30	35/35	1	208/230	3	1/2	2.8	11
A048CM08E	187-253	23/23	30/30	35/35	1	208/230	3	3/4	2.6	16.8
A048CM10E	187-253	23/23	30/30	35/35	1	208/230	3	3/4	2.6	16.8
A048CM13E	187-253	23/23	30/30	35/35	1	208/230	3	3/4	2.6	16.8
A048DK08E	414-506	12	15	15	1	460	3	1/2	2	3.6
A048DK10E	414-506	12	15	15	1	460	3	1/2	2	3.6
A048DK13E	414-506	12	15	15	1	460	3	1/2	2	3.6
A048DL08E	414-506	12	15	15	1	460	3	1/2	1.4	5.5
A048DL10E	414-506	12	15	15	1	460	3	1/2	1.4	5.5
A048DL13E	414-506	12	15	15	1	460	3	1/2	1.4	5.5
A048DM08E	414-506	12	15	15	1	460	3	3/4	1.3	8.4
A048DM10E	414-506	12	15	15	1	460	3	3/4	1.3	8.4
A048DM13E	414-506	12	15	15	1	460	3	3/4	1.3	8.4
A048YL08E	518-633	10	15	15	1	575	3	1/2	1.3	6
A048YL10E	518-633	10	15	15	1	575	3	1/2	1.3	6
A048YL13E	518-633	10	15	15	1	575	3	1/2	1.3	6
A048YM08E	518-633	10	15	15	1	575	3	1/2	1.3	6
A048YM10E	518-633	10	15	15	1	575	3	1/2	1.3	6
A048YM13E	518-633	10	15	15	1	575	3	1/2	1.3	6

CONTINUED →



ELECTRICAL DATA—RKKA- SERIES

Model No. RKKA-	Unit Information				Evaporator Fan					
	Unit Operating Voltage Range	Minimum Circuit Ampacity	Minimum Overcurrent Protection Device Size	Maximum Overcurrent Protection Device Size	No.	Volts	Phase	HP	Amps (FLA)	Amps (LRA)
A060CK10E	187-253	30/30	35/35	40/40	1	208/230	3	3/4	5.4	12
A060CK13E	187-253	30/30	35/35	40/40	1	208/230	3	3/4	5.4	12
A060CL10E	187-253	28/28	35/35	40/40	1	208/230	3	3/4	2.6	16.8
A060CL13E	187-253	28/28	35/35	40/40	1	208/230	3	3/4	2.6	16.8
A060CM10E	187-253	28/28	35/35	40/40	1	208/230	3	1	3.2	24
A060CM13E	187-253	28/28	35/35	40/40	1	208/230	3	1	3.2	24
A060DK10E	414-506	15	20	20	1	460	3	3/4	2.7	12
A060DK13E	414-506	15	20	20	1	460	3	3/4	2.7	12
A060DL10E	414-506	14	20	20	1	460	3	3/4	1.3	8.4
A060DL13E	414-506	14	20	20	1	460	3	3/4	1.3	8.4
A060DM10E	414-506	15	20	20	1	460	3	1	1.6	12
A060DM13E	414-506	15	20	20	1	460	3	1	1.6	12
A060YL10E	518-633	11	15	15	1	575	3	3/4	1.3	6
A060YL13E	518-633	11	15	15	1	575	3	3/4	1.3	6
A060YM10E	518-633	11	15	15	1	575	3	1	1.4	7.2
A060YM13E	518-633	11	15	15	1	575	3	1	1.4	7.2
A073CL10E	187-253	37/37	40/40	50/50	1	208/230	3	1 1/2	5.8	28.8
A073CL13E	187-253	37/37	40/40	50/50	1	208/230	3	1 1/2	5.8	28.8
A073CM10E	187-253	37/37	40/40	50/50	1	208/230	3	1 1/2	5.8	28.8
A073CM13E	187-253	37/37	40/40	50/50	1	208/230	3	1 1/2	5.8	28.8
A073DL10E	414-506	19	20	25	1	460	3	1 1/2	2.8	14.4
A073DL13E	414-506	19	20	25	1	460	3	1 1/2	2.8	14.4
A073DM10E	414-506	19	20	25	1	460	3	1 1/2	2.8	14.4
A073DM13E	414-506	19	20	25	1	460	3	1 1/2	2.8	14.4
A073YL10E	518-633	15	15	20	1	575	3	1 1/2	2.3	13
A073YL13E	518-633	15	15	20	1	575	3	1 1/2	2.3	13
A073YM10E	518-633	15	15	20	1	575	3	1 1/2	2.3	13
A073YM13E	518-633	15	15	20	1	575	3	1 1/2	2.3	13
A085CL13E	187-253	39/39	40/40	50/50	1	208/230	3	1 1/2	5.8	28.8
A085CL13T	187-253	39/39	40/40	50/50	1	208/230	3	1 1/2	5.8	28.8
A085CM13E	187-253	39/39	40/40	50/50	1	208/230	3	1 1/2	5.8	28.8
A085CM13T	187-253	39/39	40/40	50/50	1	208/230	3	1 1/2	5.8	28.8
A085DL13E	414-506	20	20	25	1	460	3	1 1/2	2.8	14.4
A085DL13T	414-506	20	20	25	1	460	3	1 1/2	2.8	14.4
A085DM13E	414-506	20	20	25	1	460	3	1 1/2	2.8	14.4
A085DM13T	414-506	20	20	25	1	460	3	1 1/2	2.8	14.4
A085YL13E	518-633	16	15	20	1	575	3	1 1/2	2.3	13
A085YL13T	518-633	16	15	20	1	575	3	1 1/2	2.3	13
A085YM13E	518-633	16	15	20	1	575	3	1 1/2	2.3	13
A085YM13T	518-633	16	15	20	1	575	3	1 1/2	2.3	13



Model No. RKKA-	Compressor Motor							Condenser Motor					
	No.	Volts	Phase	HP ²	RPM	Amps ¹ (RLA)	Amps ¹ (LRA)	No.	Volts	Phase	HP ²	Amps ¹ (FLA)	Amps ¹ (LRA)
A036CK08E	1	208/230	3	3 1/3	3450	12.4/12.4	88/88	1	208/230	1	1/3	2	4.7
A036CK12E	1	208/230	3	3 1/3	3450	12.4/12.4	88/88	1	208/230	1	1/3	2	4.7
A036CL08E	1	208/230	3	3 1/3	3450	12.4/12.4	88/88	1	208/230	1	1/3	2	4.7
A036CL12E	1	208/230	3	3 1/3	3450	12.4/12.4	88/88	1	208/230	1	1/3	2	4.7
A036CM08E	1	208/230	3	3 1/3	3450	12.4/12.4	88/88	1	208/230	1	1/3	2	4.7
A036CM12E	1	208/230	3	3 1/3	3450	12.4/12.4	88/88	1	208/230	1	1/3	2	4.7
A036DK08E	1	460	3	3 1/3	3450	6.1	44	1	460	1	1/3	1	2.4
A036DK12E	1	460	3	3 1/3	3450	6.1	44	1	460	1	1/3	1	2.4
A036DL08E	1	460	3	3 1/3	3450	6.1	44	1	460	1	1/3	1	2.4
A036DL12E	1	460	3	3 1/3	3450	6.1	44	1	460	1	1/3	1	2.4
A036DM08E	1	460	3	3 1/3	3450	6.1	44	1	460	1	1/3	1	2.4
A036DM12E	1	460	3	3 1/3	3450	6.1	44	1	460	1	1/3	1	2.4
A036YL08E	1	575	3	3 1/3	3450	4.8	35	1	575	1	1/3	0.7	1.5
A036YL12E	1	575	3	3 1/3	3450	4.8	35	1	575	1	1/3	0.7	1.5
A036YM08E	1	575	3	3 1/3	3450	4.8	35	1	575	1	1/3	0.7	1.5
A036YM12E	1	575	3	3 1/3	3450	4.8	35	1	575	1	1/3	0.7	1.5
A042CK08E	1	208/230	3	3 1/2	3450	14/14	88/88	1	208/230	1	1/3	2	4.7
A042CK12E	1	208/230	3	3 1/2	3450	14/14	88/88	1	208/230	1	1/3	2	4.7
A042CL08E	1	208/230	3	3 1/2	3450	14/14	88/88	1	208/230	1	1/3	2	4.7
A042CL12E	1	208/230	3	3 1/2	3450	14/14	88/88	1	208/230	1	1/3	2	4.7
A042CM08E	1	208/230	3	3 1/2	3450	14/14	88/88	1	208/230	1	1/3	2	4.7
A042CM12E	1	208/230	3	3 1/2	3450	14/14	88/88	1	208/230	1	1/3	2	4.7
A042DK08E	1	460	3	3 1/2	3450	7.2	44	1	460	1	1/3	1	2.4
A042DK12E	1	460	3	3 1/2	3450	7.2	44	1	460	1	1/3	1	2.4
A042DL08E	1	460	3	3 1/2	3450	7.2	44	1	460	1	1/3	1	2.4
A042DL12E	1	460	3	3 1/2	3450	7.2	44	1	460	1	1/3	1	2.4
A042DM08E	1	460	3	3 1/2	3450	7.2	44	1	460	1	1/3	1	2.4
A042DM12E	1	460	3	3 1/2	3450	7.2	44	1	460	1	1/3	1	2.4
A042YL08E	1	575	3	3 1/2	3450	5.4	34	1	575	1	1/3	0.7	1.5
A042YL12E	1	575	3	3 1/2	3450	5.4	34	1	575	1	1/3	0.7	1.5
A042YM08E	1	575	3	3 1/2	3450	5.4	34	1	575	1	1/3	0.7	1.5
A042YM12E	1	575	3	3 1/2	3450	5.4	34	1	575	1	1/3	0.7	1.5

CONTINUED →

1. Horsepower Per Compressor.
 2. Amp Draw Per Motor. Multiply Value By Number of Motors to Determine Total Amps.



Model No. RKKA-	Compressor Motor							Condenser Motor					
	No.	Volts	Phase	HP ²	RPM	Amps ¹ (RLA)	Amps ¹ (LRA)	No.	Volts	Phase	HP ²	Amps ¹ (FLA)	Amps ¹ (LRA)
A048CK08E	1	208/230	3	4	3450	16.4/16.4	91/91	1	208/230	1	1/3	2	4.7
A048CK10E	1	208/230	3	4	3450	16.4/16.4	91/91	1	208/230	1	1/3	2	4.7
A048CK13E	1	208/230	3	4	3450	16.4/16.4	91/91	1	208/230	1	1/3	2	4.7
A048CL08E	1	208/230	3	4	3450	16.4/16.4	91/91	1	208/230	1	1/3	2	4.7
A048CL10E	1	208/230	3	4	3450	16.4/16.4	91/91	1	208/230	1	1/3	2	4.7
A048CL13E	1	208/230	3	4	3450	16.4/16.4	91/91	1	208/230	1	1/3	2	4.7
A048CM08E	1	208/230	3	4	3450	16.4/16.4	91/91	1	208/230	1	1/3	2	4.7
A048CM10E	1	208/230	3	4	3450	16.4/16.4	91/91	1	208/230	1	1/3	2	4.7
A048CM13E	1	208/230	3	4	3450	16.4/16.4	91/91	1	208/230	1	1/3	2	4.7
A048DK08E	1	460	3	4	3450	7.4	50	1	460	1	1/3	1	2.4
A048DK10E	1	460	3	4	3450	7.4	50	1	460	1	1/3	1	2.4
A048DK13E	1	460	3	4	3450	7.4	50	1	460	1	1/3	1	2.4
A048DL08E	1	460	3	4	3450	7.4	50	1	460	1	1/3	1	2.4
A048DL10E	1	460	3	4	3450	7.4	50	1	460	1	1/3	1	2.4
A048DL13E	1	460	3	4	3450	7.4	50	1	460	1	1/3	1	2.4
A048DM08E	1	460	3	4	3450	7.4	50	1	460	1	1/3	1	2.4
A048DM10E	1	460	3	4	3450	7.4	50	1	460	1	1/3	1	2.4
A048DM13E	1	460	3	4	3450	7.4	50	1	460	1	1/3	1	2.4
A048YL08E	1	575	3	4	3450	5.8	40	1	575	1	1/3	0.7	1.5
A048YL10E	1	575	3	4	3450	5.8	40	1	575	1	1/3	0.7	1.5
A048YL13E	1	575	3	4	3450	5.8	40	1	575	1	1/3	0.7	1.5
A048YM08E	1	575	3	4	3450	5.8	40	1	575	1	1/3	0.7	1.5
A048YM10E	1	575	3	4	3450	5.8	40	1	575	1	1/3	0.7	1.5
A048YM13E	1	575	3	4	3450	5.8	40	1	575	1	1/3	0.7	1.5

1. Horsepower Per Compressor.
2. Amp Draw Per Motor. Multiply Value By Number of Motors to Determine Total Amps.

CONTINUED →



Model No. RKKA-	Compressor Motor							Condenser Motor					
	No.	Volts	Phase	HP ²	RPM	Amps ¹ (RLA)	Amps ¹ (LRA)	No.	Volts	Phase	HP ²	Amps ¹ (FLA)	Amps ¹ (LRA)
A060CK10E	1	208/230	3	5	3450	17.3/17.3	137/137	1	208/230	1	1/3	2	4.7
A060CK13E	1	208/230	3	5	3450	17.3/17.3	137/137	1	208/230	1	1/3	2	4.7
A060CL10E	1	208/230	3	5	3450	17.3/17.3	137/137	1	208/230	1	1/3	2	4.7
A060CL13E	1	208/230	3	5	3450	17.3/17.3	137/137	1	208/230	1	1/3	2	4.7
A060CM10E	1	208/230	3	5	3450	17.3/17.3	137/137	1	208/230	1	1/3	2	4.7
A060CM13E	1	208/230	3	5	3450	17.3/17.3	137/137	1	208/230	1	1/3	2	4.7
A060DK10E	1	460	3	5	3450	9	62	1	460	1	1/3	1	2.4
A060DK13E	1	460	3	5	3450	9	62	1	460	1	1/3	1	2.4
A060DL10E	1	460	3	5	3450	9	62	1	460	1	1/3	1	2.4
A060DL13E	1	460	3	5	3450	9	62	1	460	1	1/3	1	2.4
A060DM10E	1	460	3	5	3450	9	62	1	460	1	1/3	1	2.4
A060DM13E	1	460	3	5	3450	9	62	1	460	1	1/3	1	2.4
A060YL10E	1	575	3	5	3450	7.1	50	1	575	1	1/3	0.7	1.5
A060YL13E	1	575	3	5	3450	7.1	50	1	575	1	1/3	0.7	1.5
A060YM10E	1	575	3	5	3450	7.1	50	1	575	1	1/3	0.7	1.5
A060YM13E	1	575	3	5	3450	7.1	50	1	575	1	1/3	0.7	1.5
A073CL10E	1	208/230	3	6	3450	21.9/21.9	156/156	1	208/230	1	1/3	2.6	4.7
A073CL13E	1	208/230	3	6	3450	21.9/21.9	156/156	1	208/230	1	1/3	2.6	4.7
A073CM10E	1	208/230	3	6	3450	21.9/21.9	156/156	1	208/230	1	1/3	2.6	4.7
A073CM13E	1	208/230	3	6	3450	21.9/21.9	156/156	1	208/230	1	1/3	2.6	4.7
A073DL10E	1	460	3	6	3450	10.9	75	1	460	1	1/3	1.2	2.4
A073DL13E	1	460	3	6	3450	10.9	75	1	460	1	1/3	1.2	2.4
A073DM10E	1	460	3	6	3450	10.9	75	1	460	1	1/3	1.2	2.4
A073DM13E	1	460	3	6	3450	10.9	75	1	460	1	1/3	1.2	2.4
A073YL10E	1	575	3	6	3450	8.9	54	1	575	1	1/3	0.9	1.5
A073YL13E	1	575	3	6	3450	8.9	54	1	575	1	1/3	0.9	1.5
A073YM10E	1	575	3	6	3450	8.9	54	1	575	1	1/3	0.9	1.5
A073YM13E	1	575	3	6	3450	8.9	54	1	575	1	1/3	0.9	1.5
A085CL13E	2	208/230	3	3 1/2	3450	14/14	88/88	1	208/230	1	1/3	2.6	4.7
A085CL13T	2	208/230	3	3 1/2	3450	14/14	88/88	1	208/230	1	1/3	2.6	4.7
A085CM13E	2	208/230	3	3 1/2	3450	14/14	88/88	1	208/230	1	1/3	2.6	4.7
A085CM13T	2	208/230	3	3 1/2	3450	14/14	88/88	1	208/230	1	1/3	2.6	4.7
A085DL13E	2	460	3	3 1/2	3450	7.2	44	1	460	1	1/3	1.2	2.4
A085DL13T	2	460	3	3 1/2	3450	7.2	44	1	460	1	1/3	1.2	2.4
A085DM13E	2	460	3	3 1/2	3450	7.2	44	1	460	1	1/3	1.2	2.4
A085DM13T	2	460	3	3 1/2	3450	7.2	44	1	460	1	1/3	1.2	2.4
A085YL13E	2	575	3	3 1/2	3450	5.4	34	1	575	1	1/3	0.9	1.5
A085YL13T	2	575	3	3 1/2	3450	5.4	34	1	575	1	1/3	0.9	1.5
A085YM13E	2	575	3	3 1/2	3450	5.4	34	1	575	1	1/3	0.9	1.5
A085YM13T	2	575	3	3 1/2	3450	5.4	34	1	575	1	1/3	0.9	1.5

1. Horsepower Per Compressor.

2. Amp Draw Per Motor. Multiply Value By Number of Motors to Determine Total Amps.



ELECTRICAL DATA—RKMA- SERIES

Model No. RKMA-	Unit Information				Evaporator Fan					
	Unit Operating Voltage Range	Minimum Circuit Ampacity	Minimum Overcurrent Protection Device Size	Maximum Overcurrent Protection Device Size	No.	Volts	Phase	HP	Amps (FLA)	Amps (LRA)
A072CL10E	187-253	34/34	40/40	40/40	1	208/230	3	1 1/2	5.8	28.8
A072CL13E	187-253	34/34	40/40	40/40	1	208/230	3	1 1/2	5.8	28.8
A072CM10E	187-253	34/34	40/40	40/40	1	208/230	3	1 1/2	5.8	28.8
A072CM13E	187-253	34/34	40/40	40/40	1	208/230	3	1 1/2	5.8	28.8
A072DL10E	414-506	18	20	20	1	460	3	1 1/2	2.8	14.4
A072DL13E	414-506	18	20	20	1	460	3	1 1/2	2.8	14.4
A072DM10E	414-506	18	20	20	1	460	3	1 1/2	2.8	14.4
A072DM13E	414-506	18	20	20	1	460	3	1 1/2	2.8	14.4
A072YL10E	518-633	14	15	15	1	575	3	1 1/2	2.3	13
A072YL13E	518-633	14	15	15	1	575	3	1 1/2	2.3	13
A072YM10E	518-633	14	15	15	1	575	3	1 1/2	2.3	13
A072YM13E	518-633	14	15	15	1	575	3	1 1/2	2.3	13



Model No. RKMA-	Compressor Motor							Condenser Motor					
	No.	Volts	Phase	HP ²	RPM	Amps ¹ (RLA)	Amps ¹ (LRA)	No.	Volts	Phase	HP ²	Amps ¹ (FLA)	Amps ¹ (LRA)
A072CL10E	2	208/230	3	2 5/6	3450	11.4/11.4	77/77	1	208/230	1	1/3	2.6	4.7
A072CL13E	2	208/230	3	2 5/6	3450	11.4/11.4	77/77	1	208/230	1	1/3	2.6	4.7
A072CM10E	2	208/230	3	2 5/6	3450	11.4/11.4	77/77	1	208/230	1	1/3	2.6	4.7
A072CM13E	2	208/230	3	2 5/6	3450	11.4/11.4	77/77	1	208/230	1	1/3	2.6	4.7
A072DL10E	2	460	3	2 5/6	3450	5.9	39	1	460	1	1/3	1	1.9
A072DL13E	2	460	3	2 5/6	3450	5.9	39	1	460	1	1/3	1	1.9
A072DM10E	2	460	3	2 5/6	3450	5.9	39	1	460	1	1/3	1	1.9
A072DM13E	2	460	3	2 5/6	3450	5.9	39	1	460	1	1/3	1	1.9
A072YL10E	2	575	3	2 5/6	3450	4.7	31	1	575	1	1/3	0.9	1.5
A072YL13E	2	575	3	2 5/6	3450	4.7	31	1	575	1	1/3	0.9	1.5
A072YM10E	2	575	3	2 5/6	3450	4.7	31	1	575	1	1/3	0.9	1.5
A072YM13E	2	575	3	2 5/6	3450	4.7	31	1	575	1	1/3	0.9	1.5

1. Horsepower Per Compressor.

2. Amp Draw Per Motor. Multiply Value By Number of Motors to Determine Total Amps.



UNIT DIMENSIONS—RKKA/RKMA- SERIES

UNIT DIMENSIONS GAS HEAT / ELECTRIC COOLING PACKAGE

RKKA 3 TO 6 TON [10.6 TO 21.1 kW] MODELS

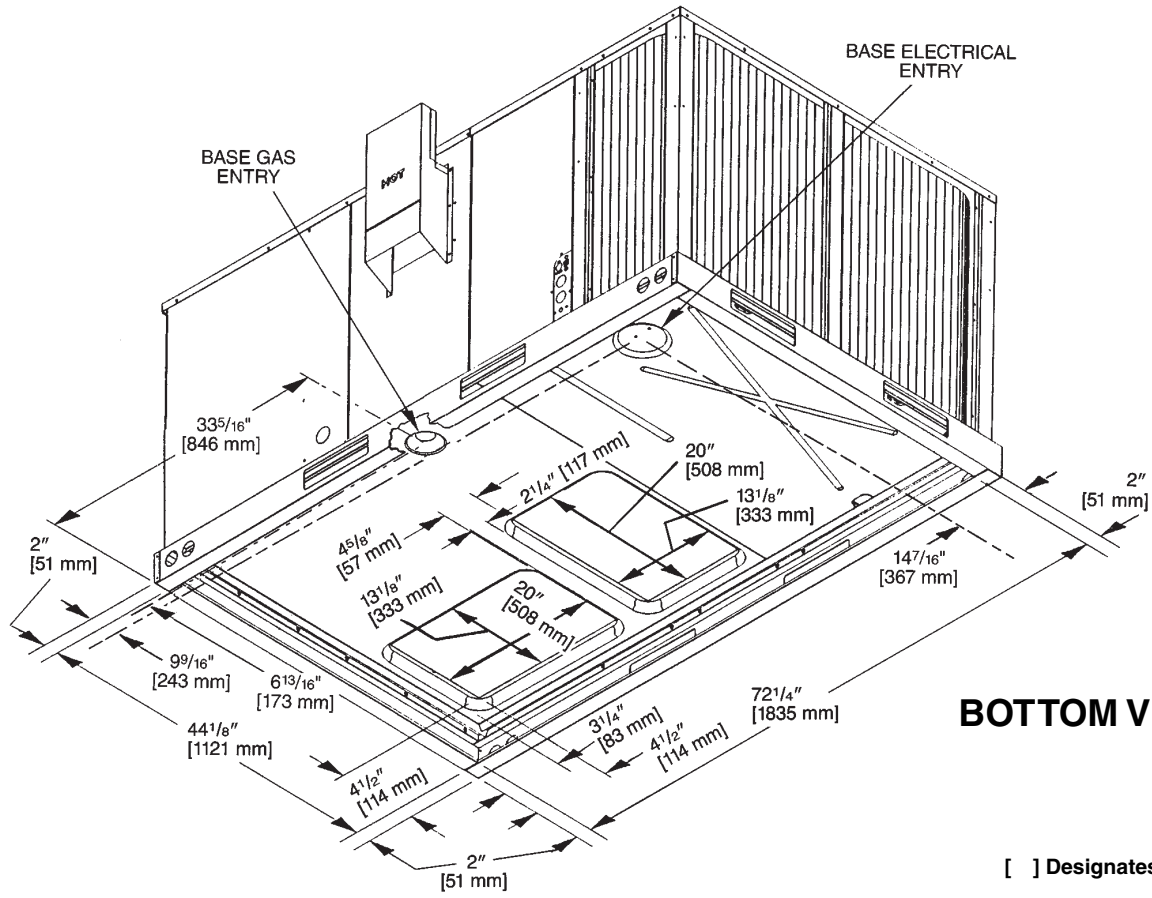
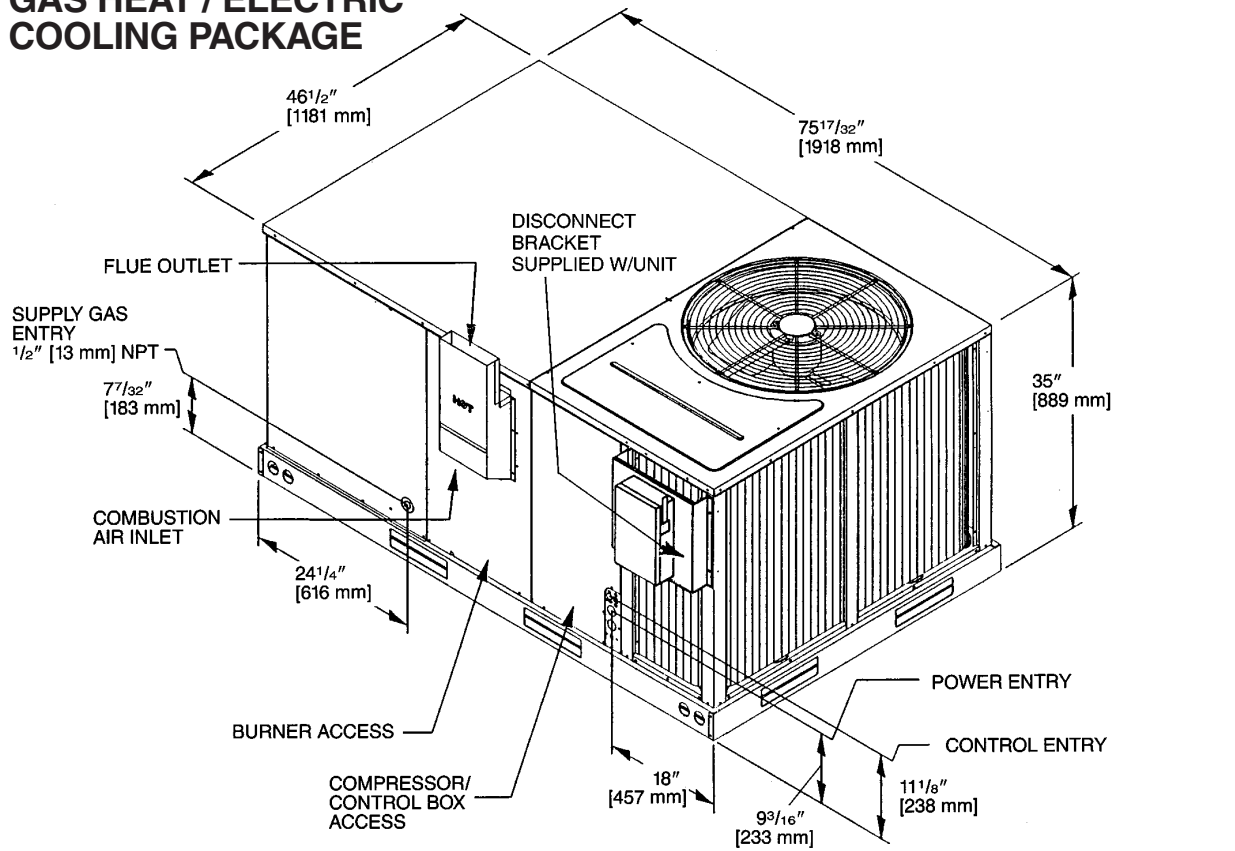

BOTTOM VIEW

[] Designates Metric Conversions

UNIT DIMENSIONS GAS HEAT / ELECTRIC COOLING PACKAGE

RKKA 3 TO 6 TON [10.6 TO 21.1 kW] MODELS

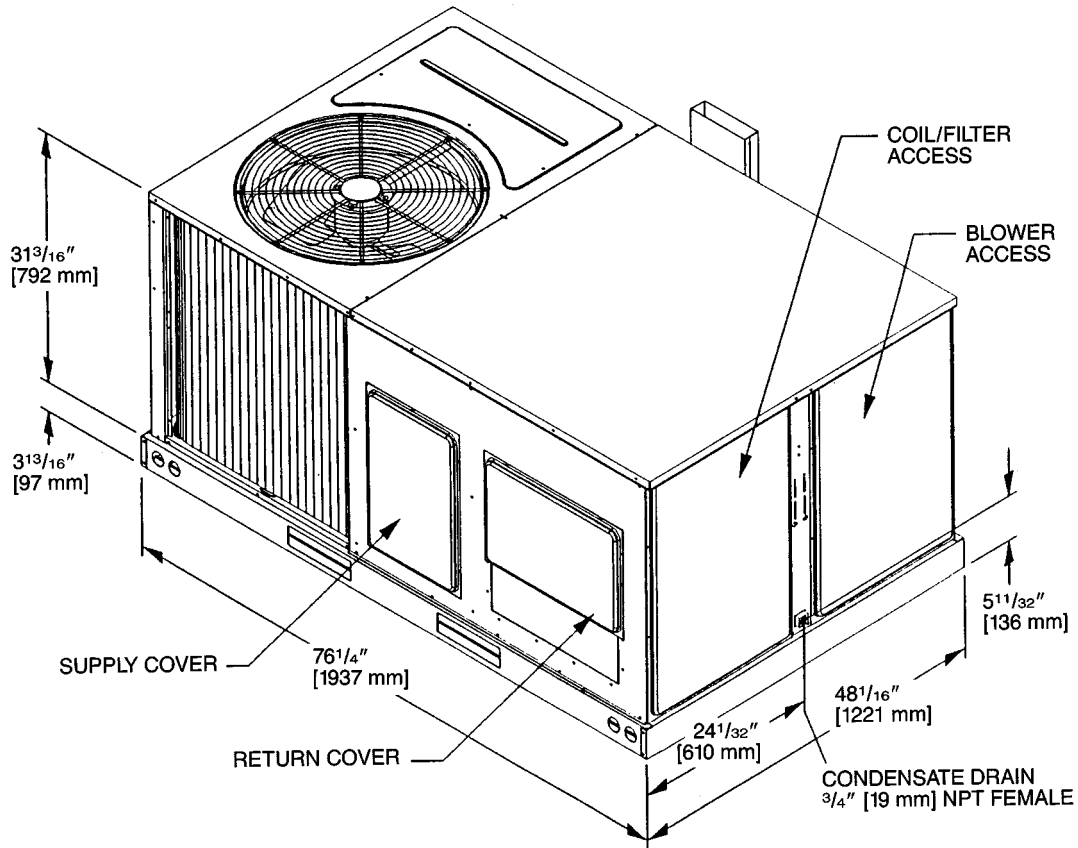

SUPPLY AND RETURN DIMENSIONS

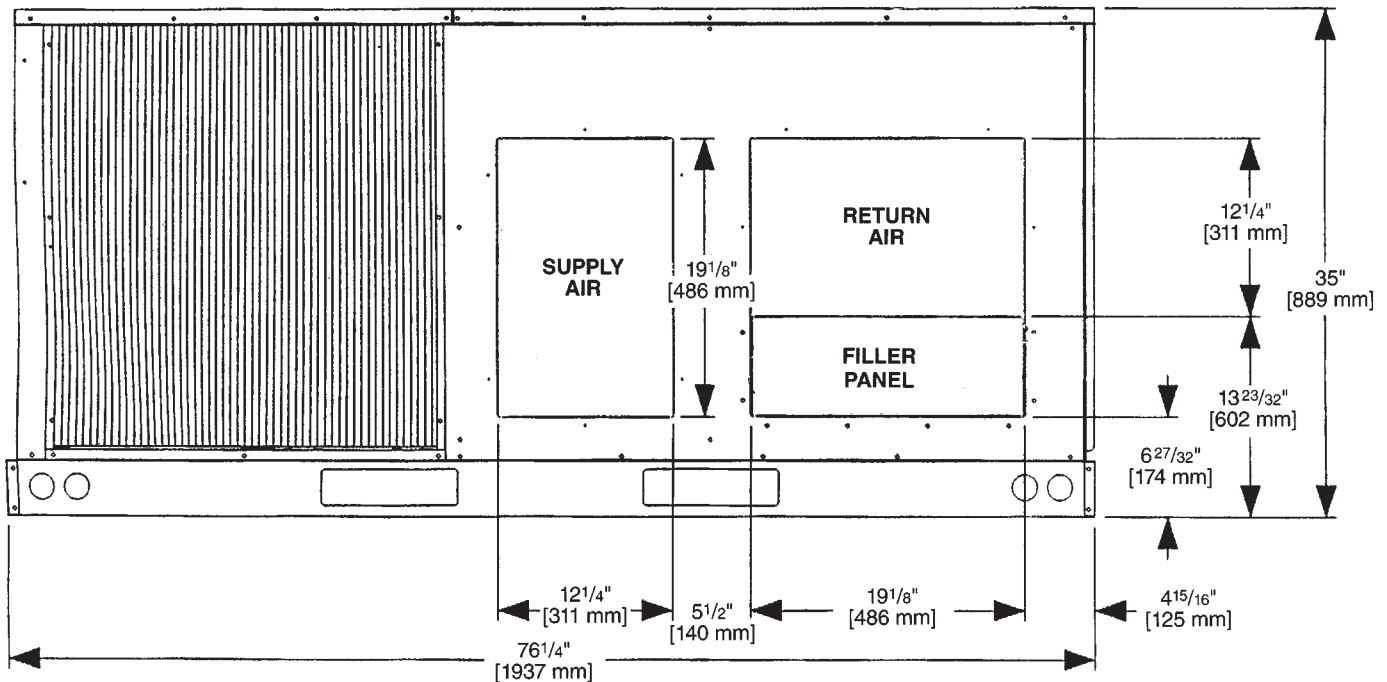

[] Designates Metric Conversions



UNIT DIMENSIONS—RKKA/RKMA- SERIES

UNIT DIMENSIONS GAS HEAT / ELECTRIC COOLING PACKAGE

RKKA 7.5 TON [26.4 kW] MODELS RKMA 6 TON [21.1 kW] MODELS

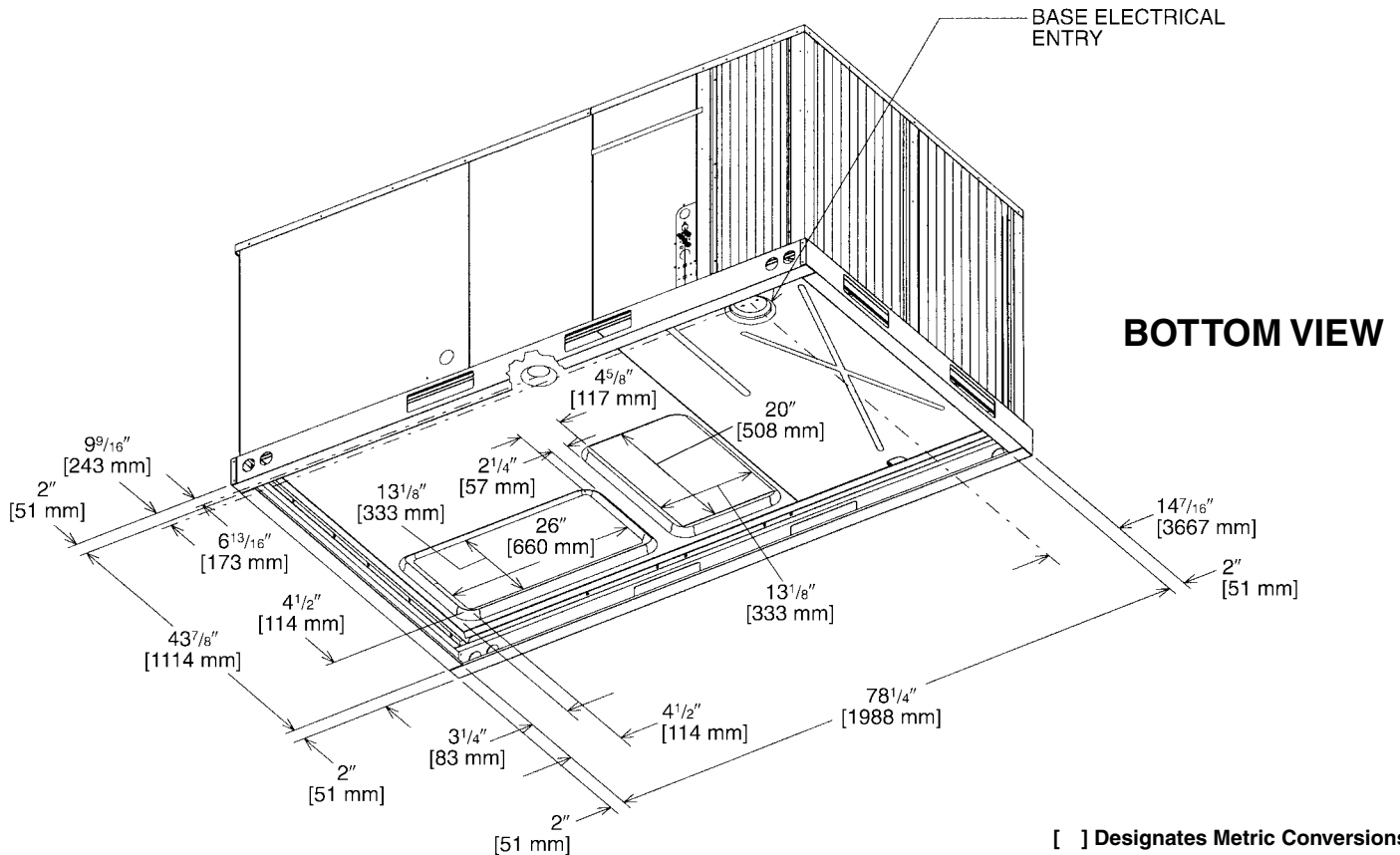
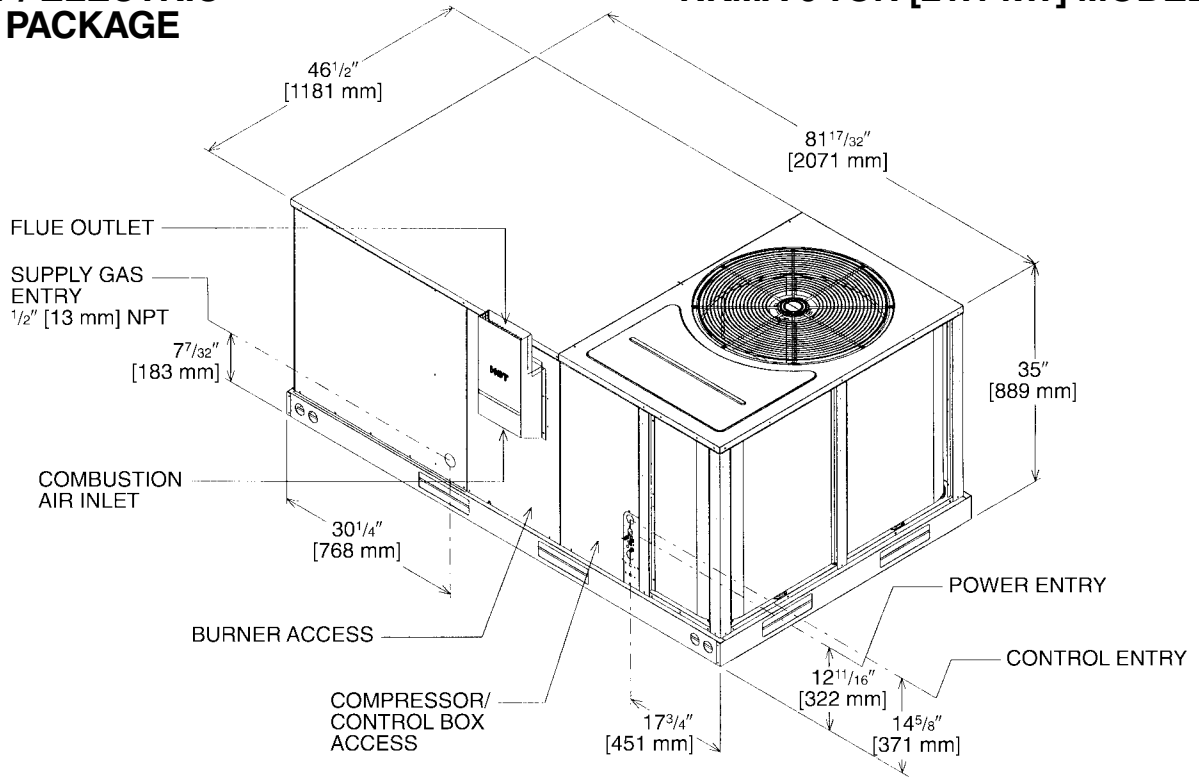

BOTTOM VIEW

[] Designates Metric Conversions

UNIT DIMENSIONS GAS HEAT / ELECTRIC COOLING PACKAGE

RKKA 7.5 TON [26.4 kW] MODELS RKMA 6 TON [21.1 kW] MODELS

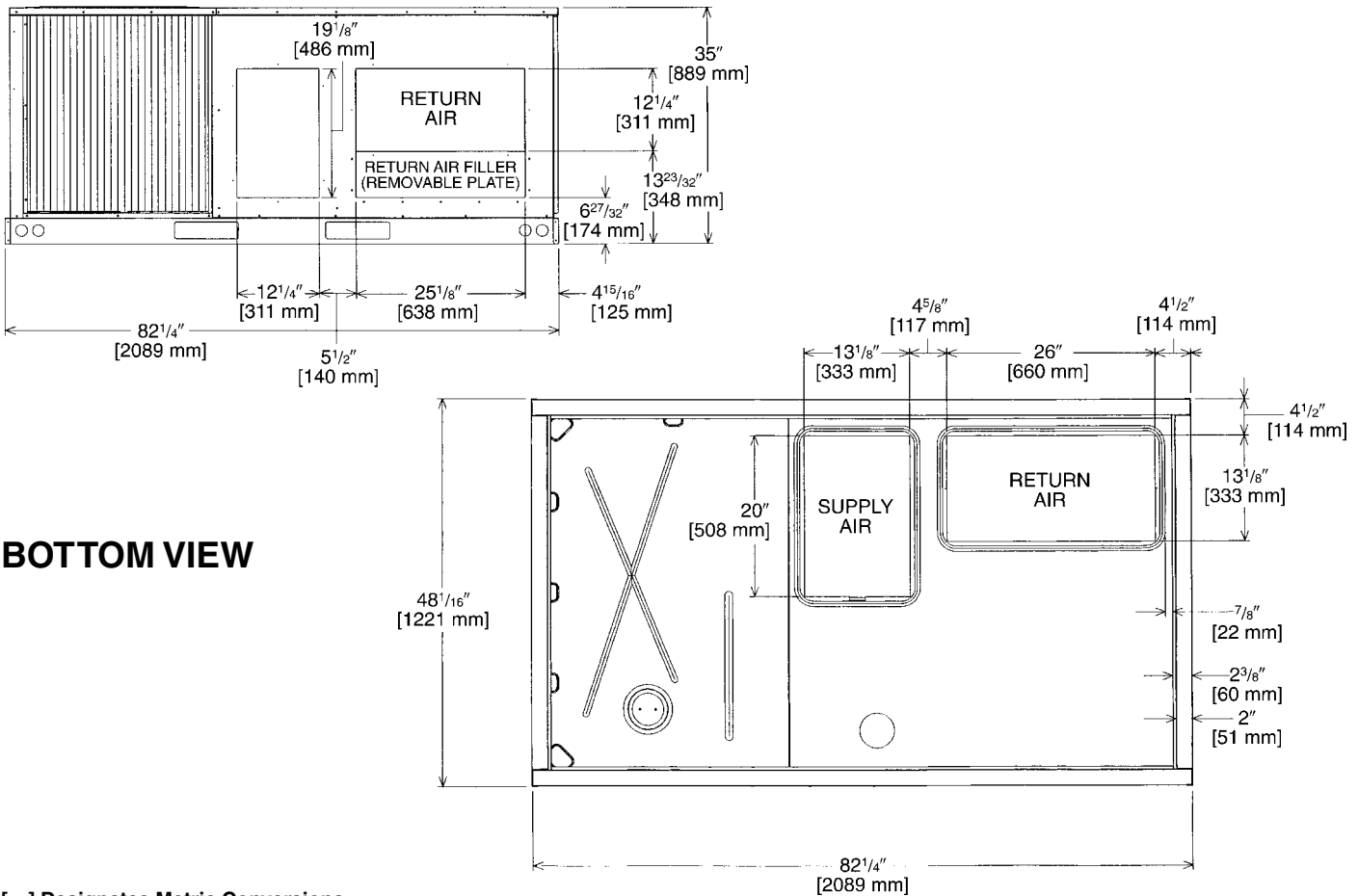
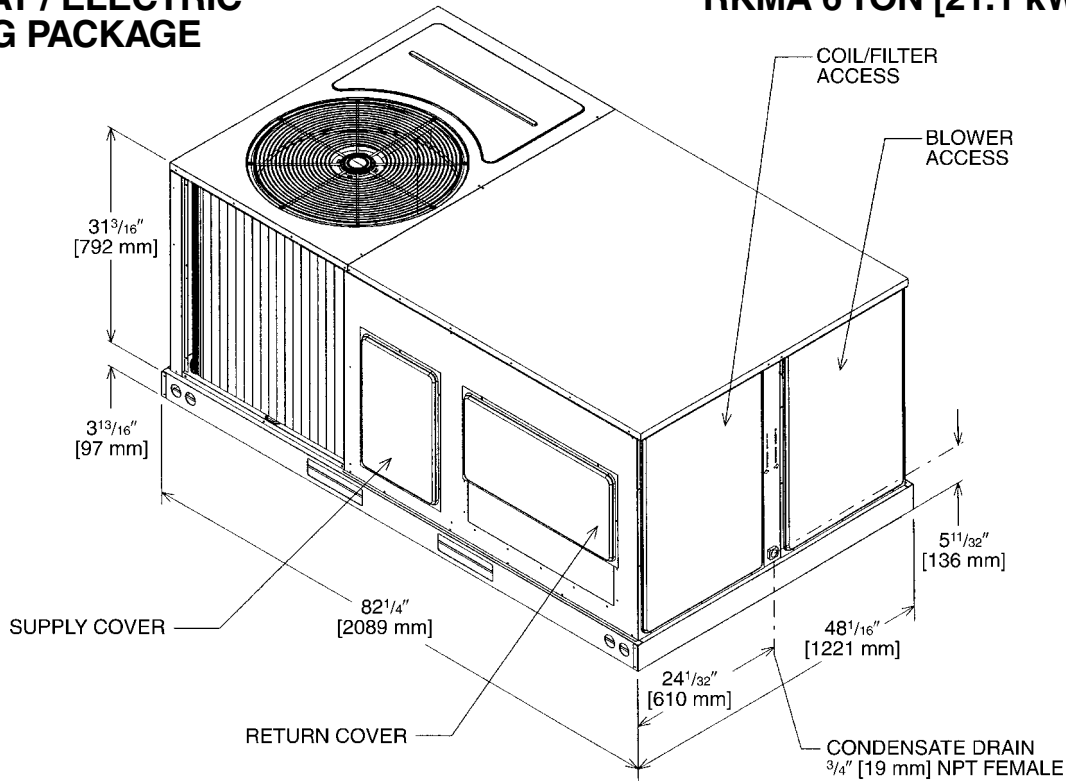

BOTTOM VIEW

[] Designates Metric Conversions



UNIT DIMENSIONS—RKKA/RKMA- SERIES

UNIT DIMENSIONS GAS HEAT / ELECTRIC COOLING PACKAGE

RKKA 7.5 TON [26.4 kW] MODELS RKMA 6 TON [21.1 kW] MODELS

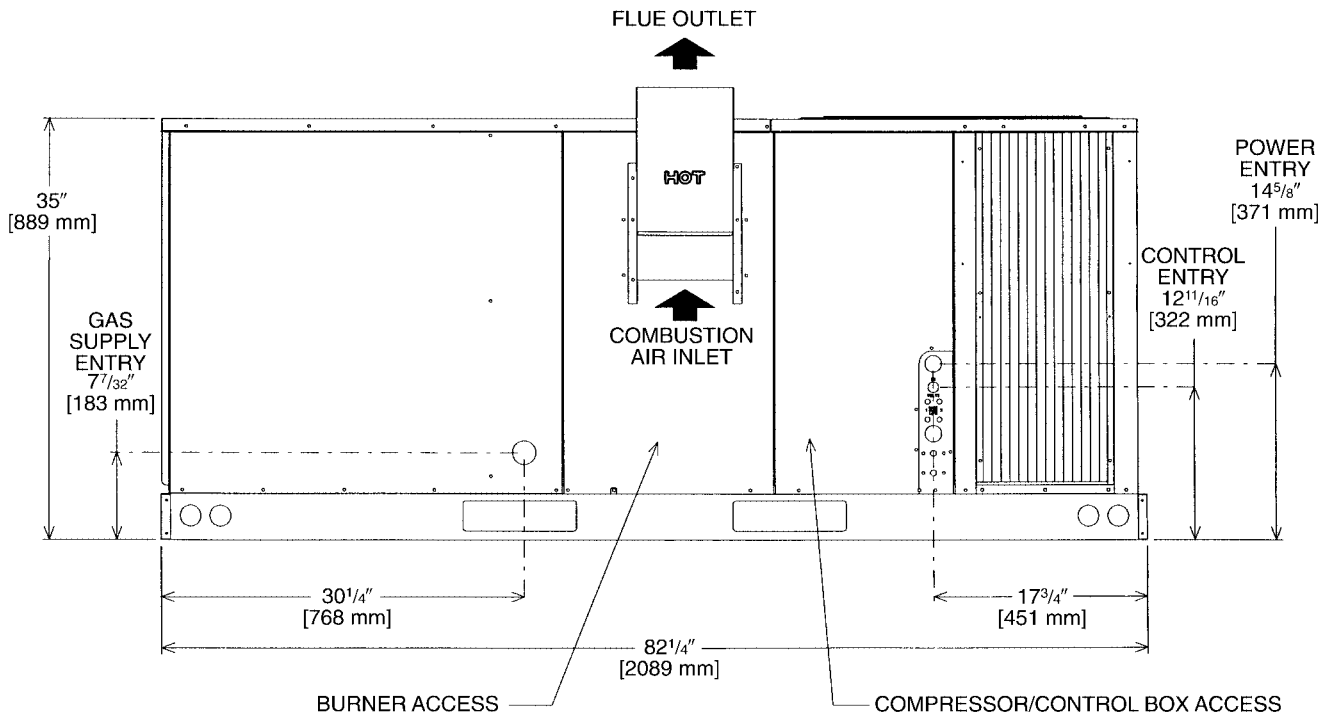
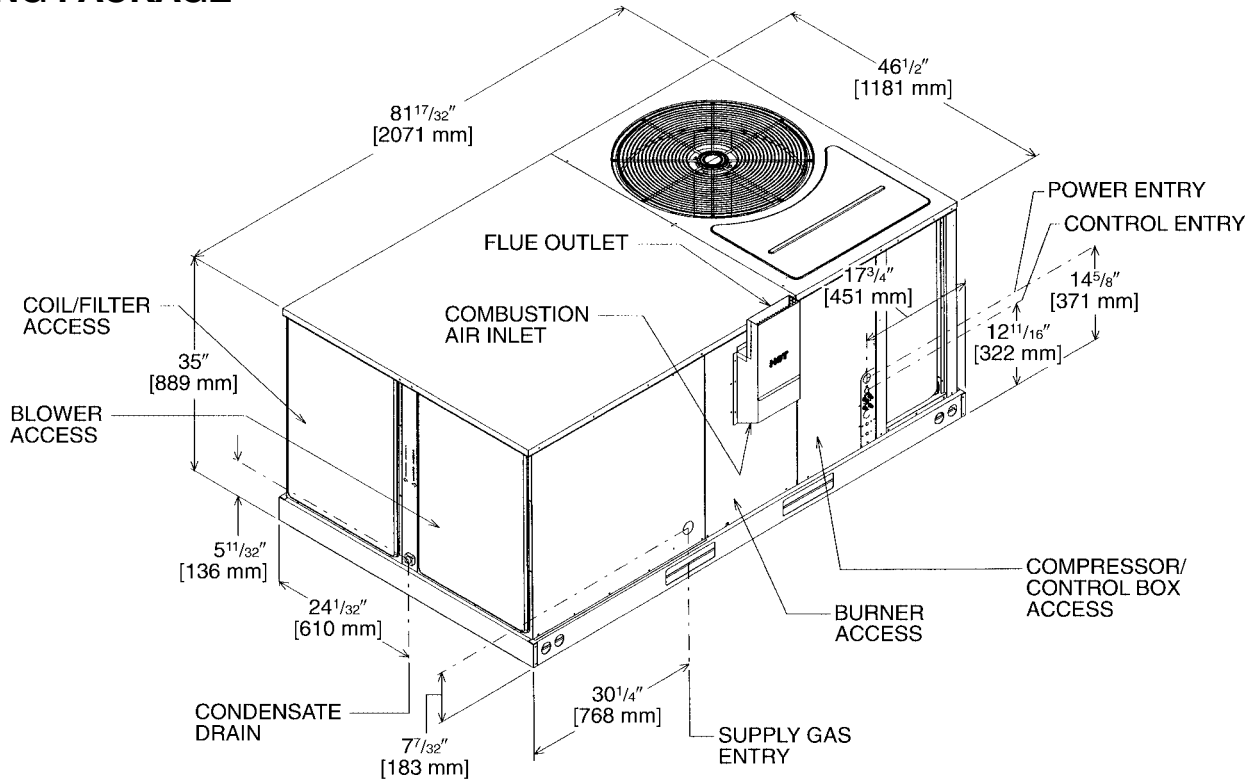

[] Designates Metric Conversions

WEIGHTS

Accessory	3-6 Ton [10.6-21.1 kW]		7.5 Ton [26.4 kW]	
	Shipping	Operating	Operating	Operating
	lbs [kg]	lbs [kg]	lbs [kg]	lbs [kg]
Economizer with Single Enthalpy	70 [32]	60 [27]	80 [36]	70 [32]
Power Exhaust	19 [9]	16 [7]	21 [10]	17 [8]
Fresh Air Damper (Manual)	11 [5]	9 [4]	14 [6]	12 [5]
Fresh Air Damper (Motorized)	13 [6]	11 [5]	16 [7]	14 [6]
Roof Curb 14"	92 [42]	88 [40]	92 [42]	88 [40]
Roof Curb 24"	108 [49]	104 [47]	108 [49]	104 [47]
Concentric Diffuser 18" Flush	37 [17]	26 [12]	37 [17]	26 [12]
Concentric Diffuser 20" Flush	54 [24]	42 [19]	54 [24]	42 [19]
Side Discharge Concentric Diffuser RXRN-FA60	35 [16]	20 [9]	—	—
Side Discharge Concentric Diffuser RXRN-FA65	55 [25]	40 [18]	55 [25]	40 [18]

CENTER OF GRAVITY (C.G.)

Capacity Tons [kW]	A in. [mm]	B in. [mm]
3-6 [10.6-21.1]	38 ¹ / ₄ [972]	25 ³ / ₄ [654]
7.5 [26.4]	39 [991]	26 ¹ / ₈ [664]

Capacity Tons [kW]	Corner Weights by Percentage			
	A	B	C	D
3-6 [10.6-21.1]	22%	27%	23%	28%
7.5 [26.4]	23%	29%	21%	27%

CLEARANCES

(3 to 7.5 Ton [10.6 to 26.4 kW] Models)

The following minimum clearances are recommended for proper unit performance and serviceability.

Recommended Clearance in. [mm]	Location
48 [1219]	A - Front
18 [457]	B - Condenser Coil
12 [305]	C - Duct Side
36 [914]	D - Evaporator End
60 [1524]	E - Above

*Without Economizer. 57" [1448 mm] With Economizer

NOTE: Supply duct may be installed with "0" inch clearance to combustible materials, provided 1" [25.4 mm] minimum Fiberglass insulation is applied either inside or on the outside of the duct.

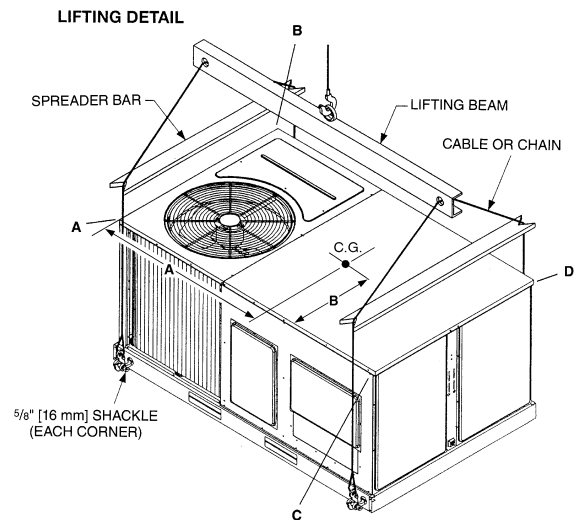
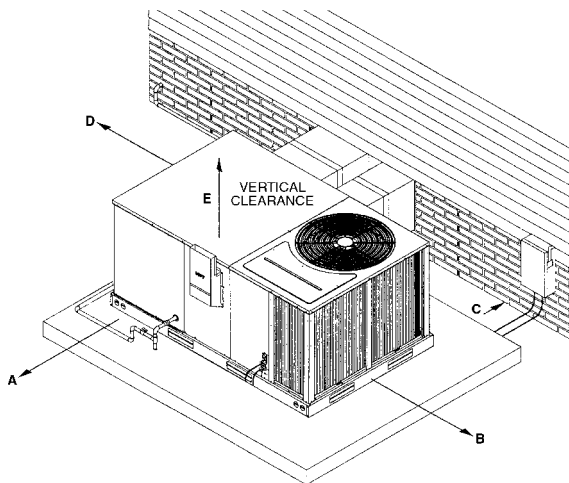

[] Designates Metric Conversions

ACCESSORY EQUIPMENT

Accessory Description	Model Application (RLKA) 3 to 6 Ton [10.6 to 21.1 kW]	Accessory Model No. (RLKA) 3 to 6 Ton [10.6 to 21.1 kW]	Factory Installed (RLKA) 3 to 6 Ton [10.6 to 21.1 kW]	Accessory Model No. (RLMA) 6 [21.1 kW] & (RLKA) 7.5 Ton [26.4 kW]	Factory Installed (RLMA) 6 [21.1 kW] & (RLKA) 7.5 Ton [26.4 kW]
Thermostats	RKKA-/RKMA-	See Thermostat Specification Sheet (T22-001)	No	See Thermostat Specification Sheet (T22-001)	No
Roofcurb 14"	RKKA-/RKMA-	RXKG-CAD14	No	RXKG-CAD14	No
Roofcurb 24"	RKKA-/RKMA-	RXKG-CAD24	No	RXKG-CAD24	No
Roofcurb Adapters	RKKA-/RKMA-	RXR-BCDB21 RXR-BCDB22 RXR-BCDB23	No	RXR-CCCE50	No
Economizer with Single Enthalpy ②	RKKA-/RKMA-	RXRD-MECM3	Yes	RXRD-MCCM3	Yes
Dual Enthalpy Kit	RKKA-/RKMA-	RXR-AV02	No	RXR-AV02	No
CO ₂ Sensor Only	RKKA-/RKMA-	RXR-AR02	No	RXR-AR01	No
Power Exhaust	RKKA-/RKMA-	RXR-BGF04 (C,D,Y)	No	RXR-BGF03 (C,D,Y)	No
Fresh Air Damper Manual	RKKA-/RKMA-	RXR-FBA1	No	RXR-FCA1	No
Fresh Air Damper Motorized	RKKA-/RKMA-	RXR-FBB1	No	RXR-FCB1	No
Rectangular to Round 18" Duct Adapters for Concentric Diffuser	RKKA-/RKMA-	RXMC-CB03	No	N/A	No
Rectangular to Round 20" Duct Adapters for Concentric Diffuser	RKKA-/RKMA-	RXMC-CB04	No	RXMC-CC04	No
Concentric Diffuser 18" Step	RKKA-/RKMA-	RXRN-FA60	No	N/A	No
Concentric Diffuser 18" Flush	RKKA-/RKMA-	RXRN-FA70	No	N/A	No
Concentric Diffuser 20" Step	RKKA-/RKMA-	RXRN-FA65	No	RXRN-FA65	No
Concentric Diffuser 20" Flush	RKKA-/RKMA-	RXRN-FA75	No	RXRN-FA75	No
Rectangular to Round 16" Side	RKKA-/RKMA-	RXMC-BB01	No	N/A	No
Louver Kit (2 Sides)	RKKA-A036/A042	RXR-AAD01A	Yes	N/A	No
Louver Kit (3 Sides)	RKKA-A048/A060/073 All RKMA- Models	RXR-AAD01B	Yes	RXR-AAD01B	Yes
High Pressure Control	RKKA-	RXAB-A02 ③	Yes	RXAB-A05 ③	Yes
Low Pressure Control	RKKA-	RXAC-A02 ③	Yes	RXAC-A05 ③	Yes
Time Delay	RKKA-/RKMA-	RXMD-B01	Yes	RXMD-B04	Yes
Low Ambient Control to 0°F [-18°C]	RKKA-/RKMA-	RXRZ-A18	Yes	RXRZ-A85	Yes
LP Conversion Kits for use with White Rodgers Gas Valve ①	RKKA-/RKMA-	RXGJ-EP84W	No	RXGJ-EP84W	No
LP Conversion Kits for use with Honeywell Gas Valve ①	RKKA-/RKMA-	RXGJ-EP85H	No	RXGJ-EP85H	No
LP Conversion Kits for use with Two-Stage Gas Valve ①	RKKA-A085**13T	RXGJ-EP86W	No	RXGJ-EP86W	No
Canadian High Altitude Kit (for Natural Gas Only) ①	RKKA-/RKMA-	RXR-AH01	No	RXR-AH01	No

*Voltage J = 208/230 VAC-1PH-60HZ D = 460 VAC-3PH-60HZ
C = 208/230 VAC-3PH-60HZ Y = 575 VAC-3PH-60HZ

NOTES: ① If a particular unit is to be converted to operate on **LP (propane)** for elevations above 2000 ft. in Canada, the existing Natural Gas to LP Conversion Kits for the subject models already contain the necessary orifices and instructions to de-rate the input for 2000-4500 ft. Canadian applications.

② Economizer is designed for downflow or horizontal applications.
③ Standard on RKKA-A073 and All RKMA- Models.

[] Designates Metric Conversions

THERMOSTATS



300-Series *
Deluxe Programmable

200-Series *
Programmable

100-Series *
Non-Programmable

400-Series *
Special Applications/Programmable

Brand	Unique Model Number Prefix	Descriptor (3 Characters)	Series (3 Characters)	System (2 Characters)	Type (2 Characters)
UHC	-	TST	101	GE	MS
UHC=Ruud		TST=Thermostat	100=Non-Programmable	GE=Gas/Oil/Electric	SS=Single-Stage
			200=Programmable	HP=Heat Pump	MS=Multi-Stage
			300=Deluxe Programmable	MD=Modulating Furnace	
			400=Special Applications/Programmable	DF=Dual Fuel	
				UN=Universal AC/HP/GE	

* Photos are representative. Actual models may vary.

For detailed thermostat match-up information, see specification sheet form number T22-001.

Roofcurb Adapters

Old Models

MEDIUM CABINET (3 TON [11 kW])

(-)SNC, (-)SND, (-)SNE
(-)RGE, (-)RGF, (-)RGG
(-)PNC, (-)PND

LARGE CABINET

(3-3 1/2 TON [11-12 kW])
(-)RGE, (-)RGF, (-)RGG,
(-)RGH (3 TON [11 kW])

EXTRA LARGE CABINET

(3 1/2-5 TON [12-18 kW])
(-)SNC, (-)SND, (-)SNE
(-)RGE, (-)RGF,
(-)RGG (4-5 TON [14-18 kW])
(-)PNC, (-)PND, (-)RGH
(3 1/2, 4 TON [12-14 kW])

COMMERCIAL PACKAGE UNIT

(6.5 & 7.5 TON [23-26 kW])
(-)RCF, (-)REF, (-)RGF131 & 201, RGF150

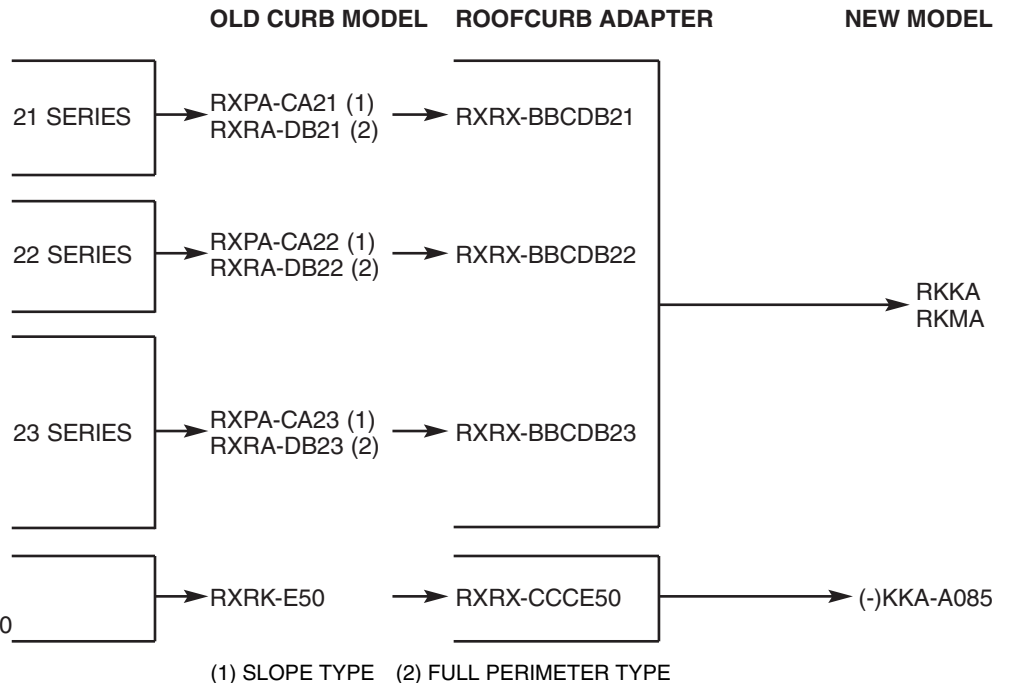

(1) SLOPE TYPE (2) FULL PERIMETER TYPE

[] Designates Metric Conversions

ROOFCURBS (Full Perimeter)

- Ruud's new roofcurb design can be utilized on 3 through 7.5 ton [10.6-26.4 kW] models.
- Two available heights (14" [356 mm] and 24" [610 mm]) for ALL models.
- Quick assembly corners for simple and fast assembly.
- Opening provided in bottom pan to match the "Thru the Curb" electrical connection opening provided on the unit base pan.
- 2" [51 mm] x 4" [102 mm] Nailer provided.
- Insulating panels provided.
- Sealing gasket (28" [711 mm]) provided with Roofcurb.
- Packaged for easy field assembly.

Roofcurb Model	Height of Curb
RXKG-CAD14	14" [356 mm]
RXKG-CAD24	24" [610 mm]

TYPICAL INSTALLATION

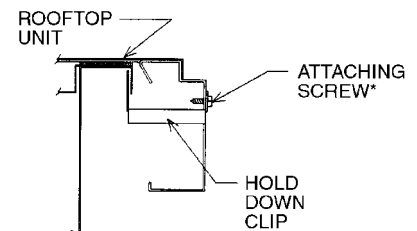
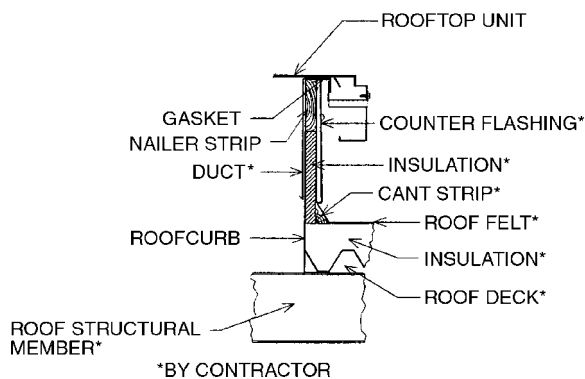
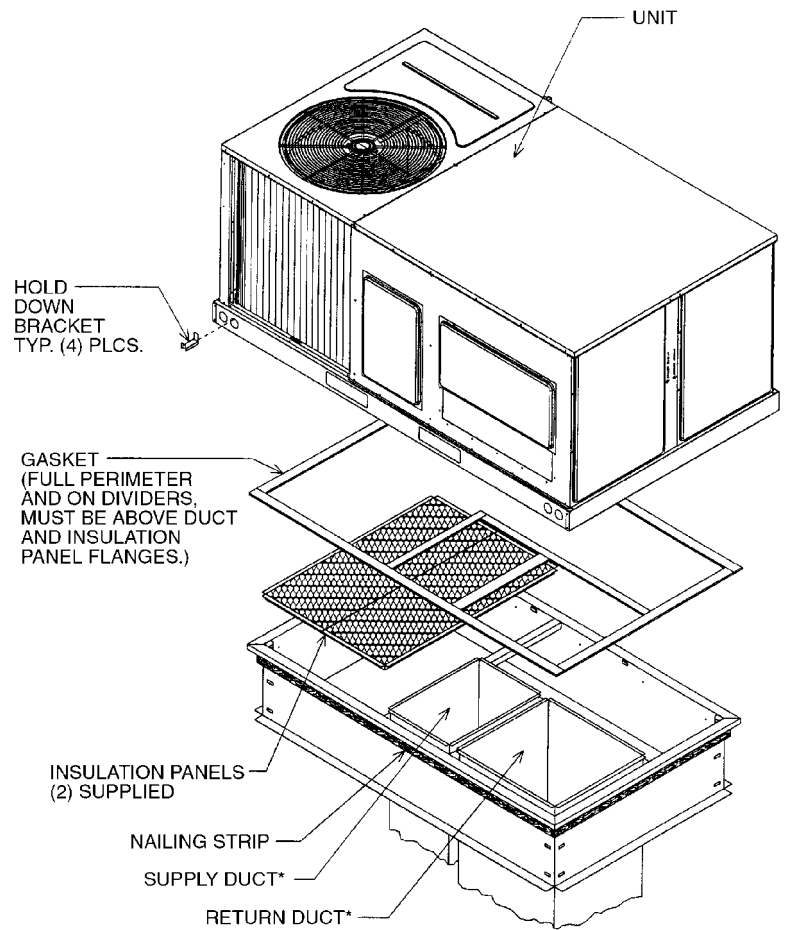

[] Designates Metric Conversions

ROOFCURBS (Cont.)

**ROOFCURB FOR
RKMA 6 TON [21.1 kW] MODELS
RKKA 3-7.5 TON [10.6-26.4 kW] MODELS**

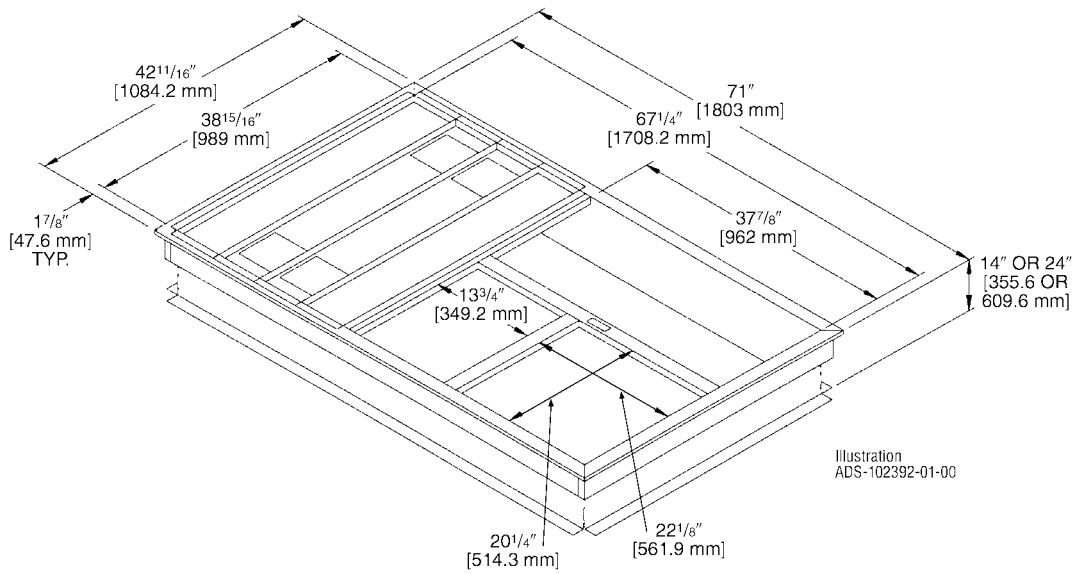

Illustration
ADS-102392-01-00

[] Designates Metric Conversions

ECONOMIZERS

RXRD-MECM3—RKKA 3-6 Ton [10.6-21.1 kW] Models
RXRD-MCCM3—RKMA 6 Ton [21.1 kW] Models
RKKA 7.5 Ton [26.4 kW] Models

RXRX-AV02—3-7.5 Ton [10.6-26.4 kW] Models

RXRX-AR02—3-7.5 Ton [10.6-26.4 kW] Models

- Features **Honeywell** Analog Controls
- Available factory installed or field accessory
- Gear Driven Direct Drive Actuator
- Fully Modulating (0-100%)
- Low Leakage Dampers
- Horizontal or Downflow Applications
- Slip-In Design for Easy Installations
- Plug-In Polarized 9-pin Electrical Connections
- Pre-configuring—No Field Adjustments Necessary
- Standard Barometric Relief Damper Provided
- Single Enthalpy with Dual Enthalpy upgrade kit
- CO₂ Input Sensor Available (field installed)
- Economizer slips in complete for downflow or horizontal duct applications
- Field assembled hood ships with Economizer
- Optional Remote minimum position (Honeywell #S963B1128) is available from ProStock.
- Field installed power exhaust available.

[] Designates Metric Conversions

Single Enthalpy (with Barometric Relief)

Dual Enthalpy Kit

Optional CO₂ Sensor

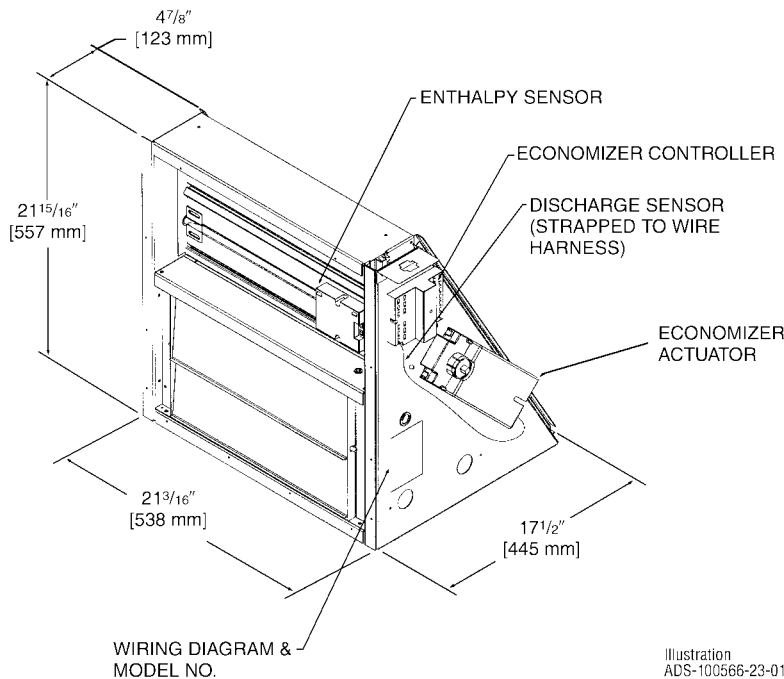
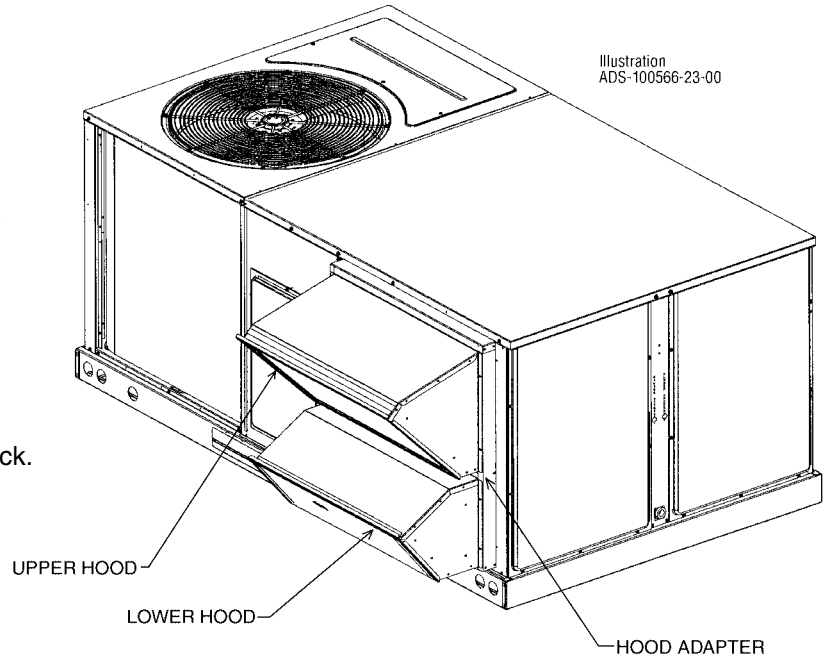

INTEGRAL POWER EXHAUST FOR ECONOMIZER (FIELD INSTALLED ONLY)

- RXRX-BGF04C—RKKA 3-6 Ton [10.6-21.1 kW]
Models 208-230 V, 1 PH, 60 Hz
- RXRX-BGF04D—RKKA 3-6 Ton [10.6-21.1 kW]
Models 460 V, 3 PH, 60 Hz
- RXRX-BGF04Y—RKKA 3-6 Ton [10.6-21.1 kW]
Models 575 V, 3 PH, 60 Hz
- RXRX-BGF03C—RKMA 6 Ton [21.1 kW]
RKKA 7.5 Ton [26.4 kW]
Models 208-230 V, 1 PH, 60 Hz
- RXRX-BGF03D—RKMA 6 Ton [21.1 kW]
RKKA 7.5 Ton [26.4 kW]
Models 460 V, 3 PH, 60 Hz
- RXRX-BGF03Y—RKMA 6 Ton [21.1 kW]
RKKA 7.5 Ton [26.4 kW]
Models 575 V, 3 PH, 60 Hz

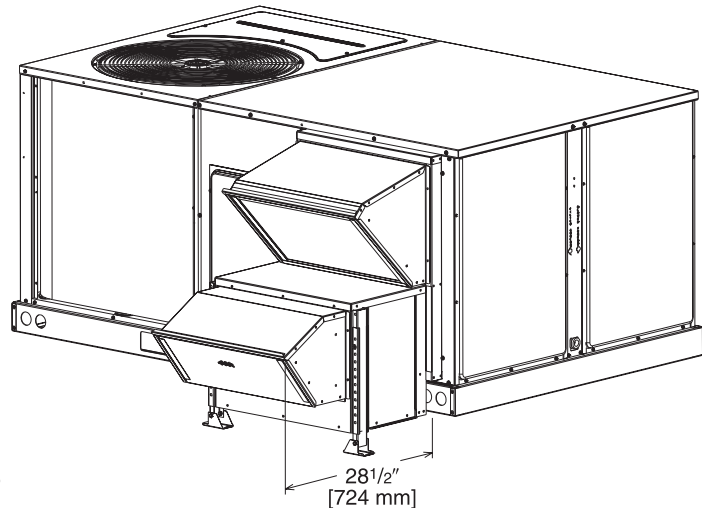

- For Honeywell economizer.
- Downflow or horizontal applications.
- Requires separate 208-230 volt – 1 PH power supply with disconnect or requires separate 460V - 3 PH power supply with disconnect.
- Adjustable switch on economizer, factory preset to energize power exhaust at 95% outside air position.
- Polarized plug connects power exhaust relay to economizer.

POWER EXHAUST KIT FOR RXRD-MCCM(-), RXRD-MECM(-) ECONOMIZERS

Model No.	No. of Fans	Volts	Phase	Watts (ea.)	High Speed		FLA (ea.)	LRA (ea.)
					CFM ①	RPM		
RXRX-BGF03C	1	208/230	1	1000	2500	1725	4.4	23.7
RXRX-BGF03D	1	460	1	800	2370	1620	1.8	4.1
RXRX-BGF03Y ②	1	575	1	800	2370	1620	1.5	3.3
RXRX-BGF04C	1	208/230	1	1000	2500	1725	4.4	23.7
RXRX-BGF04D	1	460	1	800	2370	1620	1.8	4.1
RXRX-BGF04Y ②	1	575	1	800	2370	1620	1.5	3.3

① CFM is at 0" W.C. external static pressure.

② Unit includes 575 to 460 Volt step-down transformer.

FRESH AIR DAMPER

RKKA 3-6 Ton [10.6-21.1 kW] Models
RXRF-FBA1 (Manual)
RXRF-FBB1 (Motorized)

RKMA 6 Ton [21.1 kW] Models
RKKA 7.5 Ton [26.4 kW] Models
RXRF-FCA1 (Manual)
RXRF-FCB1 (Motorized)

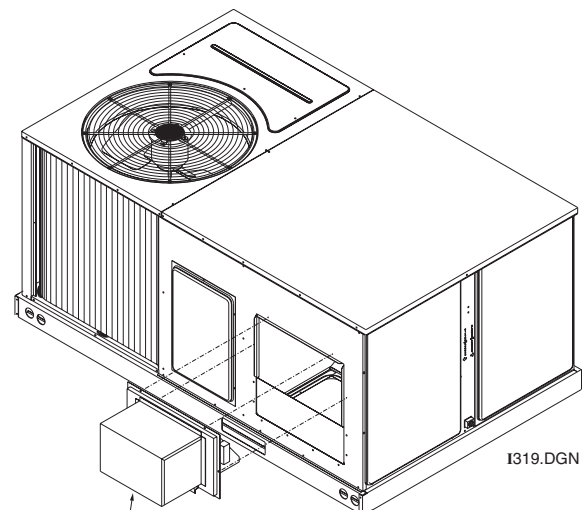

FRESH AIR DAMPER

[] Designates Metric Conversions

DUCT ADAPTERS (RKKA 3-6 Ton [10.6-21.1 kW] Models) Rectangular to Round Transitions (Downflow)

Two sizes available
(18" [457 mm] and
20" [508 mm] round)
fit all units. Drops
into and secures to
RXKG- Series Roofcurbs.
**For use with
Concentric Diffusers.**

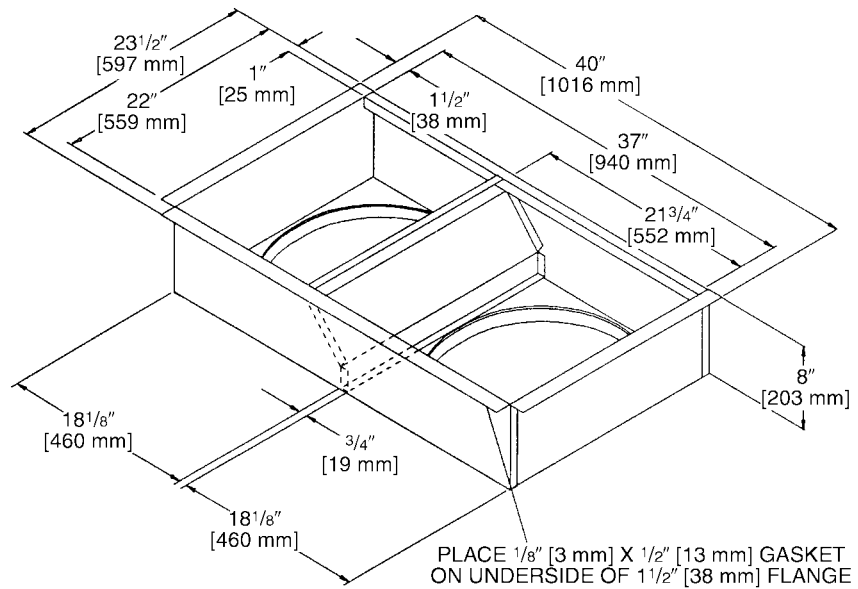

DUCT ADAPTERS (RKMA 6 Ton [21.1 kW] Models) (RKKA 7.5 Ton [26.4 kW] Models) Rectangular to Round Transitions (Downflow)

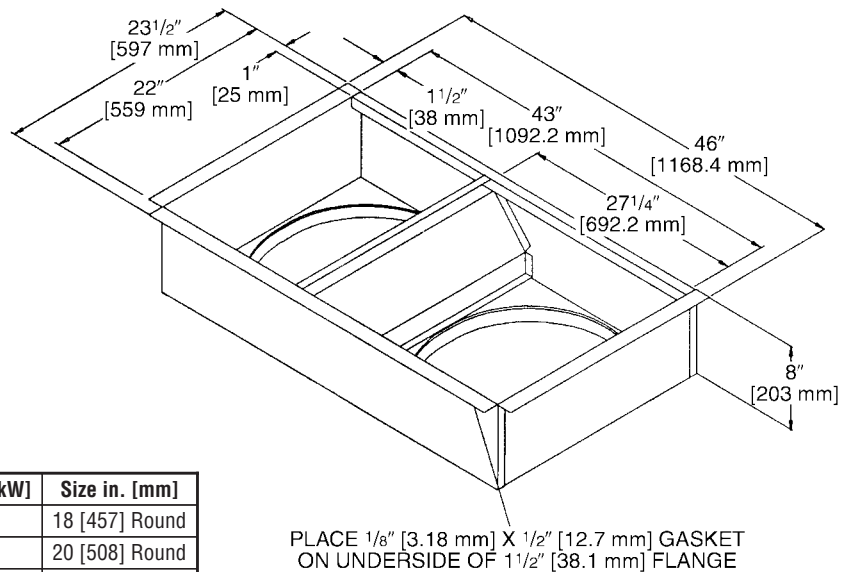

Accessory Model No.	Model Application Tons [kW]	Size in. [mm]
RXMC-CB03	3-6 [10.6-21.1]	18 [457] Round
RXMC-CB04	3-6 [10.6-21.1]	20 [508] Round
RXMC-CC04	7.5 [26.4]	20 [508] Round

[] Designates Metric Conversions

SIDE DISCHARGE CONCENTRIC DIFFUSER

RXRN-FA60 (3 to 6 Ton [10.6 to 21.1 kW] Models)
 RXRN-FA65 (3 to 7.5 Ton [10.6 to 26.4 kW] Models)

For Use With Duct Adapter (RXMC)

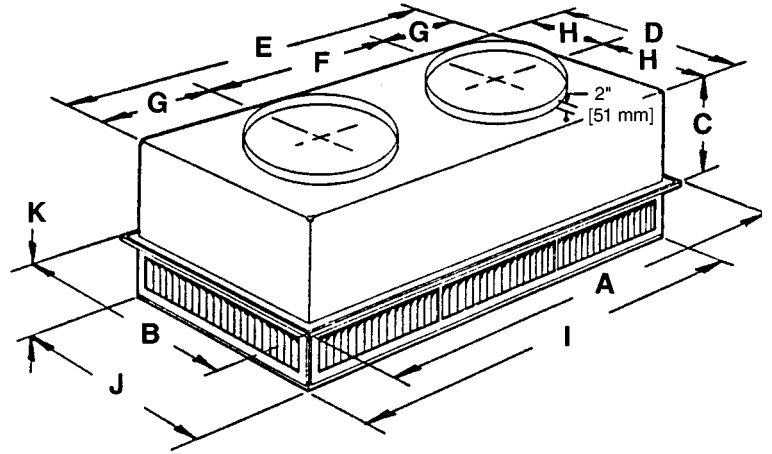

DIMENSIONAL DATA

Model No.	A	B	C	D	E	F	G	H	I	J	K	Duct Size
RXRN-FA60	47 ⁵ / ₈ " [1210 mm]	23 ⁵ / ₈ " [600 mm]	11 ³ / ₈ " [289 mm]	21 ¹ / ₂ " [546 mm]	45 ¹ / ₂ " [1156 mm]	22 ¹ / ₂ " [572 mm]	11 ¹ / ₂ " [292 mm]	10 ³ / ₄ " [273 mm]	45 ¹ / ₂ " [1156 mm]	21 ¹ / ₂ " [546 mm]	7 ¹ / ₈ " [181 mm]	18RD
RXRN-FA65	47 ⁵ / ₈ " [1210 mm]	29 ⁵ / ₈ " [752 mm]	14 ³ / ₈ " [365 mm]	27 ¹ / ₂ " [699 mm]	45 ¹ / ₂ " [1156 mm]	22 ¹ / ₂ " [572 mm]	11 ¹ / ₂ " [292 mm]	13 ³ / ₄ " [349 mm]	45 ¹ / ₂ " [1156 mm]	27 ¹ / ₂ " [699 mm]	8 ¹ / ₈ " [206 mm]	20RD

ENGINEERING DATA

Model No.	CFM [L/s]	Static Pressure	Throw Feet	Neck Vel.	Jet Vel.	Noise Level
RXRN-FA60	1000 [472]	.14	10-17	351	351	20
	1200 [566]	.17	11-18	421	421	20
	1400 [661]	.20	12-19	491	491	20
	1600 [755]	.24	12-20	561	561	20
	1800 [850]	.30	13-21	632	632	20
	2000 [944]	.36	14-23	702	702	20
RXRN-FA65	2200 [1038]	.40	16-25	772	772	20
	2600 [1227]	.17	24-29	669	669	20
	2800 [1321]	.20	25-30	720	720	25
	3000 [1416]	.25	27-33	772	772	25
	3200 [1510]	.31	28-35	823	823	25
3400 [1605]	.37	30-37	874	874	30	

[] Designates Metric Conversions

FLUSH MOUNT CONCENTRIC DIFFUSER

RXRN-FA70 (3 to 6 Ton [10.6 to 21.1 kW] Models)
 RXRN-FA75 (3 to 7.5 Ton [10.6 to 26.4 kW] Models)

For Use With Duct Adapter (RXMC)

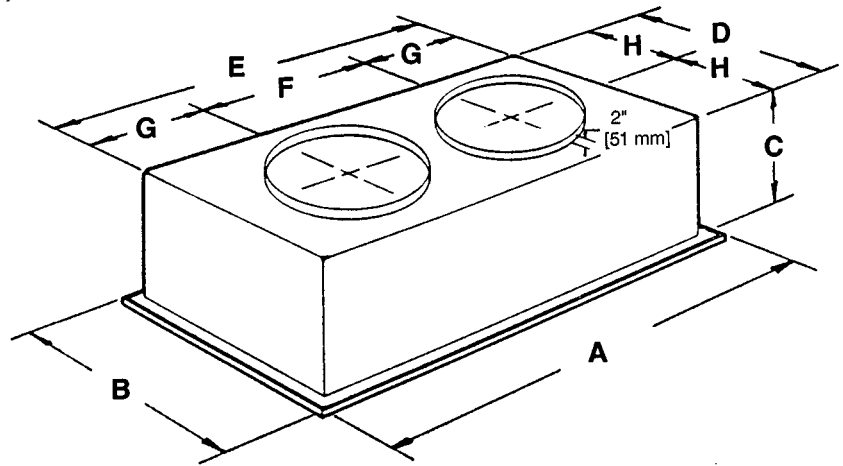

DIMENSIONAL DATA

Model No.	A	B	C	D	E	F	G	H	Duct Size
RXRN-FA70	47 ⁵ / ₈ " [1210 mm]	23 ⁵ / ₈ " [600 mm]	13 ¹ / ₂ " [343 mm]	21" [533 mm]	45" [1143 mm]	22 ¹ / ₂ " [572 mm]	11 ¹ / ₄ " [286 mm]	10 ¹ / ₂ " [267 mm]	18RD
RXRN-FA75	47 ⁵ / ₈ " [1210 mm]	29 ⁵ / ₈ " [752 mm]	16 ⁵ / ₈ " [422 mm]	27" [686 mm]	45" [1143 mm]	22 ¹ / ₂ " [572 mm]	11 ¹ / ₄ " [286 mm]	13 ¹ / ₂ " [343 mm]	20RD

ENGINEERING DATA

Model No.	CFM [L/s]	Static Pressure	Throw Feet	Neck Vel.	Jet Vel.	Noise Level
RXRN-FA70	1000 [472]	.14	15-20	391	694	20
	1200 [566]	.17	16-22	469	833	25
	1400 [661]	.20	17-24	547	972	30
	1600 [755]	.24	18-25	625	1111	30
	1800 [850]	.30	20-28	703	1250	35
	2000 [944]	.36	21-29	781	1389	40
	2200 [1038]	.40	22-30	859	1528	40
RXRN-FA75	2600 [1227]	.17	19-24	663	1294	30
	2800 [1321]	.20	20-28	714	1393	35
	3000 [1416]	.25	21-29	765	1492	35
	3200 [1510]	.31	22-29	816	1592	40
	3400 [1605]	.37	22-30	867	1692	40

[] Designates Metric Conversions

SAMPLE SPECIFICATIONS

Unit shall be completely factory assembled and performance tested to provide the required cooling and heating functions suitable for outdoor installations. Unit shall be UL/cUL listed and rated in accordance to ARI Standard 210.

CABINET

Unit casing, base pan and framework shall be manufactured of galvanized sheet metal primed and finished with powder paint capable of withstanding a 1000-hour salt spray test per ASTM B 117. Unit interior cabinet surfaces shall be insulated with a minimum 1/2-inch thick foil faced insulation. Access panels shall be easily removable providing access to the blower, filter, heating compartment, and compressor/control box. Unit base rails shall be provided with fork insertion slots and rigging holes. Condensate drain pan shall be of sloped design to conform to ASHRAE 62. Unit shall be supplied ready for vertical airflow and be easily convertible to horizontal airflow at or before installation.

COMPRESSOR(S)

Unit shall be provided with fully hermetic scroll compressor(s) with internally protected safety controls. Two compressors shall be utilized on 6 ton [21.1 kW] models.

COILS

The evaporator and condenser coils shall be fabricated of copper tubes with mechanically bonded aluminum plate fins. They shall be pressure tested prior to assembly into the unit, and electronically leak tested after assembly.

CONDENSER FAN

A single direct drive propeller fan shall discharge air vertically upward. The fan motor shall be permanently lubricated and have built-in overload protection.

EVAPORATOR BLOWER

A single, double inlet, centrifugal wheel shall rotate in permanently lubricated ball bearings. The wheel shall be made from steel with corrosion resistant finish and shall be statically and dynamically balanced.

HEATING SECTION

Heat exchanger shall be of the tubular type made of aluminized steel. Burners shall be of the in-shot type. Unit shall be equipped with an integrated direct spark ignition control board with built-in diagnostics feature. Safeties to include limit, lockout, and flame roll-out switches.

ACCESSORIES

ROOF CURB

Curb shall be full perimeter type, complying with the standards of the National Roofing Contractors Association. Design shall provide for drop-in of supply and return ducts prior to setting unit, and include an insulating panel for the rest of the curb area.

ECONOMIZER

Economizer shall be completely assembled for field installation. Unit shall include all controls and dampers including the barometric relief damper. Shall be offered for both vertical and horizontal applications.

MANUAL FRESH AIR DAMPER

Damper shall consist of damper and rainhood which is manually preset to admit up to 35% of outside air for field installation.

MOTORIZED FRESH AIR DAMPER

Damper shall consist of motor, damper, and rainhood which can admit up to 35% of outside air for field installation.

PRESSURE CONTROLS

High and low pressure controls shall be included for field or factory installation.

LOW AMBIENT CONTROL

Low ambient control shall be provided to cycle the condenser fan in response to condensing pressure and allow operation to 0 degrees F. The option shall be field or factory installed.

TIME DELAY CONTROL

Time delay control shall be provided to prevent the compressor from restarting 5 minutes after shutdown. The control shall be field or factory installed.

LOUVER PANEL KITS

Field or factory installed louver kits shall be provided for condenser coil protection against hail or flying debris.

[] Designates Metric Conversions

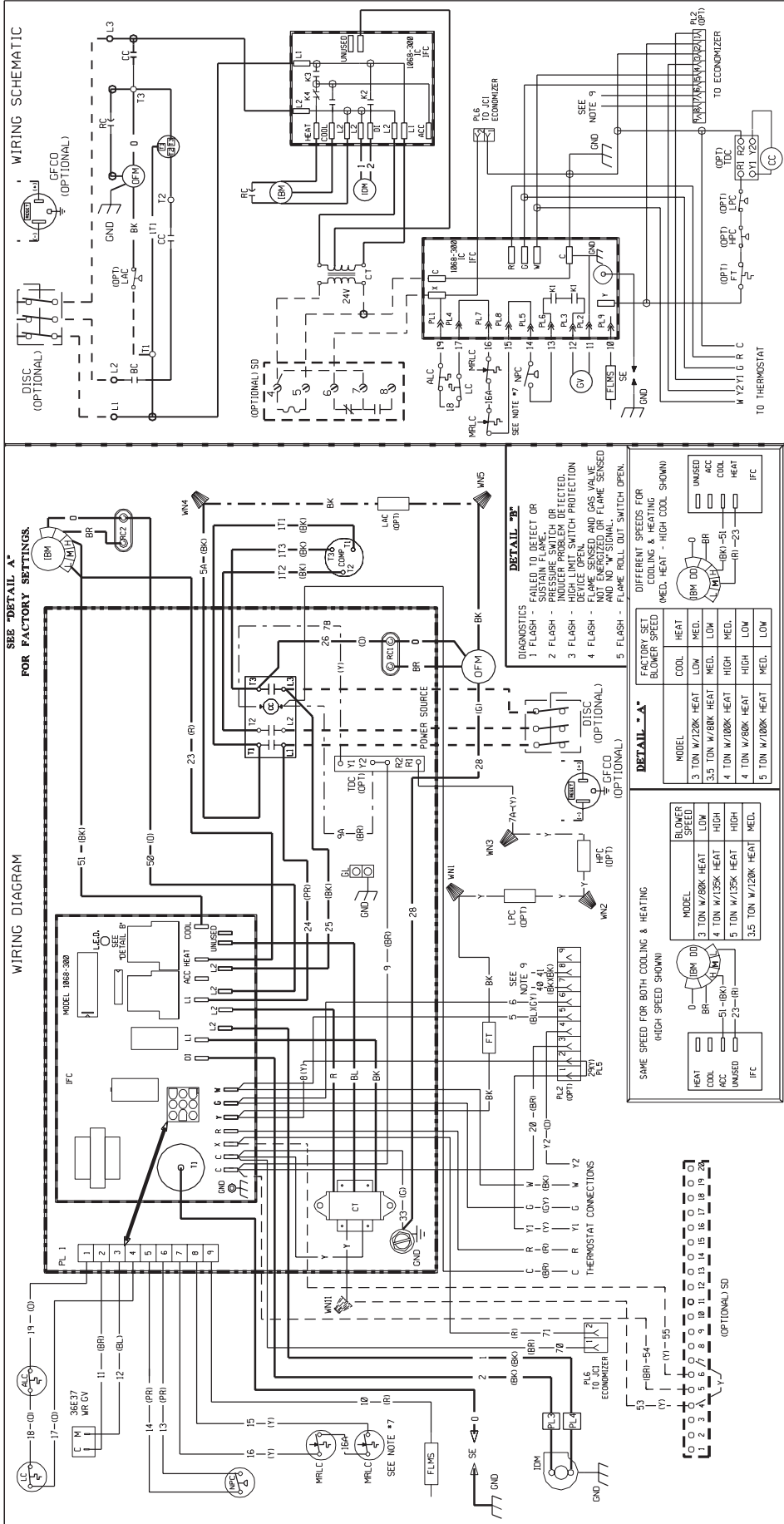

WIRE COLOR CODE

BK	BLACK
BR	BROWN
BL	BLUE
G	GREEN
GY	GRAY
O	ORANGE
PR	PURPLE
R	RED
W	WHITE
Y	YELLOW

ELECTRICAL WIRING DIAGRAM

208 / 230, 3 PHASE
DIRECT DRIVE

REV 08

DWG. NO. 90-23596-09

DATE 5-25-98

DR. BY RG

APP. BY

WIRING INFORMATION

LINE VOLTAGE

- FACTORY STANDARD
- FACTORY OPTION
- FIELD INSTALLED

LOW VOLTAGE

- FACTORY STANDARD
- FACTORY OPTION
- FIELD INSTALLED

REPLACEMENT WIRE

- MUST BE THE SAME SIZE AND TYPE OF INSULATION AS ORIGINAL (105 C° MIN.)

WARNING

- CABINET MUST BE PERMANENTLY GROUNDED AND CONFORM TO I.E.C., N.E.C., AND LOCAL CODES AS APPLICABLE.

NOTES:

- CONNECTORS SUITABLE FOR USE WITH COPPER CONDUCTORS ONLY.
- COMPRESSOR MOTOR THERMALLY PROTECTED. ALL 3 PHASE MODELS ARE PROTECTED UNDER PRIMARY SINGLE PHASE CONDITIONS.
- CONTROL TRANSFORMER PRIMARY LEADS RED-COMMON, BLUE-208V, BLACK-230V. TRANSFORMER FACTORY WIRED FOR 230 VOLTS. INTERCHANGE BLACK FOR BLUE LEADS FOR 208V OPERATION.
- CONTACTOR FACTORY WIRED. CONNECT FIELD WIRE TO FACTORY SUPPLIED CONTACTOR IN ELECTRICAL BOX.
- LOW VOLTAGE CIRCUIT IS NECC-CLASS 2 WITH A CLASS 2 TRANSFORMER, 24V/50/60 HZ SUPPLIED.
- CONNECT FIELD WIRING IN GROUNDED RAIN TIGHT CONDUIT TO 60 HZ FUSED DISCONNECT.
- ONLY ONE MRLC IS NEEDED ON THE 00.0000 INPUT UNIT.
- MOTOR FACTORY WIRED FOR CORRECT SPEED.
- WIRES FROM PL2 (7 & 8) GO TO THE MIXED AIR SENSOR ON THE OPTIONAL ECONOMIZER.
- 10, 12 IS USED ONLY FOR THE OPTIONAL ECONOMIZER.

COMPONENT CODE

AUX. LIMIT CONTROL	MRLC	MANUAL RESET LIMIT CONTROL
COMPRESSOR	CC	NEGATIVE PRESSURE CONTROL
CONTROL TRANSFORMER	CT	OUTDOOR FAN MOTOR
DISC	DISCONNECT SWITCH	FLUO CAPACITOR
FLMS	FLAME SENSOR	SMOKE DETECTOR
GFCD	GROUND FAULT	SPARK ELECTRODE
CONVENIENCE OUTLET	CL	TIME DELAY CONTROL
GROUND LUG	GL	WIRE NUT
GAS VALVE	GV	
HIGH PRESSURE CONTROL	HPC	
INDOOR BLOWER MOTOR DIRECT DRIVE	IBM	
INDUCED DRAFT MOTOR	IDM	
INTEGRATED FURNACE CONTROL	IFC	
LOW AMBIENT COOLING CONTROL	LAC	
LIMIT CONTROL	LC	
LOW PRESSURE CONTROL	LPC	

DWG. NO. 90-23596-09

REV 08

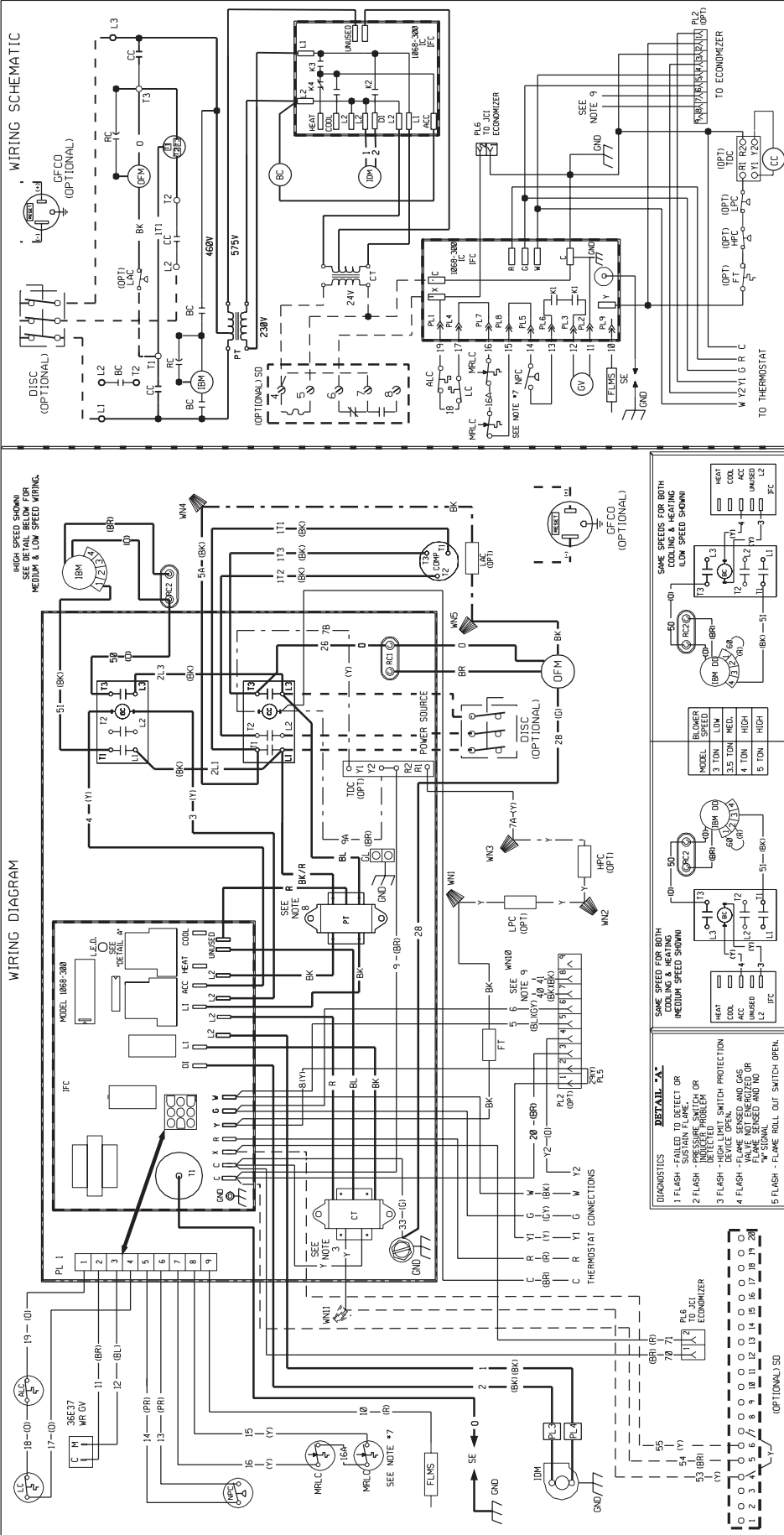

WIRING SCHEMATIC

WIRING DIAGRAM

COMPONENT CODE

ALC	AUX. LIMIT CONTROL
BC	BLOWER CONTACTOR
CC	COMPRESSOR CONTACTOR
CDMP	COMPRESSOR
CT	CONTROL TRANSFORMER
DISC	DISCONNECT SWITCH
FLMS	FLAME SENSOR
FT	FREEZE STAT
GFCO	GROUND FAULT CONVENIENCE OUTLET
GL	GROUND LUG
GR	GROUND
HPC	HIGH PRESSURE CONTROL
IDM	INDUCED DRAFT MOTOR
IFC	INTERGRATED FURNACE CONTROL
LAC	LOW AMBIENT COOLING CONTROL
LC	LIMIT CONTROL

WIRE COLOR CODE

BK	BLACK	GY	GRAY	R	RED
BR	BROWN	O	ORANGE	W	WHITE
BL	BLUE	PK	PINK	Y	YELLOW
G	GREEN	PR	PURPLE		

WIRING INFORMATION

LINE VOLTAGE
 -FACTORY STANDARD
 -FACTORY OPTION
 -FIELD INSTALLED

LOW VOLTAGE
 -FACTORY STANDARD
 -FACTORY OPTION
 -FIELD INSTALLED

REPLACEMENT WIRE
 -MUST BE THE SAME SIZE AND TYPE OF INSULATION AS ORIGINAL (105 C MIN.)
 -CABINET MUST BE PERMANENTLY GROUNDED AND CONFORM TO I.E.C., N.E.C., C.E.C. AND LOCAL CODES AS APPLICABLE.

NOTES:

- CONNECTORS SUITABLE FOR USE WITH COPPER CONDUCTORS ONLY.
- COMPRESSOR MOTOR THERMALLY PROTECTED ALL 3 PHASE MODELS ARE PROTECTED UNDER PRIMARY SINGLE PHASE CONDITIONS.
- CONTROL TRANSFORMER PRIMARY LEADS RED-COMMON BLUE-208V. BLACK-240V. TRANSFORMER FACTORY WIRED FOR 230 VOLTS. INTERCHANGE BLACK FOR BLUE LEADS FOR 208V OPERATION.
- CONTACTOR FACTORY WIRED. CONNECT FIELD WIRE TO FACTORY SUPPLIED CONTACTOR IN ELECTRICAL BOX.
- LOW VOLTAGE CIRCUIT IS N.E.C. CLASS 2 WITH A CLASS 2 TRANSFORMER 24V/50V/60 HZ SUPPLIED.
- CONNECT FIELD WIRING IN GROUNDED RAIN TIGHT CONDUIT TO 60 HZ ONLY ONE DISCONNECT.
- ONLY ONE MRLC IS NEEDED ON THE 98,000 INPUT UNIT.
- POWER TRANSFORMER PRIMARY LEADS BLUE-COMMON BK/RED-480V. 60 HZ / 300V 60 HZ. RED-575V 60 HZ / 115V 50 HZ.
- WIRES FROM PL 2 17 81 GO TO THE MIXED AIR SENSOR ON THE OPTIONAL ECONOMIZER.
- 10, Y2 IS USED ONLY FOR THE OPTIONAL ECONOMIZER.

DIAGNOSTICS

- FLASH - FAILED TO DETECT OR SUSTAIN FLAME.
- FLASH - PRESSURE SWITCH OR DEFERRED
- FLASH - DEVICE OPEN SWITCH PROTECTION
- FLASH - FLAME SENSED AND GAS FLAME SENSED AND NO "W" SIGNAL
- FLASH - FLAME ROLL OUT SWITCH OPEN.

DETAILS

1. SAME SPEED FOR BOTH COOLING & HEATING (MEDIUM SPEED SHOWN)

2. SAME SPEEDS FOR BOTH COOLING & HEATING (LOW SPEED SHOWN)

DR. BY

JHB

APP. BY

JHB

DATE

7-7-98

DWG. NO.

90-23596-12

REV

02

BEFORE PURCHASING THIS APPLIANCE, READ IMPORTANT ENERGY COST AND EFFICIENCY INFORMATION AVAILABLE FROM YOUR RETAILER.

GENERAL TERMS OF LIMITED WARRANTY*

Ruud will furnish a replacement for any part of this product which fails in normal use and service within the applicable periods stated, in accordance with the terms of the limited warranty.

Heat Exchanger
Factory StandardTen (10) Years

Stainless Steel/1-Phase & 3-Phase Models/
Commercial ApplicationTwenty (20) Years
Stainless Steel/1-Phase Models/
Residential ApplicationLimited Lifetime
CompressorFive (5) Years

***For Complete Details of the Limited Warranty, Including Applicable Terms and Conditions, See Your Local Installer or Contact the Manufacturer for a Copy.**

Before proceeding with installation, refer to installation instructions packaged with each model, as well as complying with all Federal, State, Provincial, and Local codes, regulations, and practices.

**Ruud Heating,
Cooling and
Water Heating**

P.O. Box 17010, Fort Smith, AR 72917



"In keeping with its policy of continuous progress and product improvement, Ruud reserves the right to make changes without notice."