

INSTALLATION INSTRUCTIONS

FOR UPFLOW & DOWNFLOW/HORIZONTAL HIGH EFFICIENCY CONDENSING GAS FURNACES

(-)GRA/(-)GRJ AND (-)GTA/(-)GTJ SERIES



RECOGNIZE THIS SYMBOL AS AN INDICATION OF IMPORTANT SAFETY INFORMATION!

▲ WARNING

IF THE INFORMATION IN THESE INSTRUCTIONS IS NOT FOLLOWED EXACTLY, A FIRE OR EXPLOSION MAY RESULT, CAUSING PROPERTY DAMAGE, PERSONAL INJURY OR DEATH.

▲ WARNING

THESE INSTRUCTIONS ARE INTENDED AS AN AID TO QUALIFIED SERVICE PERSONNEL FOR PROPER INSTALLATION, ADJUSTMENT AND OPERATION OF THIS UNIT. READ THESE INSTRUCTIONS THOROUGHLY BEFORE ATTEMPTING INSTALLATION OR OPERATION. FAILURE TO FOLLOW THESE INSTRUCTIONS MAY RESULT IN IMPROPER INSTALLATION, ADJUSTMENT, SERVICE OR MAINTENANCE, POSSIBLY RESULTING IN FIRE, ELECTRICAL SHOCK, CARBON MONOXIDE POISONING, EXPLOSION, PROPERTY DAMAGE, PERSONAL INJURY OR DEATH.

▲ WARNING

PROPOSITION 65 WARNING: THIS PRODUCT CONTAINS CHEMICALS KNOWN TO THE STATE OF CALIFORNIA TO CAUSE CANCER, BIRTH DEFECTS OR OTHER REPRODUCTIVE HARM.

▲ WARNING

- Do not store or use gasoline or other flammable vapors and liquids, or other combustible materials in the vicinity of this or any other appliance.
- WHAT TO DO IF YOU SMELL GAS
 - Do not try to light any appliance.
 - Do not touch any electrical switch; do not use any phone in your building.
 - Immediately call your gas supplier from a neighbor's phone. Follow the gas supplier's instructions.
 - If you cannot reach your gas supplier, call the fire department.
 - Do not return to your home until authorized by the gas supplier or fire department.
- DO NOT RELY ON SMELL ALONE TO DETECT LEAKS. DUE TO VARIOUS FACTORS, YOU MAY NOT BE ABLE TO SMELL FUEL GASES.
 - U.L. recognized fuel gas and CO detectors are recommended in all applications, and their installation should be in accordance with the manufacturer's recommendations and/or local laws, rules, regulations, or customs.
- Improper installation, adjustment, alteration, service or maintenance can cause injury, property damage or death. Refer to this manual. Installation and service must be performed by a qualified installer, service agency or the gas supplier. In the commonwealth of Massachusetts, installation must be performed by a licensed plumber or gas fitter for appropriate fuel.



Accredited by the RvA



ISO 9002

Certificate Number: 30164

DO NOT DESTROY THIS MANUAL. PLEASE READ CAREFULLY AND KEEP IN A SAFE PLACE FOR FUTURE REFERENCE BY A SERVICEMAN.

INSTALLATION CHECK LIST

REFER TO INSTALLATION INSTRUCTIONS

GAS SUPPLY

- _____ Adequate pipe size
- _____ Correct supply pressure (during furnace operation)
- _____ Manifold pressure
- _____ No gas leaks
- _____ L.P. Kit Number (if applicable)

ELECTRICAL

- _____ 115 V.A.C. supply (Single Circuit)
- _____ Polarity observed
- _____ Furnace properly grounded
- _____ Adequate wire size

FURNACE INSTALLATION

- _____ Adequate clearance to combustibles
- _____ Adequate clearance for service (at front)

DUCT STATIC PRESSURE

- _____ in. w.c. on heating speed
- _____ in. w.c. on cooling speed
- _____ Air temperature rise

CONDENSATE LINE

- _____ Trap filled with water
- _____ Vented
- _____ Sloped toward drain
- _____ Condensate drain line hoses connected and clamped
- _____ Freeze protection (if necessary)

VENTING – DIRECT VENT

- _____ in. diameter – intake pipe
- _____ in. diameter – exhaust pipe
- _____ ft. of pipe – intake air
- _____ no. of elbows – intake air
- _____ ft. of pipe – exhaust pipe
- _____ no. of elbows – exhaust pipe
- _____ Exhaust vent temp.

TERMINATIONS – DIRECT VENT

VERTICAL

- _____ Intake – 12" min. above roof/snow level
- _____ Correct relationship – exhaust to intake

HORIZONTAL/VERTICAL – CONCENTRIC (RXGY-E03)

- _____ Intake – 12" min. above roof/snow level
- _____ Intake “Y” rotated above center
- _____ Exhaust sloped toward furnace

HORIZONTAL – STANDARD (RXGY-D02, -D03)

- _____ Correct relationship – exhaust to intake
- _____ 12" min. above grade/snow level

HORIZONTAL – ALTERNATE (RXGY-D02, -D03 OR -D04)

- _____ Correct relationship – exhaust to intake
- _____ Above anticipated snow level

VENTING – NON-DIRECT VENT

- _____ in. diameter – exhaust pipe
- _____ ft. of pipe – exhaust
- _____ no. of elbows

TERMINATION – NON-DIRECT VENT

VERTICAL

- _____ 12" min. above roof/snow level

HORIZONTAL – STANDARD

- _____ 12" min. above grade/snow level

HORIZONTAL – ALTERNATE

- _____ Above anticipated snow level
- _____ Model Number
- _____ Serial #
- _____ Date of Installation

CONTENTS

Safety Precautions	1
Installation Check List	2
General Information.....	4
Safety Information	5
Location Requirements and Considerations	6
Ducting	11
Venting and Combustion Air Piping	12
Combustion and Ventilation Air	14
Vent Pipe Installation.....	17
Condensate Drain/Neutralizer.....	29
Converting Downflow to Horizontal	31
Gas Supply and Piping.....	33
Electrical Wiring.....	39
Accessories	40
Start-Up Procedures.....	43
Air Flow.....	45
Maintenance.....	49
Troubleshooting.....	52
Wiring Diagrams.....	56

IMPORTANT: TO INSURE PROPER INSTALLATION AND OPERATION OF THIS PRODUCT, COMPLETELY READ ALL INSTRUCTIONS PRIOR TO ATTEMPTING TO ASSEMBLE, INSTALL, OPERATE, MAINTAIN OR REPAIR THIS PRODUCT. UPON UNPACKING OF THE FURNACE, INSPECT ALL PARTS FOR DAMAGE PRIOR TO INSTALLATION AND START-UP.

GENERAL INFORMATION

The (-)GRA/(-)GRJ and (-)GTA/(-)GTJ series furnaces are design-certified by CSA for use with natural and propane gases as follows:

1. As non-direct vent central forced air furnaces taking combustion air from the installation area or using air ducted from the outside.
2. As direct vent central forced air furnaces with all combustion air supplied directly to the furnace burners through a special air intake system outlined in these instructions.

Install this furnace in accordance with the American National Standard Z223.1 – latest edition entitled “National Fuel Gas Code” (NFPA54) and requirements or codes of the local utilities or other authorities having jurisdiction. This is available from the following:

National Fire Protection Association, Inc.
 Batterymarch Park
 Quincy, MA 02269

CSA-INTERNATIONAL
 8501 East Pleasant Valley Road
 Cleveland, Ohio 44131-5575

Install units in Canada in accordance with CSA-B149, local installation codes and authorities having jurisdiction. CSA-B149 is available from:

CSA-INTERNATIONAL
 178 Rexdale Blvd.
 Toronto, Ontario
 Canada M9W, 1R3

FIGURE 1
UPFLOW FURNACE

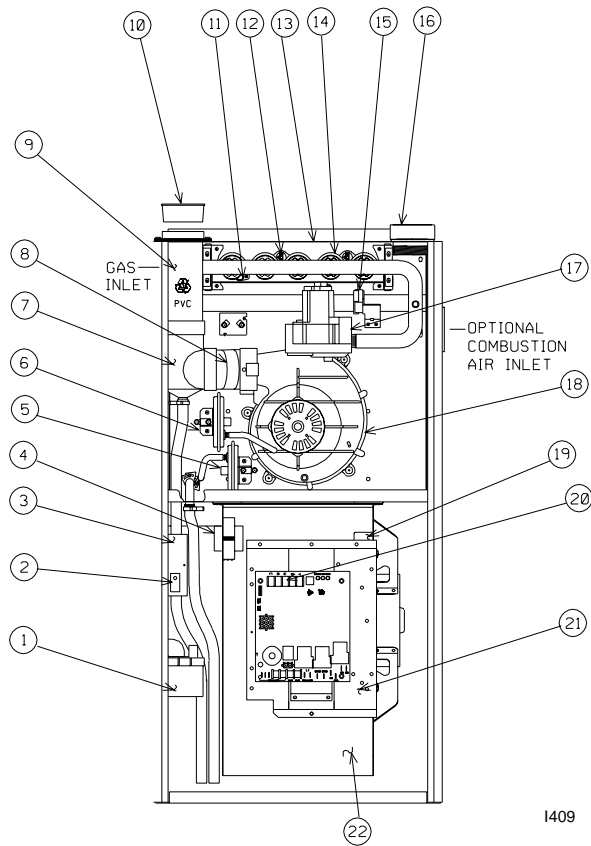

ITEM NO.	PART NAME	ITEM NO.	PART NAME
1	CONDENSATE TRAP	13	TOP PLATE
2	DOOR SWITCH	14	BURNER
3	JUNCTION BOX	15	IGNITER (HSI ONLY)
4	TRANSFORMER	16	COMBUSTION AIR INLET
5	BLOCKED DRAIN PRESSURE SWITCH	17	GAS VALVE
6	MAIN PRESSURE SWITCH	18	INDUCED DRAFT BLOWER
7	EXHAUST TRANSITION	19	CAPACITOR
8	CONNECTOR	20	LOW VOLTAGE (THERMOSTAT) TERMINAL
9	OUTLET AIR PIPE	21	CONTROL MOUNTING PLATE
10	SHIPPING PLUG	22	BLOWER
11	FLAME SENSOR		
12	OVERTEMPERATURE SWITCH		

FIGURE 2
DOWNFLOW/HORIZONTAL FURNACE

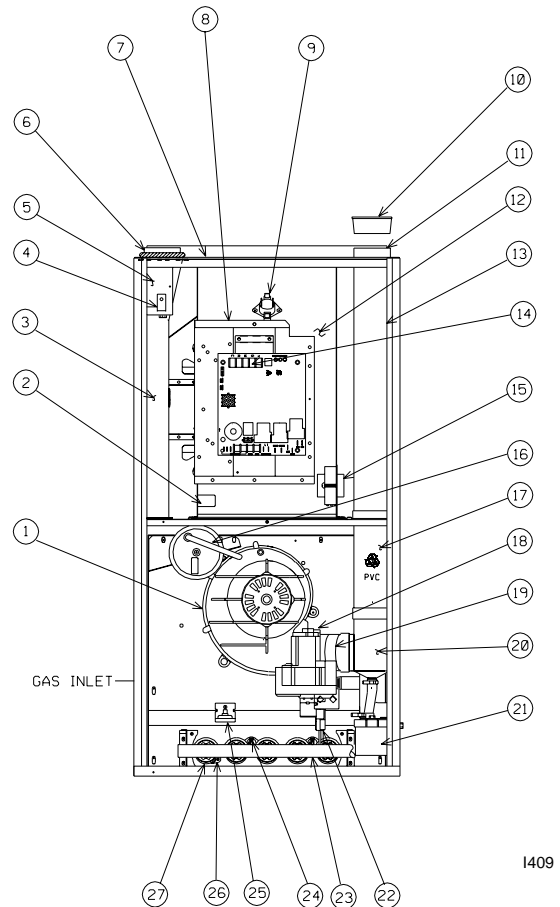

ITEM NO.	PART NAME	ITEM NO.	PART NAME
1	INDUCED DRAFT BLOWER	14	LOW VOLTAGE TERMINAL (THERMOSTAT)
2	CAPACITOR	15	TRANSFORMER
3	INLET AIR CHASE	16	PRESSURE SWITCH
4	DOOR SWITCH	17	OUTLET AIR PIPE
5	JUNCTION BOX	18	GAS VALVE
6	INLET PIPE CONNECTOR	19	CONNECTOR
7	TOP PLATE	20	EXHAUST TRANSITION
8	CONTROL MOUNTING PLATE	21	CONDENSATE TRAP
9	AUXILIARY LIMIT	22	IGNITER (HSI)
10	SHIPPING PLUG	23	MANIFOLD
11	EXHAUST CONNECTION	24	OVERTEMPERATURE SWITCH
12	BLOWER	25	ROLLOUT SWITCH
13	EXHAUST PIPE EXTENSION	26	FLAME SENSOR
		27	BURNER

SAFETY INFORMATION

▲ WARNING

USE ONLY WITH TYPE OF GAS APPROVED FOR THIS FURNACE. REFER TO THE FURNACE RATING PLATE.

▲ WARNING

INSTALL THIS FURNACE ONLY IN A LOCATION AND POSITION AS SPECIFIED IN THE LOCATION REQUIREMENTS AND CONSIDERATIONS SECTION OF THESE INSTRUCTIONS. PROVIDE ADEQUATE COMBUSTION AND VENTILATION AIR TO THE FURNACE SPACE AS SPECIFIED IN THE VENTING SECTION OF THESE INSTRUCTIONS.

▲ WARNING

PROVIDE ADEQUATE COMBUSTION AND VENTILATION AIR TO THE FURNACE SPACE AS SPECIFIED IN THE COMBUSTION AND VENTILATION AIR SECTION OF THESE INSTRUCTIONS.

▲ WARNING

COMBUSTION PRODUCTS MUST BE DISCHARGED OUTDOORS. CONNECT THIS FURNACE TO AN APPROVED VENT SYSTEM ONLY, AS SPECIFIED IN VENT PIPE INSTALLATION SECTION OF THESE INSTRUCTIONS.

▲ WARNING

DO NOT INSTALL THIS FURNACE IN A MOBILE HOME!! THIS FURNACE IS NOT APPROVED FOR INSTALLATION IN A MOBILE HOME. DOING SO COULD CAUSE FIRE, PROPERTY DAMAGE, PERSONAL INJURY OR DEATH.

▲ WARNING

NEVER TEST FOR GAS LEAKS WITH AN OPEN FLAME. USE A COMMERCIALY AVAILABLE SOAP SOLUTION MADE SPECIFICALLY FOR THE DETECTION OF LEAKS TO CHECK ALL CONNECTIONS, AS SPECIFIED IN GAS SUPPLY AND PIPING SECTION OF THESE INSTRUCTIONS.

▲ WARNING

ALWAYS INSTALL FURNACE TO OPERATE WITHIN THE FURNACE'S INTENDED TEMPERATURE-RISE RANGE WITH A DUCT SYSTEM WHICH HAS AN EXTERNAL STATIC PRESSURE WITHIN THE ALLOWABLE RANGE, AS SPECIFIED IN DUCTING SECTION OF THESE INSTRUCTIONS. SEE ALSO FURNACE RATING PLATE.

▲ WARNING

WHEN A FURNACE IS INSTALLED SO THAT SUPPLY DUCTS CARRY AIR CIRCULATED BY THE FURNACE TO AREAS OUTSIDE THE SPACE CONTAINING THE FURNACE, THE RETURN AIR SHALL ALSO BE HANDLED BY DUCT(S) SEALED TO THE FURNACE CASING AND TERMINATING OUTSIDE THE SPACE CONTAINING THE FURNACE.

▲ WARNING

WHEN THIS FURNACE IS INSTALLED IN A RESIDENTIAL GARAGE, IT MUST BE INSTALLED SO THE BURNERS AND IGNITION SOURCE ARE LOCATED NO LESS THAN 18 INCHES ABOVE THE FLOOR. THIS IS TO REDUCE THE RISK OF IGNITING FLAMMABLE VAPORS WHICH MAY BE PRESENT IN A GARAGE. ALSO, THE FURNACE MUST BE LOCATED OR PROTECTED TO AVOID PHYSICAL DAMAGE BY VEHICLES. FAILURE TO FOLLOW THESE WARNINGS CAN CAUSE A FIRE OR EXPLOSION, RESULTING IN PROPERTY DAMAGE, PERSONAL INJURY OR DEATH.

▲ WARNING

DO NOT USE THIS FURNACE DURING CONSTRUCTION IF AIR LADEN CORROSIVE COMPOUNDS ARE PRESENT SUCH AS CHLORINE AND FLUORINE. OTHERWISE, PROVISIONS MUST BE TAKEN TO PROVIDE CLEAN, UNCONTAMINATED COMBUSTION AND VENTILATION AIR TO THE FURNACE. FURNACE COMBUSTION AND VENTILATION AIR CONTAMINATED WITH THESE COMPOUNDS FORMS ACIDS DURING COMBUSTION WHICH CORRODES THE HEAT EXCHANGER AND COMPONENT PARTS. SOME OF THESE CONTAMINANTS ARE FOUND IN, BUT NOT LIMITED TO, PANELING, DRY WALL, ADHESIVES, PAINTS, STAINS, VARNISHES, SEALERS, AND MASONRY CLEANING MATERIALS.

LOCATION REQUIREMENTS AND CONSIDERATIONS

GENERAL INFORMATION

▲ WARNING

DO NOT USE THIS FURNACE DURING CONSTRUCTION IF AIR LADEN CORROSIVE COMPOUNDS ARE PRESENT SUCH AS CHLORINE AND FLUORINE. OTHERWISE, PROVISIONS MUST BE TAKEN TO PROVIDE CLEAN, UNCONTAMINATED COMBUSTION AND VENTILATION AIR TO THE FURNACE. FURNACE COMBUSTION AND VENTILATION AIR CONTAMINATED WITH THESE COMPOUNDS FORMS ACIDS DURING COMBUSTION WHICH CORRODES THE HEAT EXCHANGER AND COMPONENT PARTS. SOME OF THESE CONTAMINANTS ARE FOUND IN, BUT NOT LIMITED TO, PANELING, DRY WALL, ADHESIVES, PAINTS, STAINES, VARNISHES, SEALERS, AND MASONRY CLEANING MATERIALS.

▲ WARNING

DO NOT INSTALL THIS FURNACE IN A MOBILE HOME!! This furnace is not approved for installation in a mobile home. Doing so could cause FIRE, PROPERTY DAMAGE, PERSONAL INJURY OR DEATH.

▲ WARNING

WHEN THIS FURNACE IS INSTALLED IN A RESIDENTIAL GARAGE, IT MUST BE INSTALLED SO THE BURNERS AND IGNITION SOURCE ARE LOCATED NO LESS THAN 18 INCHES ABOVE THE FLOOR. THIS IS TO PREVENT THE RISK OF IGNITING FLAMMABLE VAPORS WHICH MAY BE PRESENT IN A GARAGE. ALSO, THE FURNACE MUST BE LOCATED OR PROTECTED TO AVOID PHYSICAL DAMAGE BY VEHICLES. FAILURE TO FOLLOW THESE WARNINGS CAN CAUSE A FIRE OR EXPLOSION, RESULTING IN PROPERTY DAMAGE, PERSONAL INJURY OR DEATH.

1. **IMPORTANT:** If installing the unit over a finished ceiling or living area, be certain to install an auxiliary condensate drain pan under the entire unit. This auxiliary drain pan should extend under any evaporator coil installed with the furnace and the open portion of the condensate drain assembly. See "Condensate Drain/Neutralizer" section for more details.
2. **IMPORTANT:** If using a cooling evaporator coil with this furnace:
 - a. be sure the air passes over the heat exchanger before passing over the cooling coil. The cooled air passing over the warm ambient air inside the heat exchanger tubes can cause condensation inside the tubes resulting in corrosion and eventual failure.
 - b. install a parallel duct system to divert all the air from the furnace allowing it to pass over the cooling coil only. Use dampers or other means to prevent chilled air from passing over the heat exchanger.

If these are manual dampers, they must be equipped to prevent heating or cooling operation unless the damper is in the full heat or cool position.

3. **IMPORTANT:** Install the furnace level. If it is not level, condensate cannot drain properly, possibly causing furnace shut down.

NOTE: These furnaces are approved for installation in attics, as well as alcoves, utility rooms, closets and crawlspaces. Provisions must be made to prevent freezing of condensate.

4. ▲ CAUTION

If this furnace is installed in a garage, attic and/or any unconditioned space, install a self-regulating heat tape around the condensate trap and along the entire length of the condensate drain in the unconditioned space. See Figure 3.

When the condensing horizontal gas furnace is installed in an unconditioned space where the temperature would be capable of reaching close to or below 32°F (0°C), a self-regulating heat tape is required on the condensate drain, along with an insulation wrap. The heat tape should meet the following requirements:

- a. The heat tape must be UL listed.
- b. The heat tape must be installed per the manufacturer's instructions for the entire length of drain pipe in the unconditioned space.

FIGURE 3
HORIZONTAL FURNACE W/HEAT TAPE ON CONDENSATE TRAP

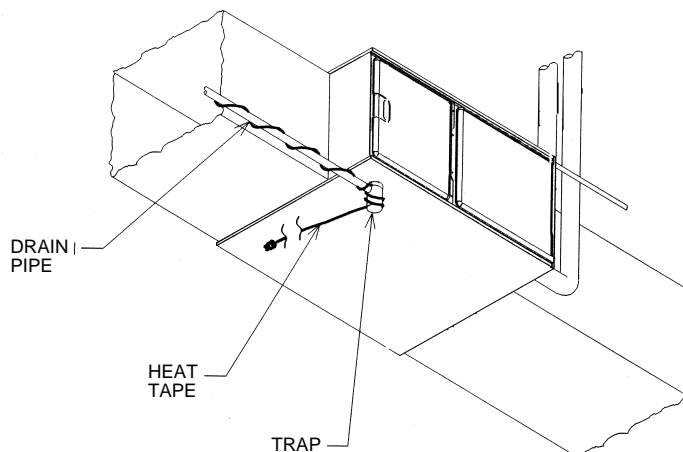

1526

- c. The heat tape should be rated at 5 or 6 watts per foot at 120V.

IMPORTANT: Support this unit when installed. Since this furnace is suitable for attic or crawl space installation, it may be installed on combustible wood flooring or by using support brackets. See Figure 4.

5. **IMPORTANT:** If installing in a utility room, be sure the door is wide enough to:
- allow the largest part of the furnace to pass; or
 - allow any other appliance (such as a water heater) to pass.
6. **IMPORTANT:** This furnace is not approved or recommended for installation on its back, with access doors facing upwards.

CLEARANCE - ACCESSIBILITY

The design of forced air furnaces with input ratings as listed in the tables under Figures 5, 6, and 7 are certified by CSA-International for the clearances to combustible materials shown in inches.

See name/rating plate and clearance label for specific model number and clearance information.

Service clearance of at least 24 inches is recommended in front of all furnaces.

NOTE: Use recommended 24" clearance if accessibility clearances are greater than fire protection clearances.

▲ WARNING

UPFLOW AND HORIZONTAL FURNACES ARE DESIGN-CERTIFIED FOR INSTALLATION ON COMBUSTIBLE FLOORS. NOTE, HOWEVER, THAT FURNACES MUST NOT BE INSTALLED DIRECTLY ON CARPETING, TILE OR OTHER COMBUSTIBLE MATERIAL OTHER THAN WOOD FLOORING. INSTALLATION ON A COMBUSTIBLE MATERIAL CAN RESULT IN FIRE, CAUSING PROPERTY DAMAGE, PERSONAL INJURY OR DEATH.

FIGURE 4
HORIZONTAL FURNACE INSTALLED W/SUPPORT BRACKETS

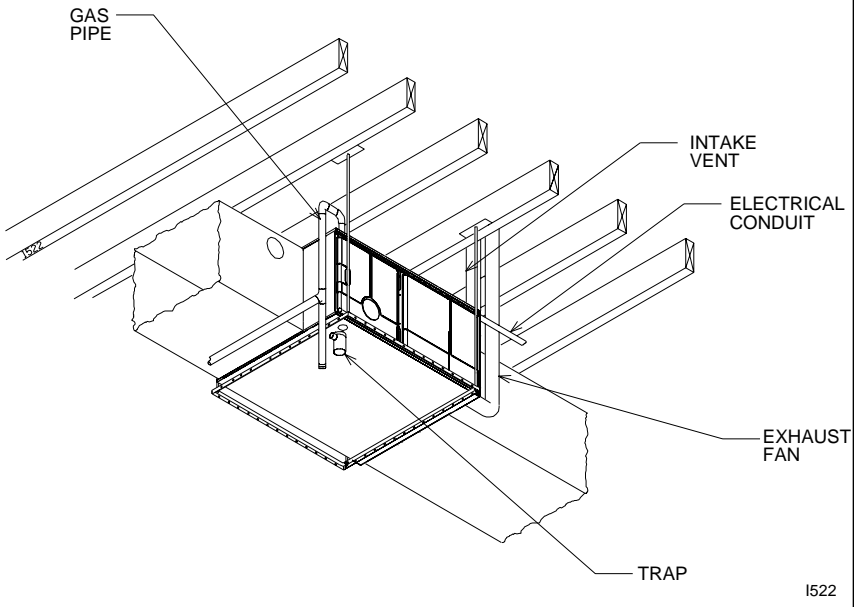

Upflow furnaces are shipped with a bottom closure panel installed. When bottom return air is used, remove the panel by removing the two screws attaching the panel to the front base angle. See Figure 50.

SITE SELECTION

- Select a site in the building near the center of the proposed, or existing, duct system.
- Give consideration to the vent system piping when selecting the furnace location. Be sure the venting system can get from the furnace to the termination with minimal length and elbows.
- Locate the furnace near the existing gas piping. Or, if running a new gas line, locate the furnace to minimize the length and elbows in the gas piping.
- Locate the furnace to maintain proper clearance to combustibles as shown in the following tables.

▲ WARNING

DO NOT LIFT THE UNIT BY THE HEAT EXCHANGER TUBES. DOING SO CAN CRACK THE HEAT EXCHANGER ASSEMBLY AND CAUSE CO₂ TO BE RELEASED INTO THE ENVIRONMENT, WHICH CAN RESULT IN PERSONAL INJURY OR DEATH.

▲ WARNING

COMBUSTIBLE MATERIAL MUST NOT BE PLACED ON OR AGAINST THE FURNACE JACKET. THE AREA AROUND THE FURNACE MUST BE KEPT CLEAR AND FREE OF ALL COMBUSTIBLE MATERIALS INCLUDING GASOLINE AND OTHER FLAMMABLE VAPORS AND LIQUIDS. PLACEMENT OF COMBUSTIBLE MATERIALS ON, AGAINST OR AROUND THE FURNACE JACKET CAN CAUSE AN EXPLOSION OR FIRE RESULTING IN PROPERTY DAMAGE, PERSONAL INJURY OR DEATH. THE HOMEOWNER SHOULD BE CAUTIONED THAT THE FURNACE AREA MUST NOT BE USED AS A BROOM CLOSET OR FOR ANY OTHER STORAGE PURPOSES.

FIGURE 5
CLEARANCE TO COMBUSTIBLES, UPFLOW UNITS

MODEL	UPFLOW MODELS						MINIMUM CLEARANCE (IN.)					SHIP WGT'S	
	A	B	C	D	E	F	LEFT SIDE	RIGHT SIDE	BACK	TOP	FRONT		VENT
04	17 1/2	16 11/32	15 5/8	2	15	13 25/32	0	0	0	1	2*	0	111
06	17 1/2	16 11/32	15 5/8	2	15	13 25/32	0	0	0	1	2*	0	117
07	17 1/2	16 11/32	15 5/8	2	15	13 25/32	0	0	0	1	2*	0	123
09	21	19 27/32	19 1/8	2	18 1/2	17 9/32	0	0	0	1	2*	0	148
10	21	19 27/32	19 1/8	2	18 1/2	17 9/32	0	0	0	1	2*	0	152
12	24 1/2	23 11/32	22 5/8	2	22	20 25/32	0	0	0	1	2*	0	160

*A service clearance of at least 24 inches is recommended in front of all furnaces.

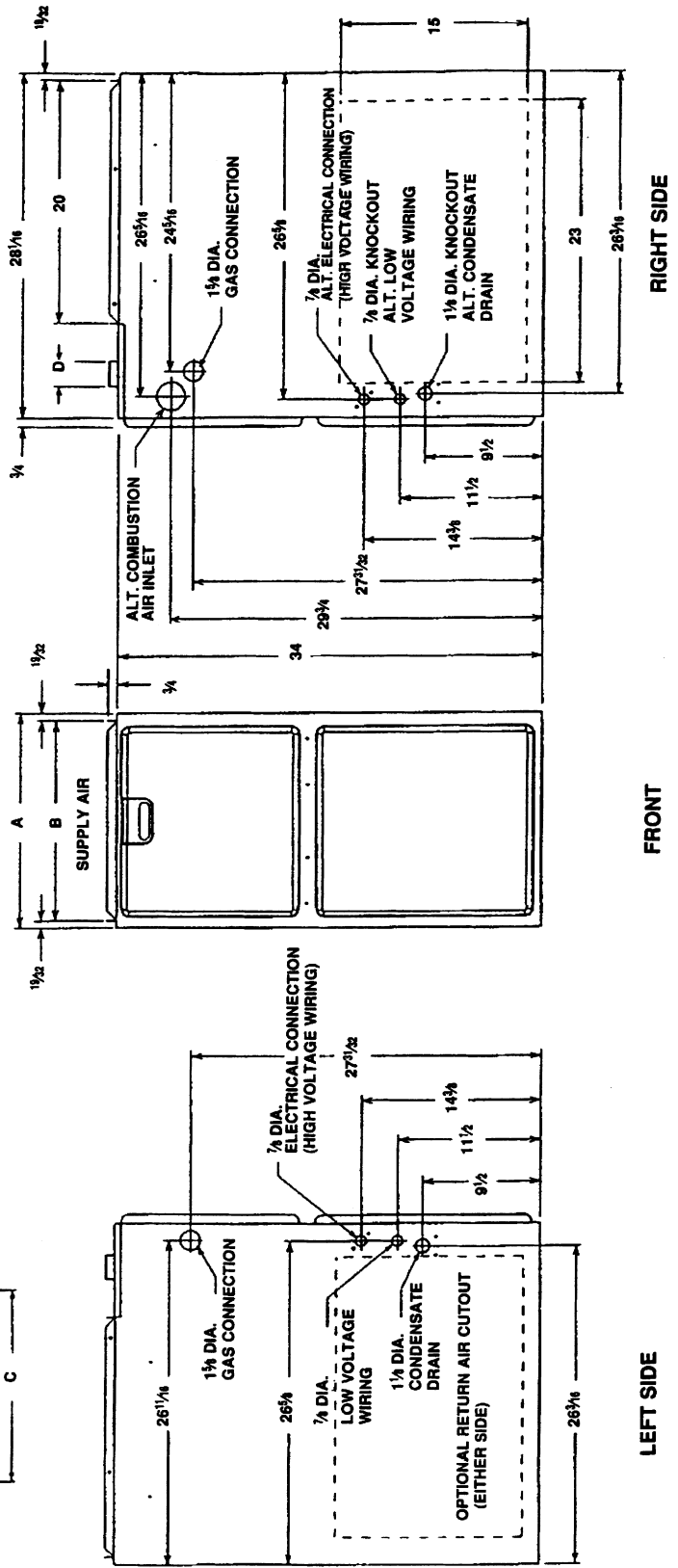
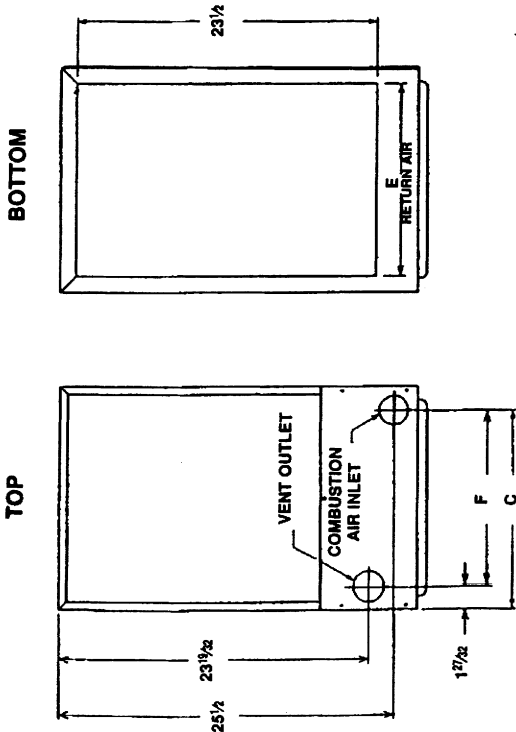
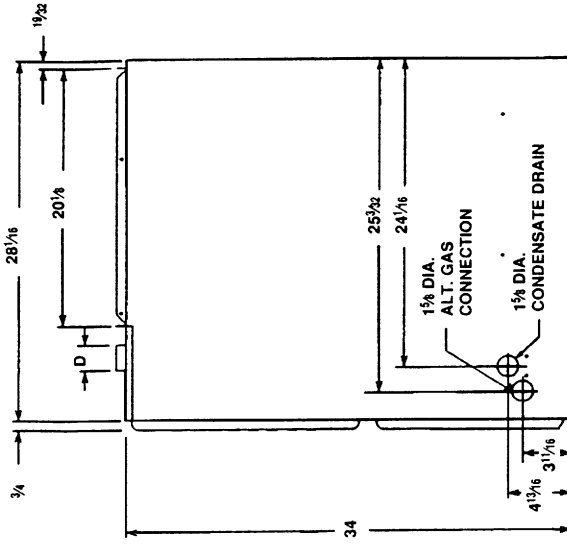
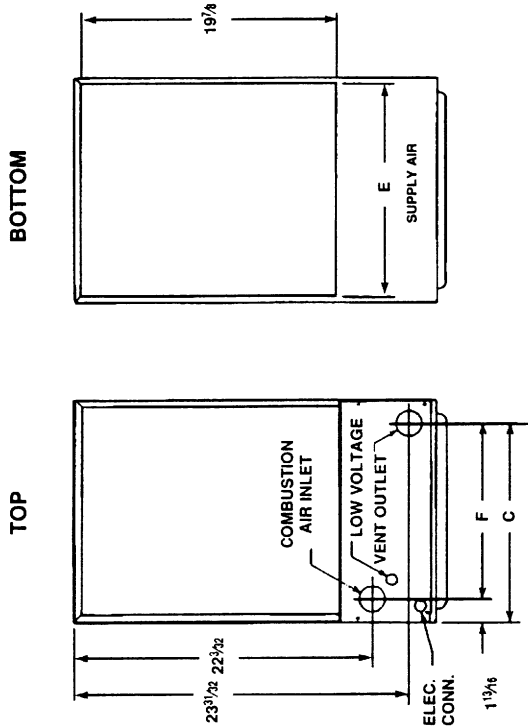

FIGURE 6
CLEARANCE TO COMBUSTIBLES, DOWNFLOW UNITS

MODEL	DOWNFLOW MODELS						MINIMUM CLEARANCE (IN.)					SHIP WGT'S	
	A	B	C	D	E	F	LEFT SIDE	RIGHT SIDE	BACK	TOP	FRONT		VENT
04	17½	16 ¹¹ / ₃₂	15½	2	16½	13¾	0	0	0	1	2*	0	111
06	17½	16 ¹¹ / ₃₂	15½	2	16½	13¾	0	0	0	1	2*	0	117
07	17½	16 ¹¹ / ₃₂	15½	2	16½	13¾	0	0	0	1	2*	0	123
09	21	19 ¹¹ / ₃₂	19¾	2	20½	17¾	0	0	0	1	2*	0	148
10	21	19 ¹¹ / ₃₂	19¾	2	20½	17¾	0	0	0	1	2*	0	152
12	24½	23 ¹¹ / ₃₂	22½	2	23½	20¾	0	0	0	1	2*	0	160

*A service clearance of at least 24 inches is recommended in front of all furnaces.



RIGHT SIDE

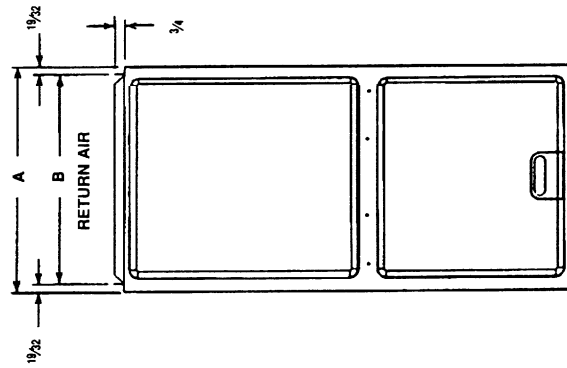

FRONT

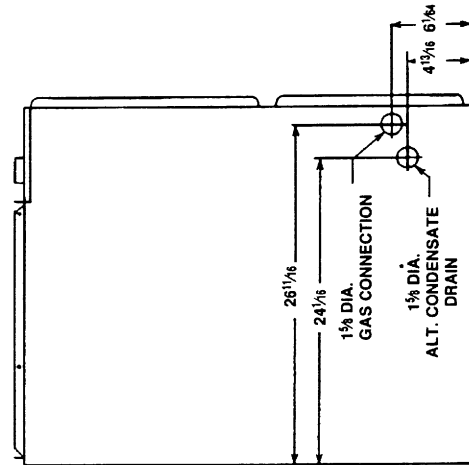

LEFT SIDE

NOTE: IN DOWNFLOW CONFIGURATION, OPTIONAL AIR CUTOFF IS NOT PERMITTED.

FIGURE 7
CLEARANCE TO COMBUSTIBLES, HORIZONTAL UNITS

MODEL	DOWNFLOW MODELS						MINIMUM CLEARANCE (IN.)					SHIP WGTs	
	A	B	C	D	E	F	LEFT SIDE	RIGHT SIDE	BACK	TOP	FRONT		VENT
04	17 1/2	16 1/32	15 5/8	2	16 5/8	13 7/8	0	0	0	1	2*	0	111
06	17 1/2	16 1/32	15 5/8	2	16 5/8	13 7/8	0	0	0	1	2*	0	117
07	17 1/2	16 1/32	15 5/8	2	16 5/8	13 7/8	0	0	0	1	2*	0	123
07	21	19 7/32	19 3/16	2	20 1/8	17 3/8	0	0	0	1	2*	0	123
09	21	19 7/32	19 3/16	2	20 1/8	17 3/8	0	0	0	1	2*	0	148
10	21	19 7/32	19 3/16	2	20 1/8	17 3/8	0	0	0	1	2*	0	152
12	24 1/2	23 1/32	22 5/8	2	23 5/8	20 5/8	0	0	0	1	2*	0	160

*A service clearance of at least 24 inches is recommended in front of all furnaces.

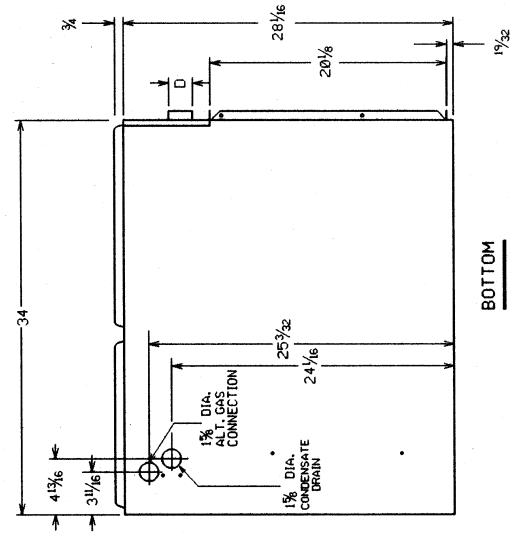
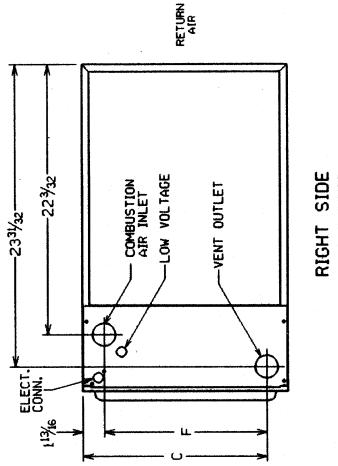
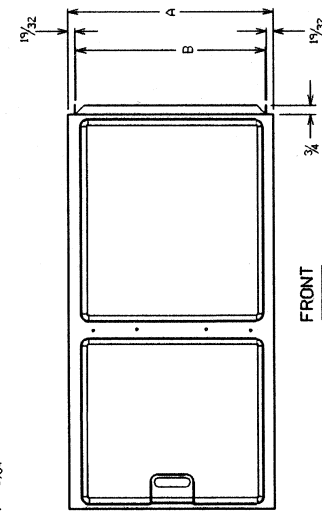
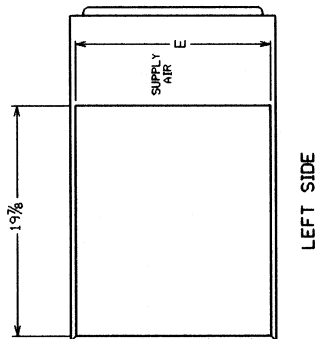
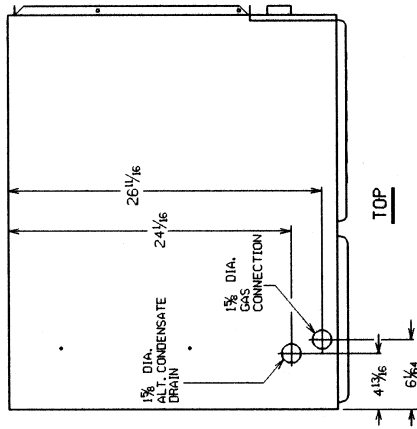

IMPORTANT: This furnace is not approved or recommended for installation on its back, with access doors facing upwards.

DUCTING

Proper air flow is required for the correct operation of this furnace. Too little air flow can cause erratic operation and can damage the heat exchanger. The duct system must carry the correct amount of air for heating and cooling if summer air conditioning is used.

Size the ducts according to acceptable industry standards and methods. The total static pressure drop of the air distribution system should not exceed 0.5" w.c.

NOTE: Return air grilles and warm air registers must not be obstructed

▲ WARNING

NEVER ALLOW THE PRODUCTS OF COMBUSTION FROM THE FLUE TO ENTER THE RETURN AIR DUCTWORK OR THE CIRCULATED AIR SUPPLY. ALL RETURN DUCTWORK MUST BE ADEQUATELY SEALED AND SECURED TO THE FURNACE WITH SHEET METAL SCREWS; AND JOINTS, TAPED. ALL OTHER DUCT JOINTS MUST BE SECURED WITH APPROVED CONNECTIONS AND SEALED AIRTIGHT. WHEN AN UPFLOW FURNACE IS MOUNTED ON A PLATFORM WITH RETURN THROUGH THE BOTTOM, IT MUST BE SEALED AIRTIGHT BETWEEN THE FURNACE AND THE RETURN AIR PLENUM. THE FLOOR OR PLATFORM MUST PROVIDE SOUND PHYSICAL SUPPORT OF THE FURNACE WITHOUT SAGGING, CRACKS, OR GAPS, AROUND THE BASE, PROVIDING A SEAL BETWEEN THE SUPPORT AND THE BASE.

FAILURE TO PREVENT PRODUCTS OF COMBUSTION FROM BEING CIRCULATED INTO THE LIVING SPACE CAN CREATE POTENTIALLY HAZARDOUS CONDITIONS, INCLUDING CARBON MONOXIDE POISONING THAT COULD RESULT IN PERSONAL INJURY OR DEATH.

DO NOT, UNDER ANY CIRCUMSTANCES, CONNECT RETURN OR SUPPLY DUCTWORK TO OR FROM ANY OTHER HEAT PRODUCING DEVICE SUCH AS A FIREPLACE INSERT, STOVE, ETC. DOING SO MAY RESULT IN FIRE, CARBON MONOXIDE POISONING, EXPLOSION, PERSONAL INJURY OR PROPERTY DAMAGE.

IMPORTANT: Some high efficiency filters have a greater than normal resistance to air flow. This can adversely affect furnace operation. **BE SURE TO CHECK AIR FLOW.**

IMPORTANT: When using outside air, design and adjust the system to maintain a return air temperature ABOVE 50° F during the heating season.

UPFLOW UNITS

1. Position the unit to minimize long runs of duct or runs of duct with many turns and elbows.
2. Open the return air compartment.

▲ WARNING

UPFLOW FURNACE: A SOLID METAL BASE PLATE MUST BE INSTALLED IN THE FURNACE BOTTOM WHEN USING SIDE RETURN. FAILURE TO INSTALL A BASE PLATE COULD CAUSE THE PRODUCTS OF COMBUSTION TO CIRCULATE INTO THE LIVING SPACE AND CREATE POTENTIALLY HAZARDOUS CONDITIONS, INCLUDING CARBON MONOXIDE POISONING OR DEATH.

- a. Cut an opening in the side. The opening should be cut the full width of the knockouts on the unit. See Figure 8.

NOTE: Where the maximum air flow is 1800 CFM or more, both sides or the bottom must be used for return air.

3. Connect the return duct or return air cabinet to the unit. Make the connection air tight to prevent entraining combustion gases from an adjacent fuel-burning appliance.
4. Be sure to have adequate space for the unit filter.

NOTE: DO NOT take return air from bathrooms, kitchens, furnace rooms, garages, utility or laundry rooms, or cold areas.

NOTE: DO NOT use a rear air return.

5. If summer air conditioning is desired, position the indoor coil on the top of the unit. Insure that no air can bypass this coil.
6. Connect the supply air plenum to the furnace plenum opening.

IMPORTANT: If a flexible duct connector must be used, it **MUST** be rated for a minimum temperature of **250°F. continuous.**

DOWNFLOW UNITS

1. Position the unit to minimize long runs of duct or runs of duct with many turns and elbows.
2. If summer air conditioning is desired, position the indoor coil on the bottom of the unit. Insure that no air can bypass this coil.
3. If installing on a combustible floor and not using an air conditioning plenum, install the special non-combustible floor base. See Figure 9.

▲ WARNING

THE DOWNFLOW FURNACE DESIGN IS CERTIFIED FOR INSTALLATION ON A NON-COMBUSTIBLE FLOOR. USE THE SPECIAL BASE SPECIFIED ON THE FURNACE CLEARANCE LABEL. FAILURE TO INSTALL THE SPECIAL BASE MAY RESULT IN FIRE, PROPERTY DAMAGE, PERSONAL INJURY OR DEATH. THIS SPECIAL BASE IS SHIPPED FROM THE FACTORY AS AN ACCESSORY.

FIGURE 8

**CUTOUT AND DRILL INFORMATION
JACKET**

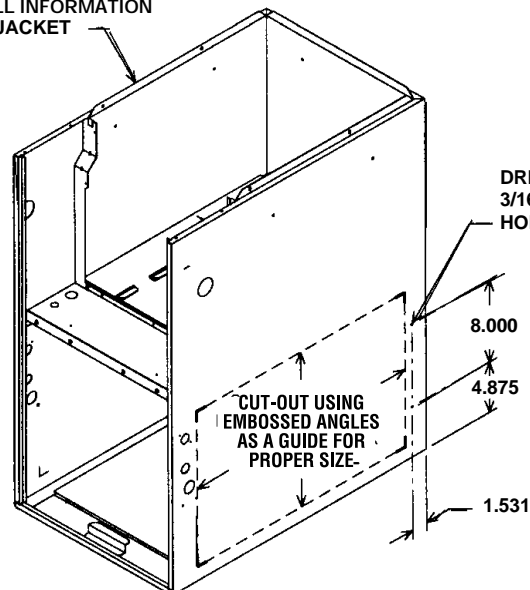

4. Connect the furnace to the supply air plenum.
5. Connect the return air ducting to the return air opening at the top of the unit. Make the connection air tight to prevent entraining combustion gases from an adjacent fuel-burning appliance.

6. **Be sure to have adequate space for the unit filter.**

NOTE: DO NOT take return air from bathrooms, kitchens, furnace rooms, garages, utility or laundry rooms, or cold areas.

4. Connect the return air ducting to the return air opening at the right end of the unit. Make the connection air tight to prevent pulling combustion gases from an adjacent fuel-burning appliance.

5. **Be sure to have adequate space for the unit filter.**

NOTE: DO NOT take return air from bathrooms, kitchens, furnace rooms, garages, utility or laundry rooms, or cold areas.

HORIZONTAL UNIT

IMPORTANT: THIS FURNACE MAY ONLY BE INSTALLED SO AS WHEN FACING THE FRONT OF THE FURNACE, SUPPLY AIR IS DISCHARGED ON THE LEFT HAND SIDE.

1. Position the unit to minimize long runs or runs with many turns and elbows.
2. If summer air conditioning is desired, position the indoor coil on the left end of the unit. Insure that no air can bypass this coil.
3. Connect the furnace to the supply air plenum.

FIGURE 9
COMBUSTIBLE FLOOR BASE

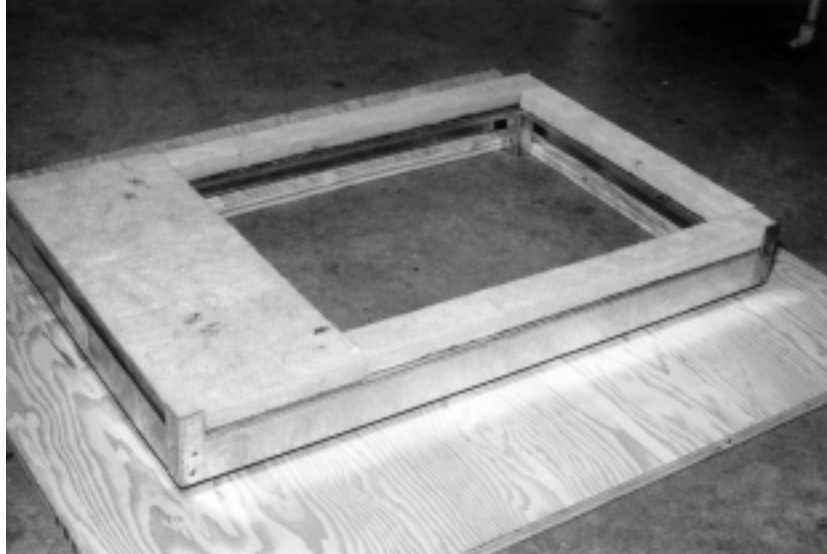

VENTING AND COMBUSTION AIR PIPING

GENERAL INFORMATION

▲ WARNING

READ AND FOLLOW ALL INSTRUCTIONS IN THIS SECTION. FAILURE TO PROPERLY VENT THIS FURNACE CAN CAUSE CARBON MONOXIDE POISONING OR AN EXPLOSION OR FIRE, RESULTING IN PROPERTY DAMAGE, PERSONAL INJURY OR DEATH.

This furnace removes both sensible and latent heat from the combustion flue gases. Removal of latent heat results in condensation of flue gas water vapor. This condensed water vapor drains from the secondary heat exchanger and out of the unit into a drain trap.

When installed as a non-direct vent furnace, only exhaust piping is required and inside combustion air may be used. Refer to section on "COMBUSTION & VENTILATION AIR FOR FURNACE INSTALLATIONS."

Direct vent installations require a dedicated combustion air and venting system. All air for combustion is taken from the outside atmosphere and all combustion products are discharged to the outdoors.

The combustion air and vent pipe fittings must conform to American National Standards Institute (ANSI) and American Society for Testing Materials (ASTM) standards D1785 (Schedule 40 PVC), D2665 (PVC-DWV), D2241 (SDR-21 and SDR26-26 PVC), D2661 (ABS-DWV) or F628 (Schedule 40 ABS-DWV).

NOTE: Cellular core PVC is also approved for use. It must be schedule 40PVC-DWV cellular pipe manufactured under ASTM F-891.

IMPORTANT: *The plastic combustion air and venting components are of Schedule 40 PVC. If using ABS piping, ensure that the solvent cement is compatible for joining PVC to ABS components or use a mechanical connection that can withstand the vent temperatures and are corrosion resistant.*

NOTE: Schedule 40 ABS-DWV pipe and fittings may be used as an alternate to PVC pipe for the combustion air inlet and vent pipes.

OVERTEMPERATURE SAFETY SWITCHES

Furnaces are equipped with safety switches in the control compartment to protect against overtemperature conditions caused by inadequate

combustion air supply. The switches for the upflow and downflow models are located in the burner compartment. If a switch is tripped it must be manually reset.

▲ WARNING

DO NOT JUMPER THESE DEVICES! IF ONE OF THESE SWITCHES SHOULD TRIP, A QUALIFIED INSTALLER, SERVICE AGENCY OR THE GAS SUPPLIER MUST BE CALLED TO CHECK AND/OR CORRECT FOR ADEQUATE COMBUSTION AIR SUPPLY. DO NOT RESET THE SWITCHES WITHOUT TAKING CORRECTIVE ACTION TO ASSURE THAT AN ADEQUATE SUPPLY OF COMBUSTION AIR IS MAINTAINED UNDER ALL CONDITIONS OF OPERATION. FAILURE TO DO SO CAN RESULT IN CARBON MONOXIDE POISONING OR DEATH. IF THIS UNIT IS MOUNTED IN A CLOSET, THE DOOR MUST BE CLOSED WHEN MAKING THIS CHECK.

REPLACE THESE SWITCHES ONLY WITH THE IDENTICAL REPLACEMENT PART.

EXISTING VENT SYSTEMS

When the installation of this furnace replaces an existing furnace that is

removed from a vent system serving other appliances, the vent system is likely to be too large to properly vent the remaining attached appliances.

The following steps should be followed with each appliance remaining connected to the original common vent system. Place the appliance to be tested in operation, while the other appliances remaining connected to the common vent system are not in operation. Test the operation of each appliance individually by the following method.

1. Permanently seal any unused openings in the common venting system.
2. Visually inspect the venting system for proper size and horizontal pitch and determine that there is no blockage, restriction, leakage, corrosion or other deficiencies which could cause an unsafe condition.
3. If practical, close all building doors, windows and all doors between the space where the appliances remaining connected to the common venting system are located.
Turn on clothes dryers and any appliance not connected to the common venting system. Turn on any exhaust fans, such as range hoods and bathroom exhausts, so they will operate at maximum speed. Do not operate a summer exhaust fan. Close fireplace dampers.
4. Follow the lighting instructions. Place the appliance being inspected into operation. Adjust the thermostat so the appliance will operate continuously.
5. Test for spillage at the draft hood relief opening after 5 minutes of main burner operation. Use the flame of a match or candle, or smoke from a cigarette, cigar or pipe.
6. After it has been determined that each appliance that remains connected to the common venting system properly vents (when tested as outlined above), return doors, windows, exhaust fans, fireplace dampers and any other gas-burning appliance to their previous conditions of use.
7. If improper venting is observed during any of the above tests, the common venting system must be resized. See vent tables in these instructions

When the furnace is installed in the same space with other gas appliances such as a water heater, be sure there is an adequate supply of combustion and ventilation air for the other appliances. Do not delete or reduce the combustion air supply required by the other gas appliances in this space. See Z223.1, National Fuel Gas Code (NFPA54) for determining the combustion air requirements for gas appliances. An unconfined space must have at least 50 cubic feet (volume) for each 1,000 BTUH of the total input of all appliances in the space. If the open space containing the appliances is in a building with tight construction (contemporary construction), outside air may still be required for the appliances to burn and vent properly. Outside air openings should be sized the same as for a confined space.

JOINING PIPE AND FITTINGS

WARNING

PVC SOLVENT CEMENTS AND PRIMERS ARE HIGHLY FLAMMABLE. PROVIDE ADEQUATE VENTILATION AND DO NOT ASSEMBLE NEAR HEAT SOURCE OR AN OPEN FLAME. DO NOT SMOKE. AVOID SKIN OR EYE CONTACT. OBSERVE ALL CAUTIONS AND WARNINGS PRINTED ON MATERIAL CONTAINERS. FAILURE TO FOLLOW THESE GUIDELINES MAY RESULT IN FIRE, EXPLOSION OR ASPHYXIATION CAUSING PERSONAL INJURY OR DEATH.

All pipe, fittings, solvent cement, primers and procedures must conform to American National Standard Institute and American Society for Testing and Materials (ANSI/ASTM) standards in the U.S.

Pipe and Fittings - ASTM-D1785, D2466, D2665, D2231, D2661 and F628.

PVC Primer and Solvent Cement - ASTM-D2564

ABS Pipe and Fittings - Use ABS Primer and Solvent Cement D2235

Procedure for Cementing Joints - ASTM-D2855

IMPORTANT: *The plastic combustion air and venting components are of PVC. If using ABS piping, ensure that the solvent cement is compatible for joining PVC to ABS components or use a mechanical connection that can withstand the vent temperatures and are corrosion resistant.*

CEMENTING JOINTS

Properly seal all joints in the PVC vent using the following materials and procedures.

PVC CLEANER-PRIMER AND PVC MEDIUM-BODY SOLVENT CEMENT

IMPORTANT: After cutting pipe, remove all ragged edges and burrs. This is important to prevent reduction in pressure drop throughout the system.

1. Cut pipe end square. Chamfer edge of pipe. Clean fitting socket and pipe joint area of all dirt, grease and moisture.
2. After checking pipe and socket for proper fit, wipe socket and pipe with cleaner-primer. Apply a liberal coat of primer to inside surface of socket and outside of pipe. Read instructions included with the primer for proper application.
3. Apply a thin coat of cement evenly in the socket. Quickly apply a heavy coat of cement to the pipe end and insert pipe into fitting with a slight twisting movement until it bottoms out.
NOTE: Cement must be fluid; if not, recoat.
4. Hold the pipe in the fitting for 30 seconds to prevent the tapered socket from pushing the pipe out of the fitting.
5. Wipe all excess cement from the joint with a rag. Allow 15 minutes before handling. Cure time varies according to fit, temperature and humidity.

NOTE: Stir the solvent cement frequently while using. Use a natural bristle brush or the dauber supplied with the can. The proper brush size is one inch.

IMPORTANT: *For Proper Installation*

DO NOT use solvent cement that has become curdled, lumpy or thickened.

DO NOT thin. Observe shelf precautions printed on containers.

For application below 32°F, use only low-temperature-type solvent cement.

COMBUSTION AND VENTILATION AIR

NON-DIRECT FURNACE INSTALLATIONS

▲ WARNING

THE FURNACE AND ANY OTHER FUEL-BURNING APPLIANCE MUST BE PROVIDED WITH ENOUGH FRESH AIR FOR PROPER COMBUSTION AND VENTILATION OF THE FLUE GASES. MOST HOMES WILL REQUIRE THAT OUTSIDE AIR BE SUPPLIED INTO THE FURNACE AREA. FAILURE TO DO SO CAN CAUSE PERSONAL INJURY OR DEATH FROM CARBON MONOXIDE POISONING.

Adequate facilities for providing air for combustion and ventilation must be provided in accordance with section 5.3, "Air for Combustion and Ventilation" of the National Fuel Gas Code, ANSI Z223.1 (latest edition) or applicable provisions for the local building codes, and not obstructed so as to prevent the flow of air to the furnace.

IMPORTANT: Air for combustion and ventilation must not come from a corrosive atmosphere. Any failure due to corrosive elements in the atmosphere is excluded from warranty coverage.

The following types of installation (but not limited to the following) will require OUTDOOR AIR for combustion, due to chemical exposures:

- Commercial buildings
- Buildings with indoor pools
- Furnaces installed in laundry rooms
- Furnaces in hobby or craft rooms
- Furnaces installed near chemical storage areas.

Exposure to the following substances in the combustion air supply (but not limited to the following) will also require OUTDOOR AIR for combustion:

- Permanent wave solutions
- Chlorinated waxes and cleaners
- Chlorine-based swimming pool chemicals
- Water softening chemicals
- De-icing salts or chemicals
- Carbon tetrachloride
- Halogen type refrigerants

- Cleaning solvents (such as perchloroethylene)
- Printing inks, paint removers, varnishes, etc.
- Hydrochloric acid
- Cements and glues
- Antistatic fabric softeners for clothes dryers
- Masonry curing and acid washing materials

Combustion air must be free of acid-forming chemicals such as sulphur, fluorine and chlorine. These elements are found in aerosol sprays, detergents, bleaches, cleaning solvents, air fresheners, paint and varnish removers, refrigerants and many other commercial and household products. When burned in a gas flame, vapors from these products form acid compounds. The acid compounds increase the dew point temperature of the flue products and are highly corrosive after they condense.

▲ WARNING

ALL FURNACE INSTALLATIONS MUST COMPLY WITH THE NATIONAL FUEL GAS CODE AND LOCAL CODES TO PROVIDE ADEQUATE COMBUSTION AND VENTILATION AIR FOR THE FURNACE. FAILURE TO DO SO CAN RESULT IN EXPLOSION, FIRE, PROPERTY DAMAGE, CARBON MONOXIDE POISONING, PERSONAL INJURY OR DEATH.

Combustion air requirements are determined by whether the furnace is in an open (unconfined) area or in a confined space such as a closet or small room.

EXAMPLE 1: FURNACE LOCATED IN AN UNCONFINED SPACE

Using indoor air for combustion.

An unconfined space must have at least 50 cubic feet for each 1,000 BTUH of the total input for all appliances in the space. Here are a few examples of the room sizes required for different inputs. The sizes are based on 8-foot ceilings.

BTUH Input	Minimum Sq. Feet With 8' Ceiling	Typical Room Size With 8' Ceiling
45,000	281	14' x 20' OR 16' x 18'
60,000	375	15' x 25' OR 19' x 20'
75,000	469	15' x 31' OR 20' x 24'
90,000	563	20' x 28' OR 24' x 24'
105,000	657	20' x 33' OR 26' x 25'
120,000	750	25' x 30' OR 24' x 32'

If the open space containing the furnace is in a building with tight construction, outside air may still be required for the furnace to operate and vent properly. Outside air openings should be sized the same as for a confined space.

EXAMPLE 2: FURNACE LOCATED IN A CONFINED SPACE

A confined space (any space smaller than shown above as "unconfined") must have openings into the space which are located in accordance with the requirements set forth in the following subsections A and B. Size the openings by how they are connected to the heated area or to the outside, and by the input of all appliances in the space.

If confined space is within a building with tight construction, combustion air must be taken from outdoors or area freely communicating with the outdoors.

A. USING INDOOR AIR FOR COMBUSTION

IMPORTANT: Air should not be taken from a heated space with a fireplace, exhaust fan or other device that may produce a negative pressure.

If combustion air is taken from the heated area, the openings must each have at least 100 square inches of free area. Each opening must have at least one square inch of free area for each 1,000 BTUH of total input in the space. Here are some examples of typical openings required.

BTUH Input	Free Area Each Opening
45,000	100 square inches
60,000	100 square inches
75,000	100 square inches
90,000	100 square inches
105,000	105 square inches
120,000	120 square inches

B. USING OUTDOOR AIR FOR COMBUSTION

IMPORTANT: Do not take air from an attic space that is equipped with power ventilation.

The confined space must communicate with the outdoors in accordance with Methods 1 or 2. The minimum dimension of air openings shall not be less than 3 inches. Where ducts are used, they shall be of the same cross-sectional area as the free area of the openings to which they connect.

Method 1

Two permanent openings, one located within 12 inches of the top and one located within 12 inches of the bottom of the enclosure, shall be provided. The openings shall communicate directly, or by ducts, with the outdoors or spaces (crawl or attic) that freely communicate with the outdoors.

a. Where directly communicating with the outdoors or where communicating to the outdoors

**FIGURE 10
AIR FROM HEATED SPACE**

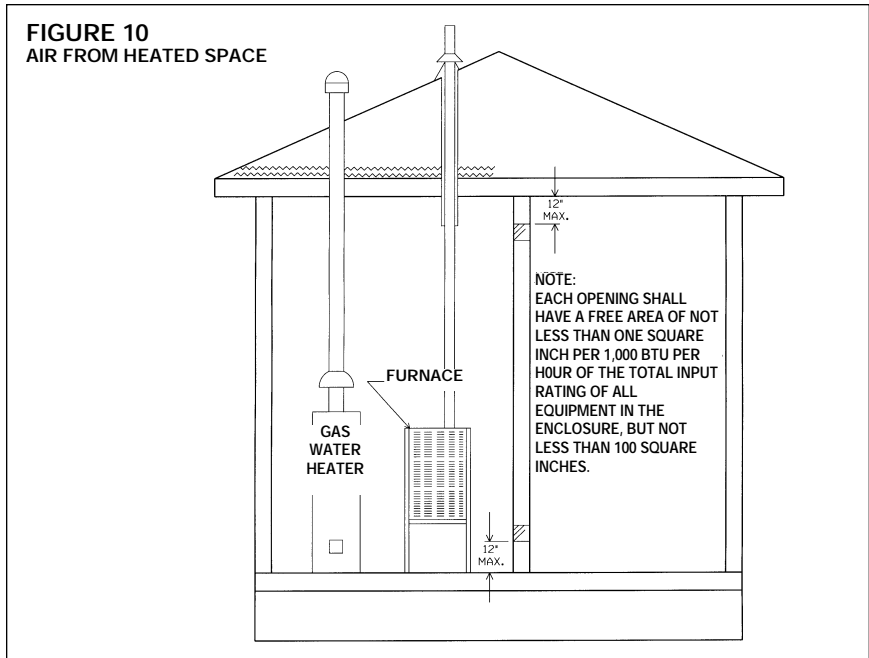

through vertical ducts as shown in Figure 11, each opening shall have a minimum free area of 1 square inch for each 4,000 BTUH of total appliance input rating in the enclosure.

BTUH Input	Free Area Each Opening	Round Pipe Size
45,000	11.25 square inches	4"
60,000	15.00 square inches	5"
75,000	18.75 square inches	5"
90,000	22.50 square inches	6"
105,000	26.25 square inches	6"
120,000	30.00 square inches	6"

b. Where communicating with outdoors through horizontal ducts, each opening shall have a minimum free area of 1 square inch for each 2,000 BTUH of total input rating of all equipment in the enclosure (See Figure 12).

Here are some typical sizes:

BTUH Input	Free Area Each Opening	Round Pipe Size
45,000	22.50 square inches	6"
60,000	30.00 square inches	6"
75,000	37.50 square inches	7"
90,000	45.00 square inches	8"
105,000	52.50 square inches	8"
120,000	60.00 square inches	9"

**FIGURE 11
AIR FROM ATTIC/CRAWL SPACE**

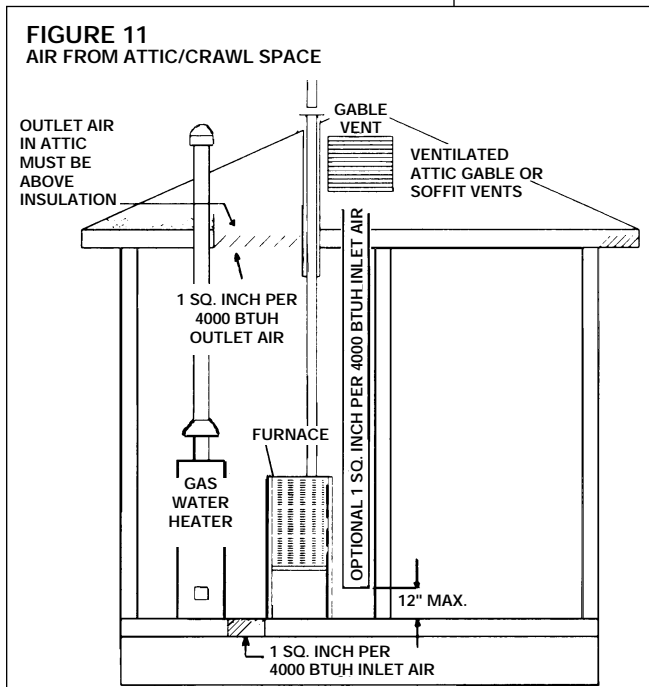

**FIGURE 12
OUTSIDE AIR USING A HORIZONTAL DUCT**

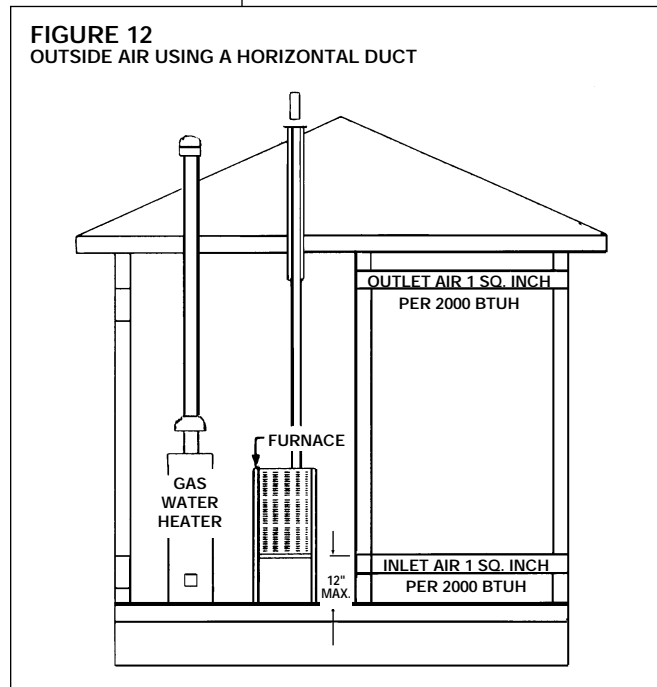

Method 2
(Not Shown)

One permanent opening, located within 12 inches of the top of the enclosure, shall be permitted where the equipment has clearances of at least 1 inch from the sides and back and 6 inches from the front of the appliance.

The opening shall directly communicate with the outdoors or communicate through a vertical or horizontal duct to the outdoors or spaces (crawl or attic) that freely communicate with the outdoors, and shall have a minimum free area of:

- a. 1 square inch for each 3,000 BTUH of the total input rating of all equipment located in the enclosure and

BTUH Input	Free Area Each Opening	Round Pipe Size
45,000	15.00 square inches	4"
60,000	16.67 square inches	5"
75,000	25.00 square inches	6"
90,000	30.00 square inches	6"
105,000	35.00 square inches	7"
120,000	40.00 square inches	7"

- b. Not less than the sum of the areas of all vent connectors in the confined space.

If unit is installed where there is an exhaust fan, sufficient ventilation must be provided to prevent the exhaust fan from creating a negative pressure.

Combustion air openings must not be restricted in any manner.

CONSULT LOCAL CODES FOR SPECIAL REQUIREMENTS.

CONNECTION TO FURNACE

IMPORTANT: When indoor combustion air is used, the inlet air opening at the furnace must be protected from accidental blockage. On upflow models, install a 90° elbow pointing downward in the side inlet air opening or a double elbow pointing downward in the top inlet air opening. On downflow/horizontal models, install a double elbow in the top inlet air opening. See Figure 13.

FIGURE 13
COMBUSTION AIR FITTING

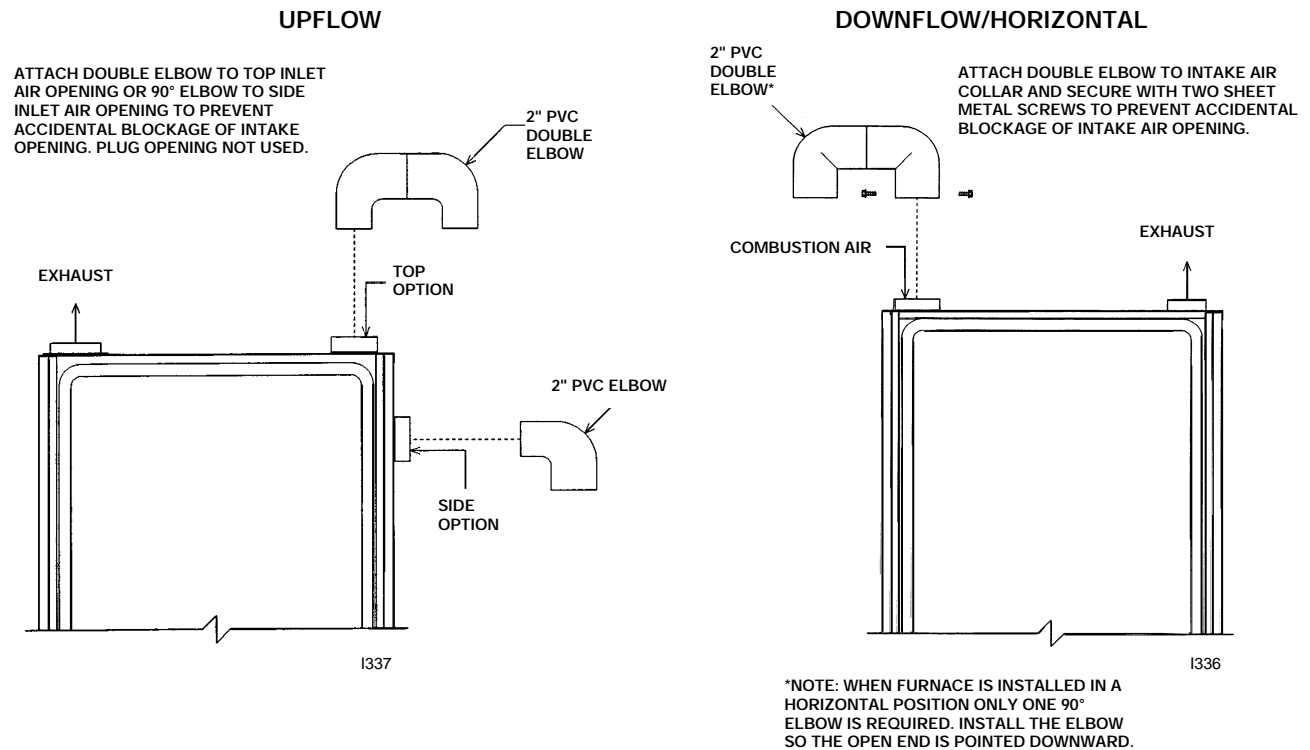

VENT PIPE INSTALLATION

NON-DIRECT VENT INSTALLATION GUIDELINES

IMPORTANT: Failure to correctly follow all venting guidelines may result in erratic furnace operation, freeze-up of combustion air or exhaust air piping or sooting of the furnace.

All exhaust piping must be installed in compliance with Part 7, "Venting of Equipment," of the latest edition of the National Fuel Gas Code NPFA54/ANSI Z223.1-, local codes or ordinances and these instructions.

1. Vertical piping is preferred.
2. All horizontal piping must slope upward a minimum of 1/4 inch per foot of run so that condensate drains toward the furnace.
3. All horizontal runs must be supported at least every 4 feet. No sags or dips are permitted.
4. **IMPORTANT:** Do not connect vent with any other appliance. Do not install in the same chase or chimney with a metal or high temperature plastic pipe from another gas or fuel-burning appliance unless the required minimum clearances to combustibles are maintained between the PVC pipe and other pipes.
5. All vent runs through unconditioned spaces where below-freezing temperatures are expected should be insulated with 1-in. thick, medium-density, foil-faced fiberglass. An equivalent "arm-a-flex" or

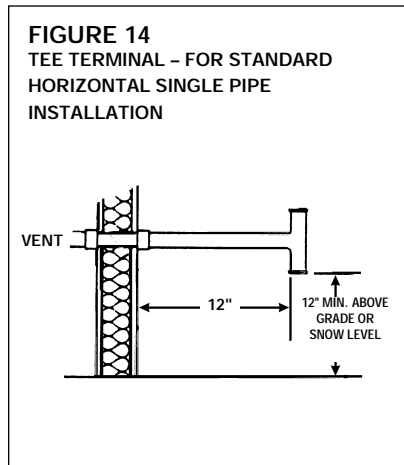

TABLE 1
FOR NON-DIRECT VENT APPLICATIONS - AIR FOR COMBUSTION PROVIDED FROM INDOORS

MAXIMUM ALLOWABLE LENGTH IN FEET OF EACH EXHAUST PIPE AND INTAKE PIPE

FURNACE INPUT	PIPE SIZE	TERMINATION	NUMBERS OF ELBOWS 45° OR 90° Medium / Long Radius ONLY		
			1-2	3-4	5-6
45,000	2"	Standard	60	55	50
		Alternate	55	50	45
60,000	2"	Standard	35	30	25
		Alternate	30	25	20
	3"	Standard	120	120	115
		Alternate	120	120	110
75,000	2"	Standard	20	15	10
		Alternate	NR	NR	NR
	3"	Standard	110	105	95
		Alternate	80	70	65
90,000	3"	Standard	90	85	75
		Alternate	60	50	45
105,000	3"	Standard	80	75	65
		Alternate	50	40	35
120,000	3"	Standard	70	65	55
		Alternate	40	30	25

NOTES:

1. *N.R. - NOT RECOMMENDED.
2. MAXIMUM OF 6 - 90 DEGREE ELBOWS MAY BE USED. DO NOT COUNT ELBOWS REQUIRED FOR ALTERNATE TERMINATION. USE ONLY MEDIUM OR LONG SWEEP ELBOWS.
3. A 45° DEGREE ELBOW IS CONSIDERED ONE ELBOW.

ELEVATED SINGLE PIPE ALTERNATE TEE TERMINATION

See Figure 15. The tee termination may be elevated up to 24 inches above the wall penetration if required for anticipated snow levels. Use 2 medium-radius, 2-in. PVC elbows and 2-in. PVC pipe, attaching the tee so it is 12 inches from the wall.

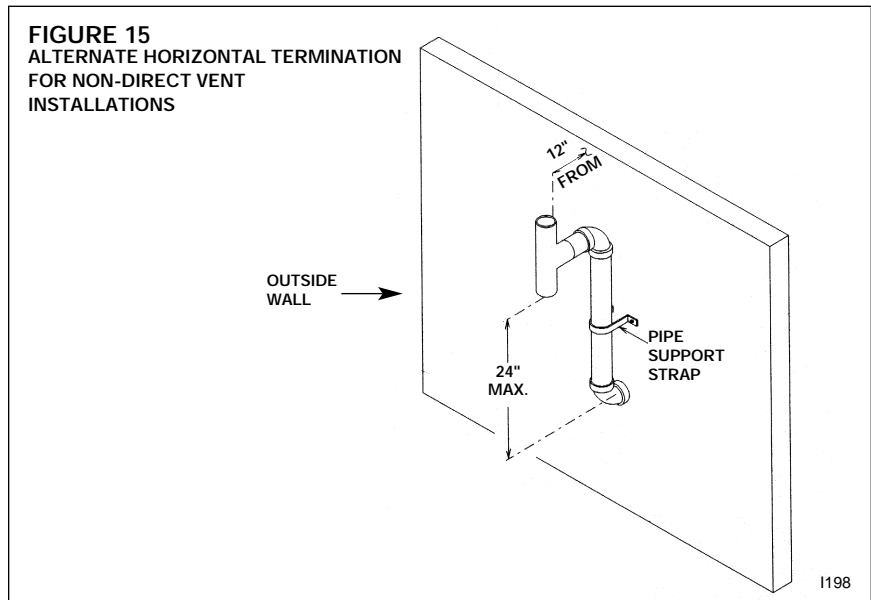

“rub-a-tex” insulation may also be used as long as there is no heat tape applied to the vent pipe. For horizontal runs where water may collect, wrap the vent pipe with self-regulating 3 or 5 watt heat tape. The heat tape must be U.L. listed and installed per the manufacturer’s instructions.

6. The minimum vent pipe length is 5 feet.

STANDARD INSTALLATIONS

The single-pipe system requires an exhaust pipe only. Combustion air may be taken from the furnace installation area or ducted to the furnace area from the outside.

Size the exhaust pipe as specified in Table 1. This table lists the maximum allowable length in feet of the exhaust pipe that may be used for all furnace inputs as related to the number of elbows required and the termination. (See shaded area.)

Vertical through-the-roof installations do not require a vent termination. Use 2-in. PVC pipe extending a minimum of 12 inches above the anticipated level of snow accumulation. See exhaust pipe requirements, Figure 18. When 3-in. vent pipe is used from furnace to the roof, reduce it to 2 inches before penetrating the roof. A maximum of 18 inches of 2-in. pipe may be used below the roof. Maximum exposed vent length above the roof line is 30”.

Horizontal vent terminations require a 2-in. PVC tee positioned 12 inches from the outside wall. See exhaust pipe requirements, Figure 21. When 3-in. pipe is used from the furnace to the outside wall, reduce it to 2 inches before penetrating the wall. A maximum of 18 inches of 2-in. pipe may be used inside the wall.

An alternate termination may be used as shown in Figure 15 to clear anticipated snow levels. The tee may be raised up to 24 inches above the wall penetration. Use two medium-radius bend, 2-in. PVC elbows and a length of 2-in. PVC pipe so that the elbows are on 24-in. centers.

NON-DIRECT VENT TERMINATION LOCATION REQUIREMENTS

▲ CAUTION

MOISTURE IN THE COMBUSTION PRODUCTS CONDENSES AS IT LEAVES THE TERMINATION. THIS CONDENSATE CAN FREEZE ON EXTERIOR WALLS, UNDER THE EAVES, AND ON SURROUNDING OBJECTS. SOME DISCOLORATION IS TO BE EXPECTED. HOWEVER, IMPROPER LOCATION OR

INSTALLATION CAN CAUSE STRUCTURAL OR EXTERIOR FINISH DAMAGE TO THE BUILDING.

Non-direct venting location requirements are slightly different in some cases than direct venting. Install a non-direct vent with the following minimum clearances.

See Figure 16.

1. Locate the bottom of the vent terminal at least 12 inches above grade. Increase the 12-in. minimum to keep the terminal openings above the level of snow accumulation, where applicable.
2. The vent shall not terminate over public walkways or over an area where condensate or vapor could create a nuisance or hazard.
3. 4 feet below, 4 feet horizontally from, or 1 foot above any door, window soffit, under eave vent or gravity air inlet to the building.
4. The vent terminal shall have a minimum horizontal clearance of 4 feet from electric meters, gas meters, regulators and relief equipment.
5. 6 feet from an inside corner formed by two exterior walls – 10 feet is the recommended distance.
6. Locate it 3 feet above any forced air inlet located within 10 feet. Any fresh air or make-up air inlet, such as for a dryer or furnace area, is considered a forced air inlet.

7. Avoid areas where dripping condensate may cause problems, such as above planters, patios, or adjacent to windows where steam may cause fogging.

In addition to the minimum clearances listed above, the vent location should also be governed by the following guidelines.

1. Do not terminate under any kind of patio or deck. If running the vent under a deck, insulate it to insure no condensate freezes and blocks the pipe.
2. Do not locate on the side of a building with prevailing winter winds. This will help prevent moisture from freezing on walls and overhangs (under eaves).
3. Do not extend vent directly through brick or masonry surfaces. Use a rust-resistant sheet metal or plastic backing plate behind vent.
4. Do not locate too close to shrubs as condensate may stunt or kill them.
5. Minimum vertical clearances of 1 foot are recommended for overhangs up to 1 foot horizontal. The vertical clearance should be increased equally for each additional increase in horizontal overhang to a maximum vertical clearance of 6 feet.
6. Caulk all cracks, seams and joints within 6 feet horizontally and above and below vent.

FIGURE 16
OTHER THAN DIRECT VENT TERMINAL CLEARANCES

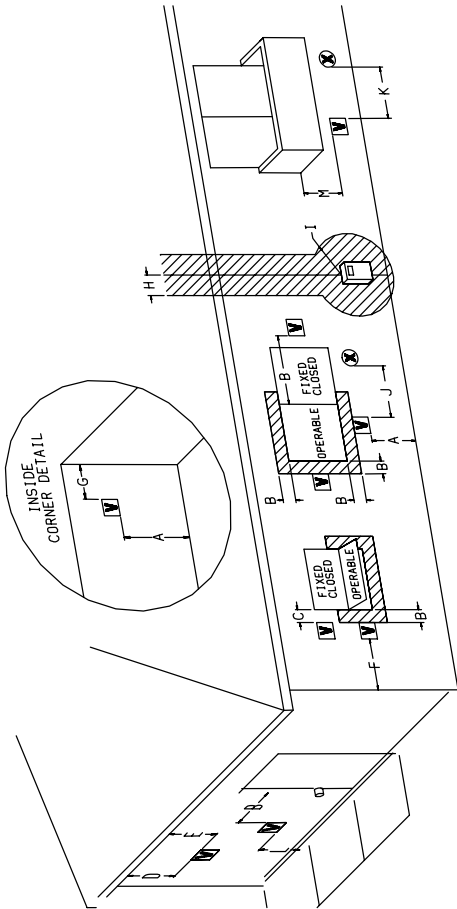

	Canadian Installations ¹	US Installations ²	Canadian Installations ¹	US Installations ²
A=	Clearance above grade, veranda, porch, deck, or balcony	12 inches (30 cm)	Clearance to nonmechanical air supply inlet to building or the combustion air inlet to any other appliance	4 feet (1.2 m) below or to side of opening; 1 foot (300 mm) above opening
B=	Clearance to window or door that may be opened	6 inches (15 cm) for appliances ≤10,000 BTUH (3 kW), 12 inches (30 cm) for appliances > 10,000 BTUH (3 kW) and ≤100,000 BTUH (30 kW), 36 inches (91 cm) for appliances >100,000 BTUH (30 kW)	6 inches (15 cm) for appliances ≤10,000 BTUH (3 kW), 12 inches (30 cm) for appliances > 10,000 BTUH (3 kW) and ≤100,000 BTUH (30 kW), 36 inches (91 cm) for appliances >100,000 BTUH (30 kW)	4 feet (1.2 m) below or to side of opening; 1 foot (300 mm) above opening
C=	Clearance to permanently closed window	*	Clearance to a mechanical air supply inlet	3 feet (91 cm) above if within 10 feet (3 m) horizontally
D=	Vertical clearance to ventilated soffit located above the terminal within a horizontal distance of 2 feet (61 cm) from the center line of the terminal	*	Clearance above paved sidewalk or paved driveway located on public property	7 feet (2.13 m) †
E=	Clearance to unventilated soffit	*	Clearance under veranda, porch, deck, or balcony	12 inches (30 cm) ‡
F=	Clearance to outside corner	*		*
G=	Clearance to inside corner	*		*
H=	Clearance to each side of center line extended above meter/regulator assembly	3 feet (91 cm) within a height 15 feet above the meter/regulator assembly		
I=	Clearance to service regulator vent outlet	3 feet (1.83 m)		

¹ In accordance with the current CSA B149.1 Natural Gas and Propane Installation Code
² In accordance with the current ANSI Z223.1 / NFPA 54 National Fuel Gas Code
 † A vent shall not terminate directly above a sidewalk or paved driveway that is located between two single family dwellings and serves both dwellings.
 ‡ Permitted only if veranda, porch, deck, or balcony is fully open on a minimum of two sides beneath the floor.
 * For clearances not specified in ANSI Z223.1 / NFPA 54 or CAN/CGA-B149, one of the following shall be indicated:
 a) A reference to the following footnote:
 "Clearance in accordance with local installation codes, the requirements of the gas supplier and the manufacturer's installation instructions."

DIRECT VENT INSTALLATIONS

▲ WARNING

READ AND FOLLOW ALL INSTRUCTIONS IN THIS SECTION. FAILURE TO PROPERLY VENT THIS FURNACE CAN CAUSE CARBON MONOXIDE POISONING OR AN EXPLOSION OR FIRE, RESULTING IN PROPERTY DAMAGE, PERSONAL INJURY OR DEATH.

Direct vent installations require a dedicated combustion air and venting system. All air for combustion is taken from the outside atmosphere and all combustion products are discharged to the outdoors. Therefore, no ventilation or combustion air openings are required.

IMPORTANT: *The plastic combustion air and venting components are of Schedule 40 PVC. If using ABS piping ensure that the solvent cement is compatible for joining PVC to ABS components or use a mechanical connection that can withstand the vent temperatures and are corrosion resistant.*

INSTALLATION GUIDELINES

All exhaust piping must be installed in compliance with Part 7, "Venting of Equipment," of the latest edition of the National Fuel Gas Code NPFA54/ANSI Z223.1-, local codes or ordinances and these instructions.

1. Vertical piping is preferred.
2. All horizontal piping must slope upward a minimum of 1/4 inch per foot of run so that condensate drains toward the furnace.
3. All horizontal runs must be supported at least every 4 feet. No sags or dips are permitted.
4. **IMPORTANT:** *Do not connect vent with any other appliance. Do not install in the same chase or chimney with a metal or high temperature plastic pipe from another gas or fuel-burning appliance unless the required minimum clearances to combustibles are maintained between the PVC pipe and other pipes.*

TABLE 2
FOR DIRECT VENT APPLICATIONS - AIR FOR COMBUSTION PROVIDED FROM OUTDOORS

MAXIMUM ALLOWABLE LENGTH IN FEET OF EACH EXHAUST PIPE AND INTAKE AIR PIPE

FURNACE INPUT	PIPE SIZE	TERMINATION	VENT TERMINATION KIT RECOMMENDED (RXGY-D0* Kits for Horizontal Venting Only)	NUMBER OF ELBOWS 45° or 90° Medium / Long Radius ONLY		
				1 - 2	3 - 4	5 - 6
45,000	2"	Standard/Concentric	RXGY-D02/RXGY-E03	65	60	55
		Alternate	RXGY-D02	55	50	45
60,000	2"	Standard/Concentric	RXGY-D02/RXGY-E03	40	35	30
		Alternate	RXGY-D02	30	25	20
	3"	Standard/Concentric	RXGY-D03/RXGY-E03	120	120	120
		Alternate	RXGY-D03	110	105	100
75,000	2"	Standard/Concentric	RXGY-D02/RXGY-E03	20	15	10
		Alternate	Not Recommended	NR	NR	NR
	3"	Standard/Concentric	RXGY-D03/RXGY-E03	120	120	120
		Alternate	RXGY-D03	100	95	85
90,000	3"	Standard/Concentric	RXGY-D03/RXGY-E03	110	105	95
		Alternate	RXGY-D03	50	40	35
105,000	3"	Standard/Concentric	RXGY-D03/RXGY-E03	110	105	95
		Alternate	RXGY-D03	50	40	35
120,000	3"	Standard/Concentric	RXGY-D03/RXGY-E03	45	35	30
		Alternate	RXGY-D03	45	35	30
		Alternate	RXGY-D04	105	95	90

NOTES:

- 1.N.R. - NOT RECOMMENDED.
- 2.MAXIMUM OF 6 ELBOWS MAY BE USED. DO NOT COUNT ELBOWS IN ALTERNATE TERMINATION KIT. MEDIUM OR LONG SWEEP ELBOWS MAY BE USED.
- 3.A 45 DEGREE ELBOW IS CONSIDERED ONE ELBOW.
- 4.CONCENTRIC TERMINATION NO. RXGY-E03 IS FOR THRU-THE-ROOF OR THRU-THE-WALL VENTING.
- 5.USE KITS RXGY-D02 (2") OR RXGY-D03 (3") FOR STANDARD OR ALTERNATE THRU-THE-WALL VENTING.
- 6.USE KITS RXGY-D04 FOR ALTERNATE VENTING OF 120,000 BTUH UNITS WITH LONG RUNS.

5. For horizontal runs where water may collect, wrap the vent pipe with self-regulating 3 or 5 watt heat tape. The heat tape must be U.L. listed and installed per the manufacturer's instructions.
6. The minimum vent pipe length is 5 feet.

Size the exhaust and combustion air intake pipes as specified in Table 2. This table lists the maximum allowable length in feet of the exhaust and combustion air intake pipes that may be used for all furnace inputs as related to the number of elbows required and the termination (see shaded area).

7. The maximum exposed vent length (above the roof line) is 30".

COMBUSTION AIR FOR DIRECT VENT INSTALLATIONS

THE COMBUSTION AIR SYSTEM DESIGNED FOR THIS FURNACE MUST BE USED.

When this furnace is installed as a direct vent forced air furnace, all combustion air is supplied directly to the burner through a special air inlet system outlined in these instructions. This system consists of field-supplied Schedule 40 or 26 SDR-PVC pipe and one of the following horizontal vent termination kits: RXGY-D02, RXGY-D03, RXGY-D04, or RXGY-E03.

NOTE: Schedule 40 ABS-DWV pipe and fittings may be used as an alternate to PVC pipe for the combustion air inlet and vent pipes.

The combustion air for this furnace is supplied directly from the outdoors through the combustion air inlet system.

When the furnace is installed in the same space with other gas appliances, such as a water heater, be sure there is an adequate supply of combustion and ventilation air for the other appliances. Do not delete or reduce the combustion air supply required by the other gas appliances in this space. See Z223.1, National Fuel Gas Code (NFPA54) for determining the combustion air requirements for gas appliances. An unconfined space must have at least 50 cubic feet (volume) for each 1,000 BTUH of the total input of all appliances in the space. If the open space containing the appliances is in a building with tight construction (contemporary construction), outside air may still be required for the appliances to burn and vent properly. Outside air openings should be sized the same as for a confined space.

STANDARD TERMINATIONS

STANDARD VERTICAL TERMINATIONS

COMBUSTION AIR PIPING

Use two medium-radius sweep elbows to keep the inlet downward to prevent entry of rain. See Figure 19 for the proper relationship of combustion air to exhaust termination.

STANDARD HORIZONTAL TERMINATIONS

COMBUSTION AIR PIPING

When 3-in. pipe is used between the furnace and outside wall, reduce it to 2 inches before penetrating the wall. Up to 18 inches of 2-in. pipe may be used inside the wall.

The standard horizontal intake air termination for all models is a 2-in. PVC coupling with a wind deflector vane (provided) attached. Cut a 2¼-in. length of 2-in. PVC pipe. Connect this pipe and another 2-in. PVC coupling to the coupling at the wall. The outer coupling must terminate 4 inches from the wall. See Figure 20, Detail B, for vane location. Attach vane in vertical position with PVC solvent.

IMPORTANT: To ensure proper furnace operation, the supplied vane must be installed in the vertical position as shown in Figure 20, Detail B.

The combustion air inlet terminal must be located with respect to the exhaust terminal as shown in Figure 20, Detail C.

IMPORTANT: All furnaces with horizontal air intakes, except those using concentric vent kit RXGY-E03, must have a drain tee assembly and trap installed as close to the furnace as possible. This is to drain any water that may be in the combustion air pipe to prevent it from entering the furnace combustion chamber.

These parts are included in kits RXGY-D02 (for 2-in. pipe), RXGY-D03 (for 3-in. pipe) and RXGY-D04 (special for the 120,000 BTU furnace installed with the alternate horizontal termination). Attach the trap to the bottom of the tee with PVC solvent. Connect the other end to a suitable drain, as to the downstream of a condensate trap on the furnace.

STANDARD VERTICAL TERMINATIONS

EXHAUST VENT PIPING

Vertical through-the-roof vent applications do not require an exhaust terminal. The exhaust vent must terminate at least 12 inches above the combustion intake air termination. The exhaust vent for models with inputs of 90,000 through 120,000 BTUH is 2-in. PVC pipe 120,000 BTUH models with excessively long runs require 2½".

Refer to Table 2 for proper application. This must be reduced to 1" or 1½" the last 12 inches for models with inputs of 45,000 through 75,000 BTUH. See Figure 23.

STANDARD HORIZONTAL TERMINATIONS

EXHAUST PIPING

For direct vent systems the standard termination is 2-in. PVC pipe extending 12 inches from the wall for furnaces with inputs from 105,000 to 120,000 BTUH. Install a 2-in. coupling at the outside wall to prevent the termination from being pushed inward. When 3-in. pipe is used between the furnace and outside wall, reduce to 2 inches before penetrating the wall. The standard termination is 1½ -in. PVC pipe extending outward 12 inches from the wall for models with inputs of 45,000 to 75,000 BTUH. Install a 2-in. to 1½-in. coupling at the outside wall to prevent pushing the termination back into the wall. See Figure 20, Detail B.

The combustion air and exhaust terminations must be at least 12 inches above grade and must be oriented with respect to each other as shown in Figure 20. Refer to section on alternate venting options when higher snow levels are anticipated.

ALTERNATE TERMINATIONS

ALTERNATE HORIZONTAL DIRECT VENT TERMINATIONS

KIT NOS. RXGY-D02, -D03 AND -D04

The combustion air and exhaust terminations may be raised a maximum of 60 inches above the wall penetration to maintain the required 12 inch clearance above grade or snow level. See Figure 17. Size the pipe length according to Table 2.

IMPORTANT: The following guidelines must be met when extending beyond 24 inches of pipe on the exterior of the structure:

- Size the entire vent system according to the alternate, not standard, termination shown in Table 2.

- Insulate the entire length of vent pipe, between the elbow where the pipe exits the wall and the elbow where the termination is made, with a closed-cell insulation, such as “Arm-a-Flex” or “Rub-a-TEX” with a minimum of 1/2” thickness.
- All elbows installed on the exterior of the building must be of the long sweep nature.
- As required for the horizontal piping ran within the structure, any pipe ran horizontal outside the structure must slope upward a minimum of 1/4” per foot run so that condensate drains toward the furnace.

From the top elbow in the exhaust pipe, extend a length of PVC pipe outward so that it terminates exactly 12 inches from the wall. See Figure 17. Reduce the termination pipe extension to is 1 1/2 inch pipe for 45,000 BTUH through 75,000 BTUH units.

The 45,000 BTUH unit only uses kit RXGY-D02. The 60,000 BTUH and 75,000 BTUH units may use kits RXGY-D02 or RXGY-D03 depending on pipe lengths and number of elbows. Use kit RXGY-D03 with 90,000 BTUH through 120,000 BTUH units. **The RXGY-D04 kit only applies to the 120,000 BTUH unit using an alternate termination and long runs.** See Table 2.

The following are parts lists for the RXGY-D02, RXGY-D03 and RXGY-D04 alternate horizontal direct vent termination kits:

RXGY-D02

1. 2-in. tee with reducer assembly
2. 1/2-in. PVC 6-in. dia. trap
3. PVC vane
4. 2-in. PVC elbow
5. 1 1/2-in. PVC nipple with coupling
6. PVC strap
7. vent template

FIGURE 17
ALTERNATE HORIZONTAL DIRECT VENT TERMINATION

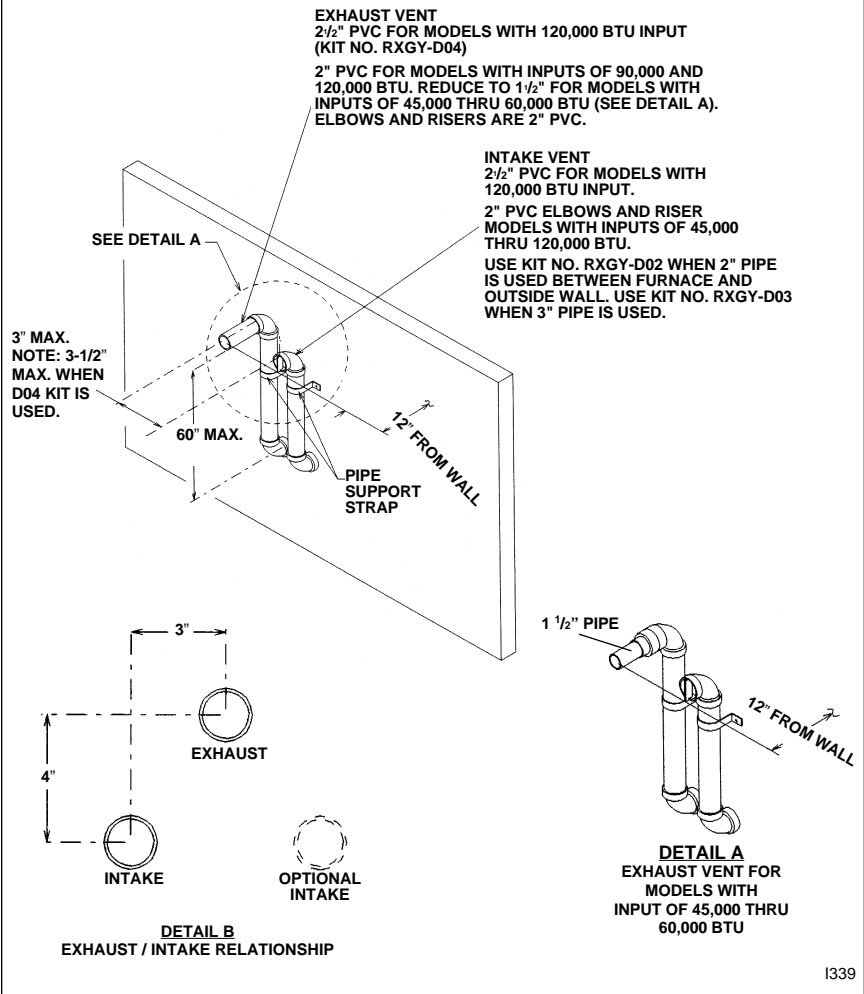

RXGY-D03

1. 3-in. tee with reducer assembly
2. 1/2-in. PVC 6-in. dia. trap
3. PVC vane
4. 2-in. PVC elbow
5. PVC strap
6. vent template

RXGY-D04

1. 2 1/2-in. PVC elbow
2. 3" x 2 1/2" PVC bushing
3. 2 1/2" x 6 1/2" long PVC pipe
4. 2 1/2" x 16" long PVC pipe
5. 2 1/2" x 21" long PVC pipe
6. PVC vane
7. 3-in. tee with reducer assembly
8. 6-in. dia. 1/2-in. PVC trap
9. PVC strap
10. vent template

NOTE: The RXGY-D04 kit only applies to the 120,000 BTUH unit using an alternate termination and excessively long runs.

1339

CONCENTRIC TERMINATIONS

VERTICAL/HORIZONTAL CONCENTRIC VENT KIT NO. RXGY-E03

This kit is for vertical/horizontal intake air/vent runs and may be installed through roofs and sidewalls. One 5" diameter hole is required for the installation. See Figure 18 for the general layout. Complete installation instructions are included with the kit.

FIGURE 18
CONCENTRIC VENT KIT NO. RXGY-E03

SIDEWALL ASSEMBLY

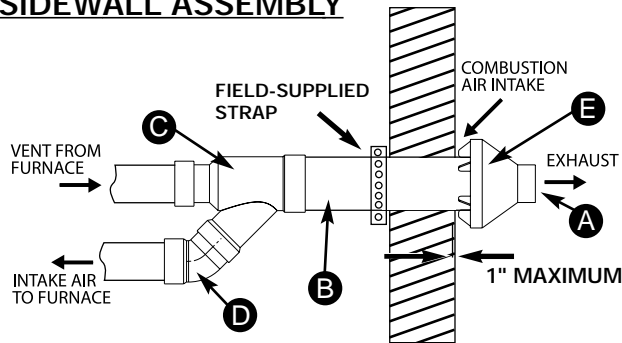

ITEM No. DESCRIPTION

A	2.5" PVC PIPE SCHEDULE 40 -- 37.125" LONG
B	4" PVC PIPE SCHEDULE 40 -- 24" LONG
C	3" x 3" x 4" SPECIAL CONCENTRIC FITTING
D	3" x 45° STREET ELBOW (FIELD SUPPLIED)
E	PVC RAINCAP

ROOF INSTALLATION

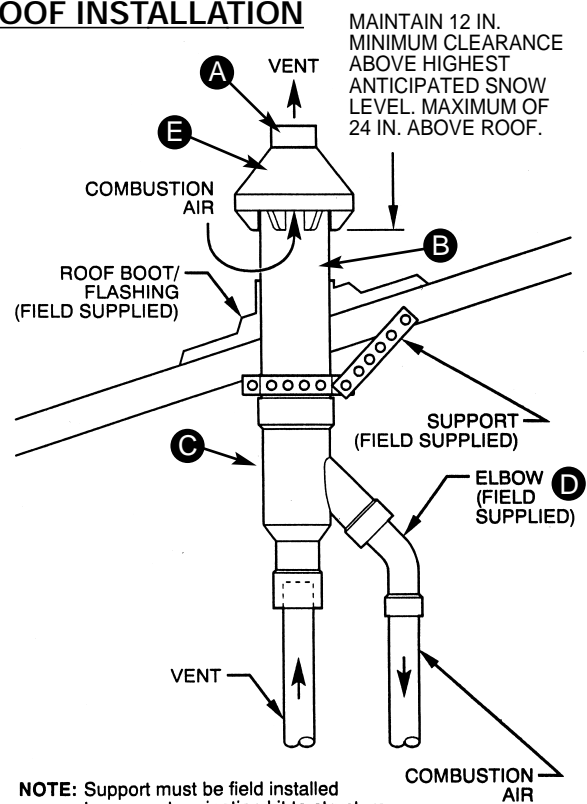

FIGURE 19
STANDARD VERTICAL DIRECT VENTING
 UPFLOW MODEL SHOWN (TYPICAL FOR DOWNFLOW MODELS)

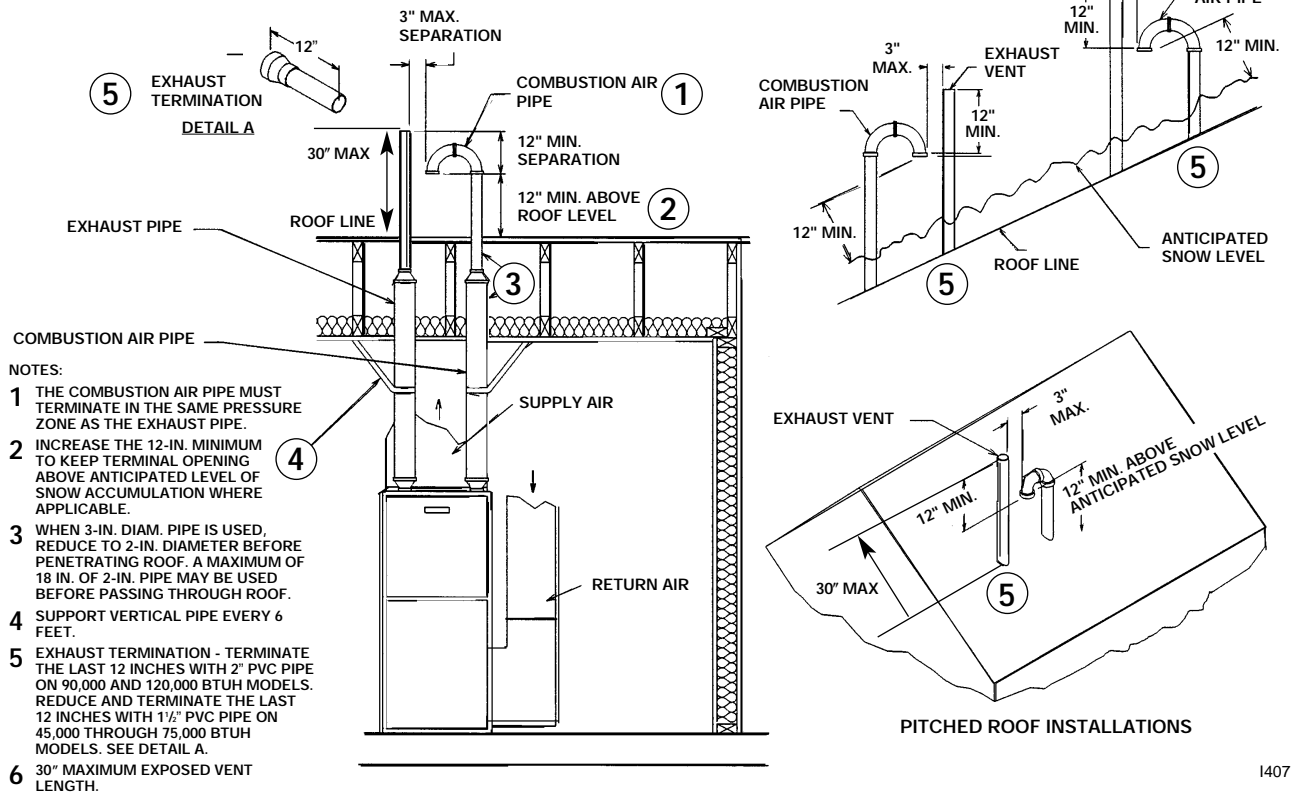

FIGURE 20
STANDARD HORIZONTAL DIRECT VENTING
 UPFLOW MODEL SHOWN (TYPICAL FOR DOWNFLOW MODELS)

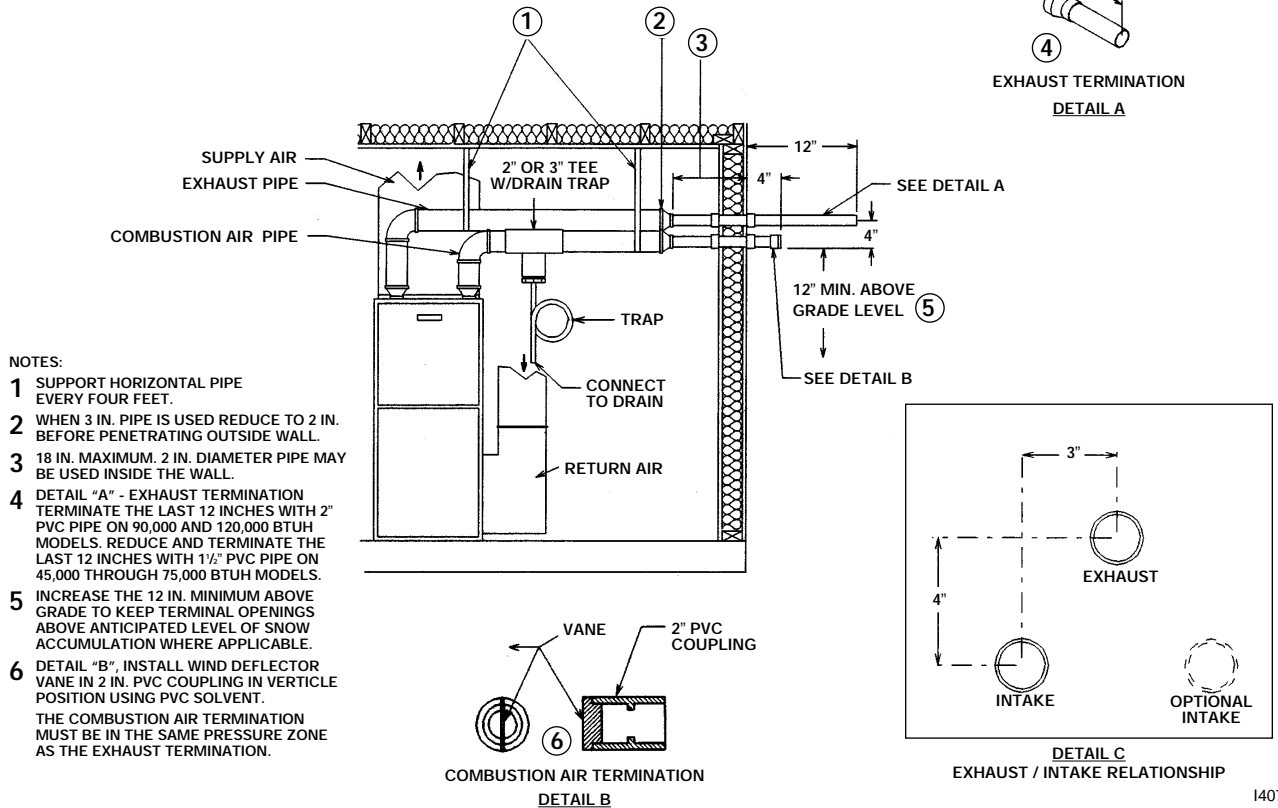
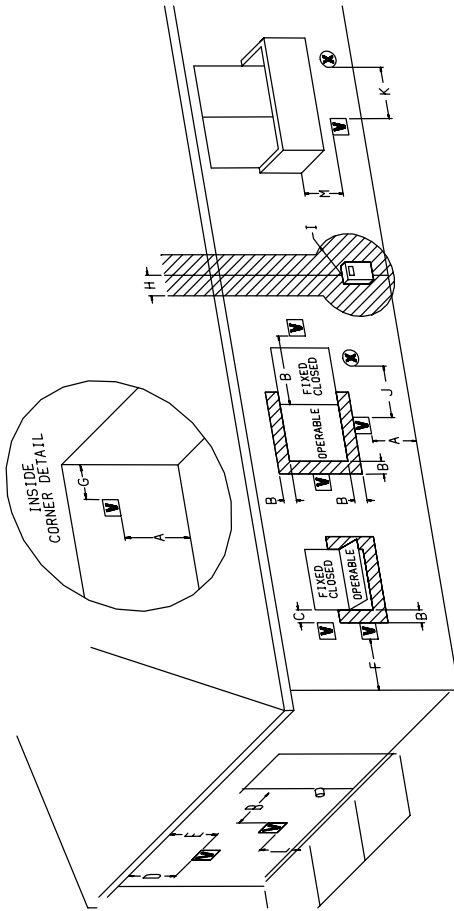

FIGURE 21
DIRECT VENT TERMINAL CLEARANCES



	Canadian Installations ¹	US Installations ²	Canadian Installations ¹	US Installations ²
A=	Clearance above grade, veranda, porch, deck, or balcony	12 inches (30 cm)	Clearance to nonmechanical air supply inlet to building or the combustion air inlet to any other appliance	6 inches (15 cm) for appliances ≤10,000 BTUH (3 kW), 9 inches (23 cm) for appliances >10,000 BTUH (3 kW) and ≤50,000 BTUH (15 kW), 12 inches (30 cm) for appliances >50,000 BTUH (15 kW)
B=	Clearance to window or door that may be opened	6 inches (15 cm) for appliances ≤10,000 BTUH (3 kW), 9 inches (23 cm) for appliances >10,000 BTUH (3 kW) and ≤50,000 BTUH (15 kW), 36 inches (91 cm) for appliances >50,000 BTUH (15 kW)	Clearance to a mechanical air supply inlet	6 inches (15 cm) for appliances ≤10,000 BTUH (3 kW), 12 inches (30 cm) for appliances >10,000 BTUH (3 kW) and ≤50,000 BTUH (15 kW), 36 inches (91 cm) for appliances >50,000 BTUH (15 kW)
C=	Clearance to permanently closed window	*	Clearance above paved sidewalk or paved driveway located on public property	3 feet (91 cm) above if within 10 feet (3 m) horizontally
D=	Vertical clearance to ventilated soffit located above the terminal within a horizontal distance of 2 feet (61 cm) from the center line of the terminal	*	Clearance under veranda, porch, deck, or balcony	*
E=	Clearance to unventilated soffit	*		
F=	Clearance to outside corner	*		
G=	Clearance to inside corner	*		
H=	Clearance to each side of center line extended above meter/regulator assembly	3 feet (91 cm) within a height 15 feet above the meter/regulator assembly		
I=	Clearance to service regulator vent outlet	3 feet (1.83 m)		

¹ In accordance with the current CSA B149.1 Natural Gas and Propane Installation Code
² In accordance with the current ANSI Z223.1 / NFPA 54 National Fuel Gas Code
† A vent shall not terminate directly above a sidewalk or paved driveway that is located between two single family dwellings and serves both dwellings.
‡ Permitted only if veranda, porch, deck, or balcony is fully open on a minimum of two sides beneath the floor.
* For clearances not specified in ANSI Z223.1 / NFPA 54 or CAN/CGA-B149, one of the following shall be indicated:
a) A reference to the following footnote:
"Clearance in accordance with local installation codes, the requirements of the gas supplier and the manufacturer's installation instructions."

LOCATION REQUIREMENTS HORIZONTAL DIRECT VENTS

▲ CAUTION

THE COMBUSTION PRODUCTS AND MOISTURE IN THE FLUE GASES WILL CONDENSE AS THEY LEAVE THE TERMINATION. THE CONDENSATE CAN FREEZE ON THE EXTERIOR WALL, UNDER THE EAVES AND ON SURROUNDING OBJECTS. SOME DISCOLORATION TO THE EXTERIOR OF THE BUILDING IS TO BE EXPECTED. HOWEVER, IMPROPER LOCATION OR INSTALLATION CAN RESULT IN STRUCTURAL OR EXTERIOR FINISH DAMAGE TO THE BUILDING AND MAY RECIRCULATE PRODUCTS OF COMBUSTION INTO THE COMBUSTION AIR TERMINAL AND FREEZE.

The vent must be installed with the following minimum clearances. See Figures 21 & 22.

1. The bottom of the vent terminal and the air inlet shall be located at least 12 inches above grade. Increase the 12-in. minimum to keep the terminal openings above the level of snow accumulation, where applicable.
2. The vent shall not terminate over public walkways or over an area where condensate or vapor could create a nuisance or hazard.
3. The vent terminal shall be located at least one foot from any opening through which flue gases could enter a building.
4. The vent terminal shall be at least 3 feet above any forced air inlet located within 10 feet, except the combustion air inlet of a direct vent appliance.
5. The vent terminal shall have a minimum horizontal clearance of 4 feet from electric meters, gas meters, regulators and relief equipment.
6. Locate the furnace combustion air inlet minimum of 3 feet from the vent of any other gas or fuel burning appliance or clothes dryer to prevent recirculation of the flue gases into the furnace combustion air inlet. The only exception to this requirement is the case of multiventing two or more furnaces, which is covered in the section on multiventing in these instructions.

In addition to the minimum clearances listed above, the vent location should also be governed by the following guidelines.

1. Do not terminate under any kind of patio or deck. If running the vent under a deck, insulate it to insure no condensate freezes and blocks the pipe.
2. Do not terminate behind any area that may allow the flue products to become stagnant and recirculate.
3. Do not locate on the side of a building with prevailing winter winds. This will help prevent moisture from freezing on walls and overhangs (under eaves).
4. Do not extend vent directly through brick or masonry
5. Do not locate too close to shrubs as condensate may stunt or kill them.
6. Minimum vertical clearances of 1 foot are recommended for overhangs up to 1 foot horizontal. The vertical clearance should be increased equally for each additional increase in horizontal overhang to a maximum vertical clearance of 6 feet.
7. Caulk all cracks, seams and joints within 6 feet horizontally and above and below vent. See Figure 22.

FIGURE 22
MOISTURE ZONES

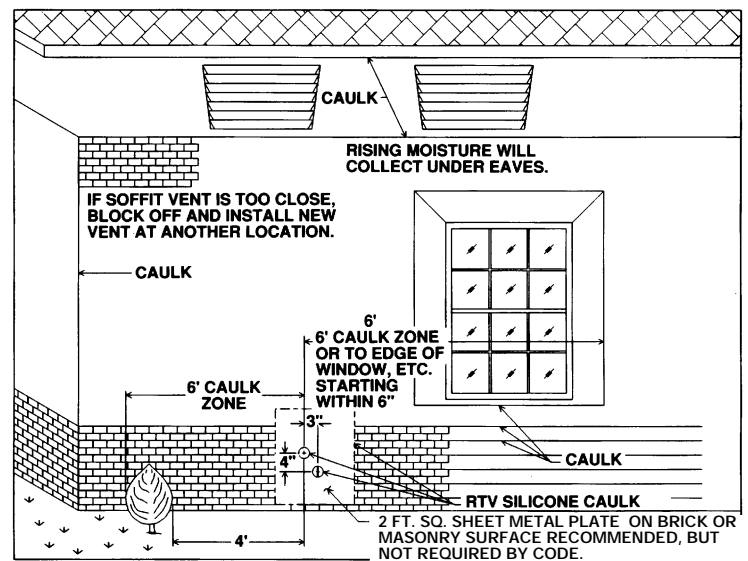

FIGURE 23
TWO FURNACE VENTING THROUGH ROOF

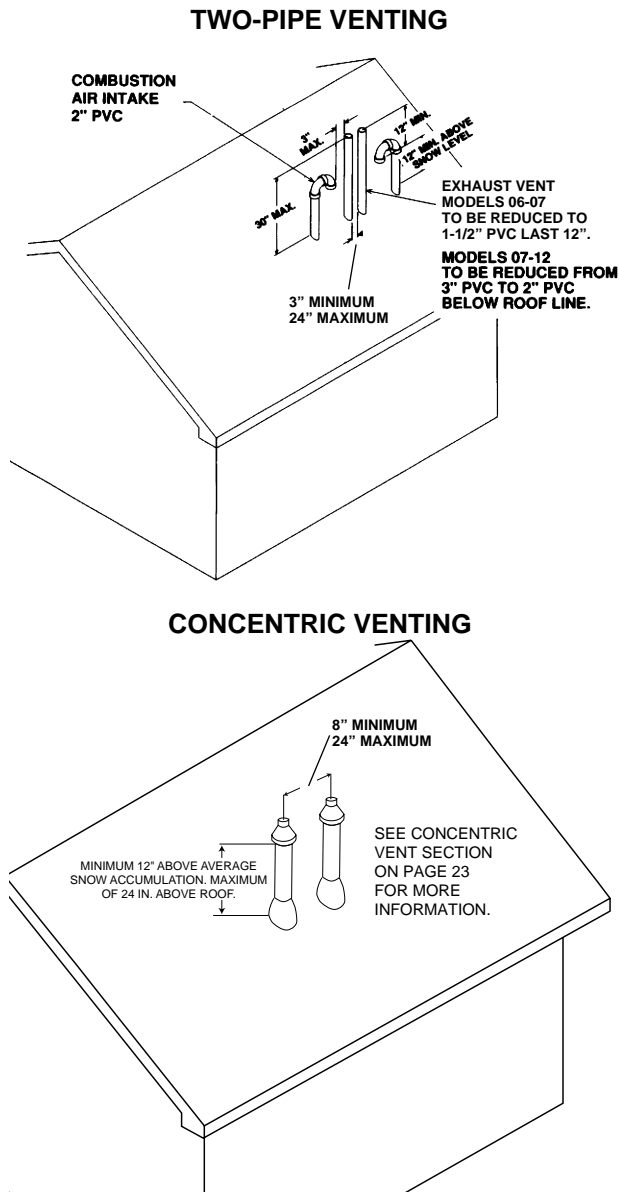
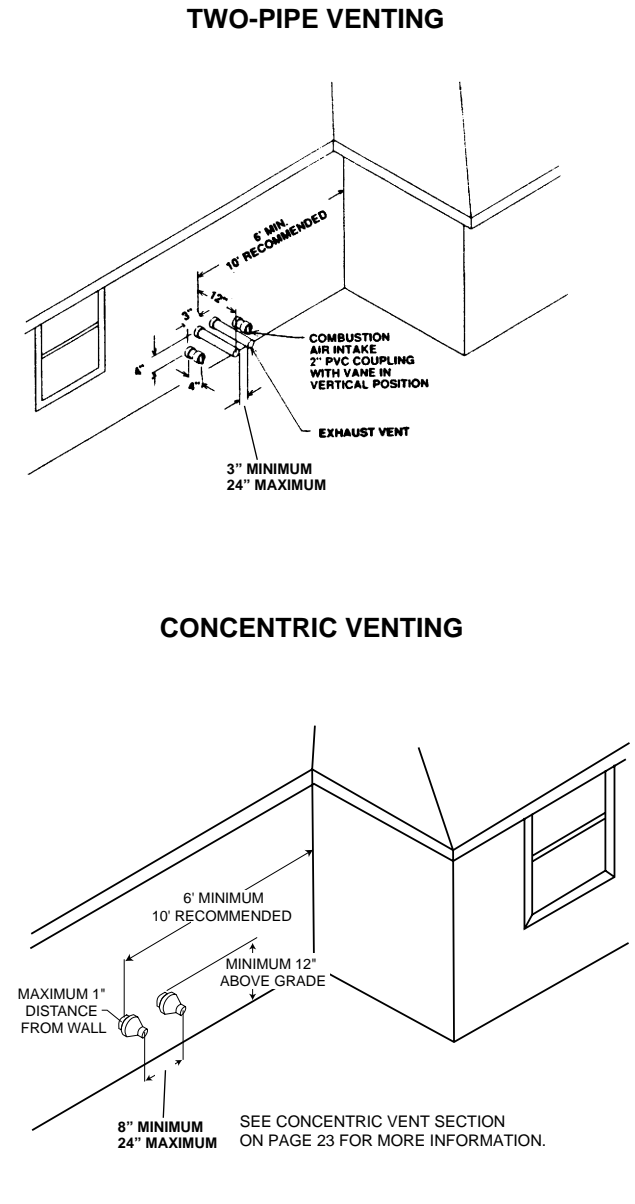

FIGURE 24
TWO FURNACE VENTING THROUGH WALL



8. Painted surfaces must be sound and in good condition with no cracking, peeling, etc. Painted surfaces will require maintenance.
9. Do not expose 3" x 2" reducer/bushing to outdoor ambient temperatures.

MULTIVENTING

IF VENTING TWO OR MORE FURNACES NEAR EACH OTHER IS REQUIRED, EACH FURNACE MUST BE INDIVIDUALLY VENTED - NO COMMON VENTING IS PERMITTED. See Figures 23 and 24 for positioning of the terminations. When more than two furnaces are to be vented, there must be at least 4 feet between the first two furnaces and the third, etc.

CONNECTING TO FURNACE

IMPORTANT: Clean and deburr all pipe cuts. The shavings must not be allowed to block the exhaust, inlet or condensate drain pipes.

UPFLOW FURNACE

The exhaust pipe connection is a 2-in. female PVC pipe fitting extending through the left side of the furnace top plate. This opening has a protective cap which should be removed just prior to installing the exhaust pipe. When 2-in. pipe is used, connect it directly to this fitting. When 3-in. pipe is used, connect a 2 to 3-in. coupling to this fitting with a short piece of 2-in. PVC pipe.

The inlet combustion air connection is at the right side of the top plate. An alternate combustion inlet air connection may be made on the right side of the jacket. This opening has a plastic cap. A combustion inlet air connection fitting is supplied with the furnace and it must be installed in the furnace by screwing it into the opening. Make sure the rubber "O-ring" supplied with the furnace is used with this fitting. See Figure 25.

DOWNFLOW/HORIZONTAL FURNACE

The exhaust pipe connection is a 2-in. upflow only PVC pipe fitting extending through the right side of the furnace top cover. This opening has a protective cap which should be removed just prior to installing the exhaust pipe. When 2-in. pipe is used, connect it directly to this fitting. When 3-in. pipe is used, connect with a 2- to 3-in. coupling directly to the 2-in. pipe.

The combustion inlet air connection is a 2-in. extruded hole on the left side of the top plate. When a 2-in. pipe is used, attach a 2-in. PVC coupling over this hole with RTV sealant and also add two sheet metal screws through the coupling into the extrusion to secure it in place, and add the required piping. When 3-in. pipe is required, use a 2- to 3-in. coupling and add the required piping. See Figure 26.

FIGURE 25
UPFLOW COMBUSTION AIR AND VENT PIPE CONNECTION

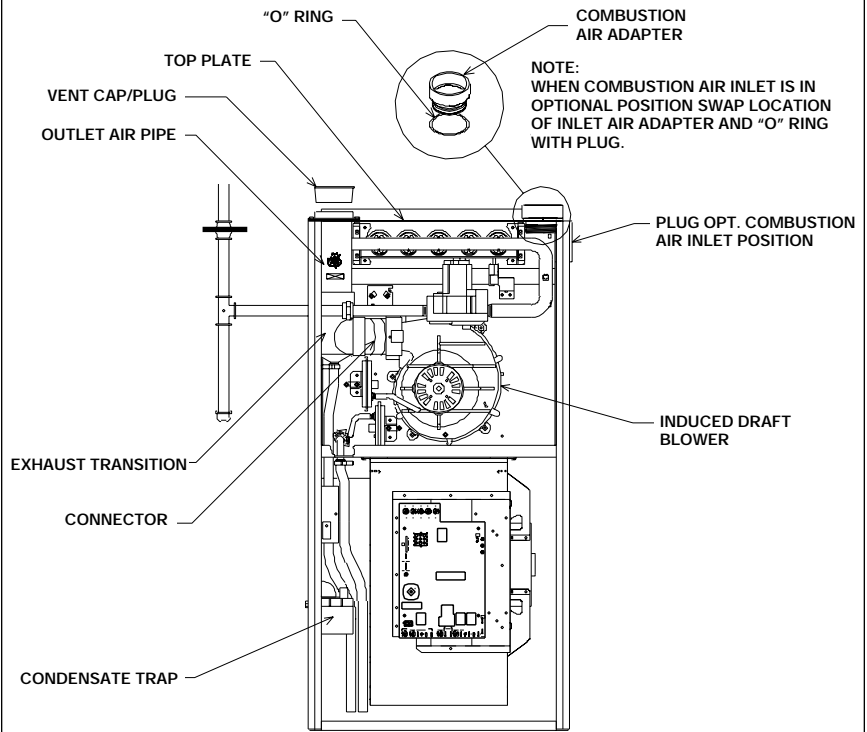

1329

FIGURE 26
DOWNFLOW/HORIZONTAL COMBUSTION AIR AND VENT PIPE CONNECTION

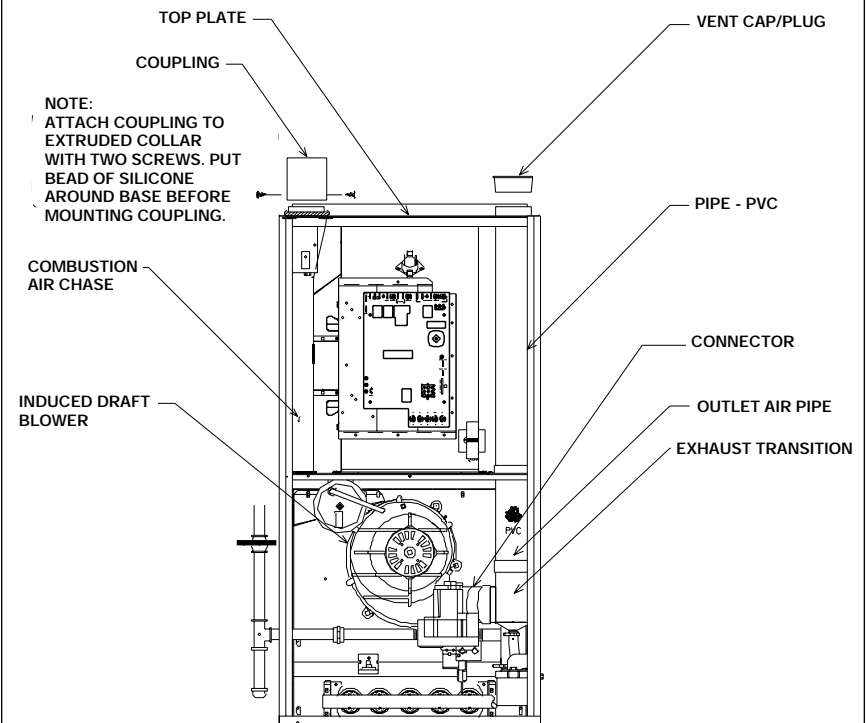

1329

CONDENSATE DRAIN/NEUTRALIZER

GENERAL INFORMATION

▲ CAUTION

DO NOT RUN DRAIN OUTDOORS. FREEZING OF CONDENSATE CAN CAUSE PROPERTY DAMAGE.

Important: Do not connect into a common drain line with an air conditioner evaporator coil drain located below the furnace. A blocked or restricted drain line can result in overflow of the coil pan and negate the furnace blocked drain shutoff control.

FILL TRAP ASSEMBLY WITH WATER BEFORE OPERATING THE FURNACE. This can be done by removing the drain hose from the trap and pouring about a cup of water into the vent trap. Water will flow into the house drain when the trap is full.

If local codes require, install a condensate neutralizer cartridge in the drain line. Install cartridge in horizontal position only. Also install an overflow line if routing to a floor drain. See Figures 27 and 28.

If no floor drain is available, install a condensate pump that is resistant to acidic water. Pumps are available from your local distributor. If pump used is not resistant to acidic water, a condensate neutralizer must be used ahead of the pump. The condensate pump must have an auxiliary safety switch to prevent operation of the furnace and resulting overflow of condensate in the event of pump failure. The safety switch must be wired through the "R" circuit only (low voltage) to provide operation in either heating or cooling modes.

UPFLOW MODELS

The condensate drain trap is located in the blower compartment on the left-hand side of the jacket. A short piece of 1/2-in. PVC pipe and a 1/2-in. tee are provided. Connect the 1/2-in. pipe to the elbow on the trap and the tee to this pipe so that the open end is upward. Run a drain tube from the bottom of the tee to a floor drain or condensate pump.

IMPORTANT: If installing the unit over a finished ceiling or living area, be certain to install an auxiliary condensate drain pan under the entire unit extending out under the condensate tee.

IMPORTANT: There are two options when choosing a height for the condensate riser:

CONDENSATE OVERFLOW: With a 5 1/2 inch riser installed above the tee, a blocked drain will result in overflow from the riser.

FURNACE SHUTDOWN: To cause the furnace to shut down when a blocked

drain is present, install a riser which is a minimum of 10 13/16". If the furnace is installed in an attic, crawlspace or other area where freezing temperatures may occur, the furnace drain can freeze while shut off for long periods of time.

Use a solvent cement that is compatible with PVC material. Cut the drain hoses to the appropriate length and connect to the trap with hose clamps. Tighten the clamps with pliers and check for leaks after attaching.

DOWNFLOW MODELS

IMPORTANT: There are two options when choosing a height for the condensate riser:

CONDENSATE OVERFLOW: With a 1 3/4 inch riser installed above the tee, a blocked drain will result in overflow from the riser.

FURNACE SHUTDOWN: To cause the furnace to shut down when a blocked drain is present, install a riser which is a minimum of 5 1/2". If the furnace is installed in an attic, crawlspace or other area where freezing temperatures may occur, the furnace drain can freeze while shut off for long periods of time.

Use a solvent cement that is compatible with PVC material.

FIGURE 27
UPFLOW CONDENSATE DRAIN

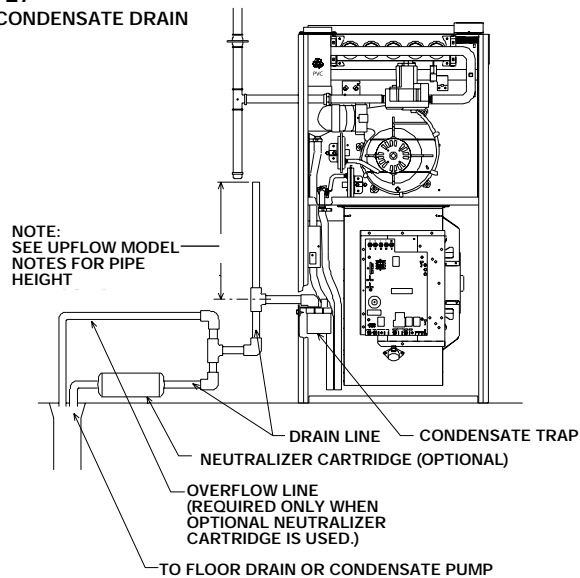

1408

FIGURE 28
DOWNFLOW CONDENSATE DRAIN

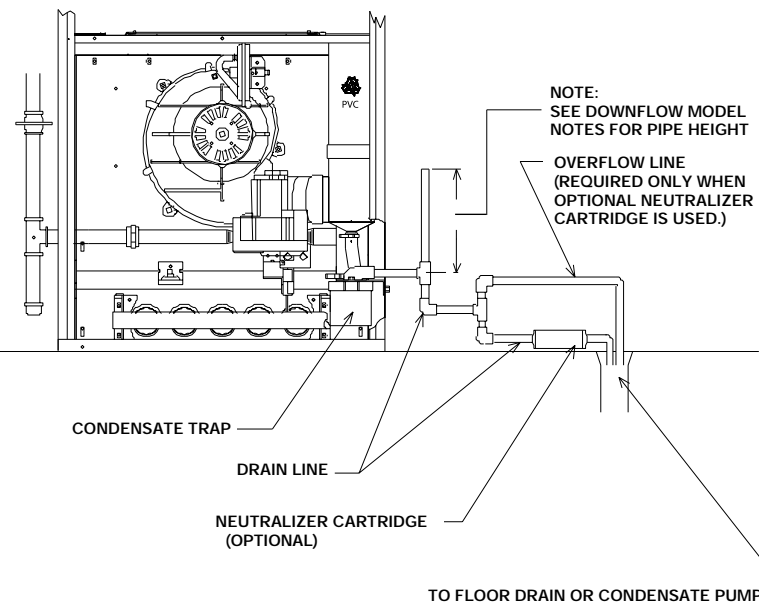

1408

REVERSING THE TRAP

UPFLOW UNITS

The trap may be moved to the right side for right side drainage. Open the knockout for the drain on the right side of the cabinet. Remove the bracket holding the trap from the left side. Seal the left side drain hole with a plug provided in the cloth bag with the furnace. Position the mounting bracket and trap so that the drain elbow is centered in the hole on the right. See Figure 29.

Drill two holes in the cabinet to mount the bracket. Mount the trap and bracket to the right side with the drain elbow pointing through the knockout. Connect the 1/2-in. pipe and tee as noted above. Route the drain hoses behind the control box, cut to the appropriate length, and connect to the trap with hose clamps.

IMPORTANT: DO NOT ALLOW ANY SAGS OR KINKS IN THE HOSES. This prevents proper condensate flow.

IMPORTANT: Do not connect into a common drain line with an air conditioner evaporator coil drain located above the furnace. A blocked or restricted drain line can result in overflow of the coil pan and negate the furnace blocked drain shutoff control.

DOWNFLOW UNITS

To convert to left side drainage, first remove the drainage hoses from the trap. Remove the trap from its mounting bracket, rotate it 180°, and mount in place with the drainage elbow pointing to the left. Reattach the drain hoses. Remove the plastic drainage knockout from the left side. See Figure 30.

IMPORTANT: When changing to the left side, interchange the rubber bushing on the right side with the hole plug on the left side. The hole plug must be in place to assure that the control compartment is sealed.

A length of 1/2-in. PVC pipe is provided for left hand drainage. Glue one end of the pipe to the elbow in the trap. Cut the pipe so that it extends through the left cabinet side one inch. Connect the 1/2-in. tee to the pipe with a riser and drain tube as listed above. Use the plastic plug from the left side drainage knockout to seal the right side drainage knockout.

IMPORTANT: Do not connect into a common drain line with an air conditioner evaporator coil drain located above the furnace. A blocked or restricted drain line can result in overflow of the coil pan and negate the furnace blocked drain shutoff control.

FILLING THE TRAP

FILL THE TRAP ASSEMBLY WITH WATER BEFORE OPERATING THE FURNACE. Do this by removing the drain hose from the trap or from the connection to the secondary coil. Pour about a cup of water into the vent trap. Any excess water flows into the house drain when the trap is full.

FIGURE 29
UPFLOW OPPOSITE SIDE CONDENSATE TRAP CONNECTION

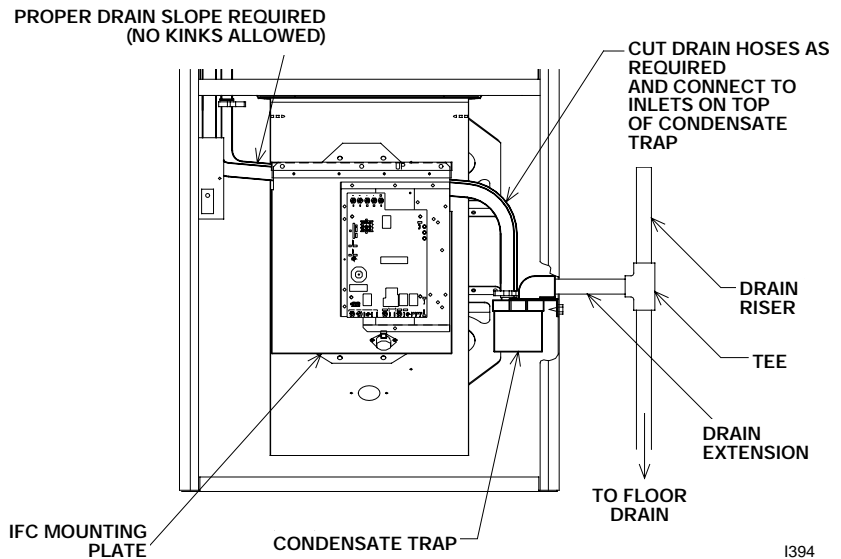
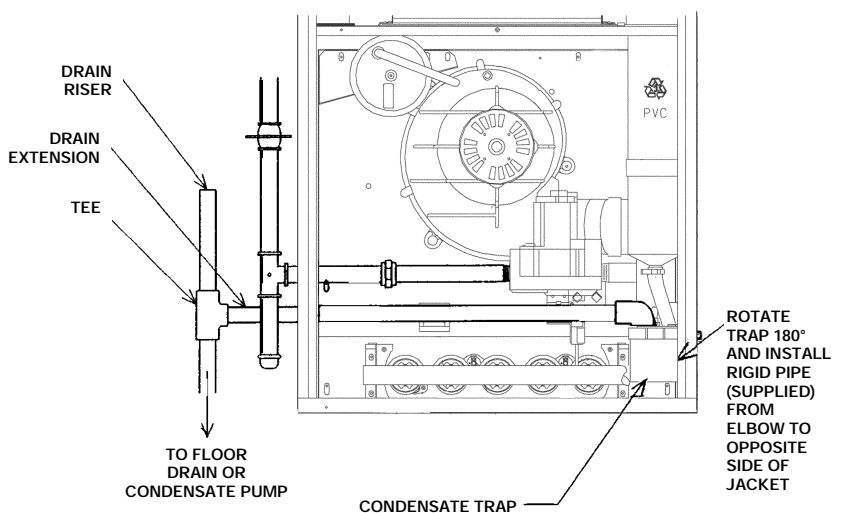

FIGURE 30
DOWNFLOW OPPOSITE SIDE CONDENSATE TRAP CONNECTION



CONDENSATE DRAIN FOR HORIZONTAL INSTALLATION

Refer to Figure 32 for Steps 1-5.

1. This unit is shipped factory ready for downflow installation. The condensate trap assembly and drain hoses require conversion for horizontal installation. Remove the existing condensate trap with the unit in the upright position.
2. Remove the burner compartment door from the unit.
3. Remove the two screws from the right side of the furnace jacket which support the trap mounting bracket ②. Remove the two plastic plugs on either side of the trap outlet hole and discard.
4. Remove the (L-shaped) clear vinyl drain tube ③ from the top of the existing trap ①.
Do not disconnect the short end from the furnace collector box.
5. Remove the ribbed drain tube ④ from the existing trap ① and the exhaust transition ⑤. Discard this tube. Retain the clamps for future use. Additional clamps are provided in the parts bag if any clamps are damaged during conversion process.

NOTE: The following steps should take place with the furnace in the horizontal position.

Refer to Figure 33 for Steps 6-11.

6. Locate the parts bag in the burner compartment. Install two plastic plugs ⑥ in the side of the jacket from bottom side up.
7. Fill the trap assembly ⑦ with 1/2 cup of water.

8. Attach the gasket ⑧ onto the trap assembly so that the gasket holes on the gasket line up with the holes on the trap assembly.
9. Insert the trap assembly with gasket up through the existing hole in the jacket and secure from inside the jacket. Use two screws provided. Screw down into the two "ears" molded into either side of the trap. Snug the trap assembly against the furnace jacket compressing the gasket slightly to eliminate any air leaks. **Do not** overtighten!
10. Attach the black molded rubber 90° elbow ⑨ to the straight spout on the trap top using a black nylon clamp ⑩. Attach the other end of the rubber elbow to the spout ⑪ located on the exhaust transition ⑤ using a black nylon clamp.
11. Attach the end of the ribbed tube ③ to the 45° elbow molded into the top of the trap assembly using a black nylon clamp.
IMPORTANT: Tighten all clamp connections with a pair of pliers and check for leaks after conversion is complete.
12. **IMPORTANT:** There are two options when choosing a height for the condensate riser:

CONDENSATE OVERFLOW:
With a 1¾ inch riser installed above the tee, a blocked drain will result in overflow from the riser.

FURNACE SHUTDOWN: To cause the furnace to shut down when a blocked drain is present, install a riser which is a minimum of 5½". If the furnace is installed in an attic, crawlspace or other area where freezing temperatures may occur, the furnace drain can freeze while shut off for long periods of time.

Use a solvent cement that is compatible with PVC material.

FIGURE 31
DOWNFLOW CONDENSATE DRAIN

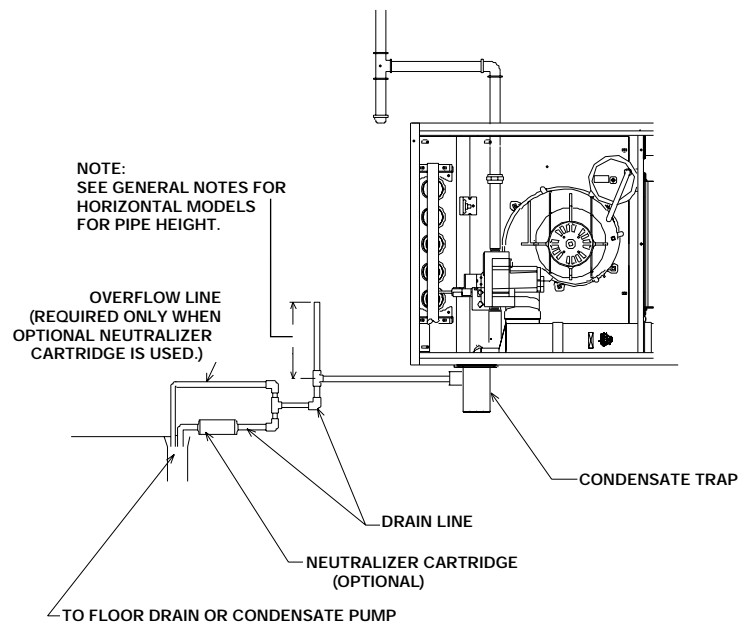

1408

CONDENSATE TRAP CONVERSION FROM DOWNFLOW TO HORIZONTAL INSTALLATION

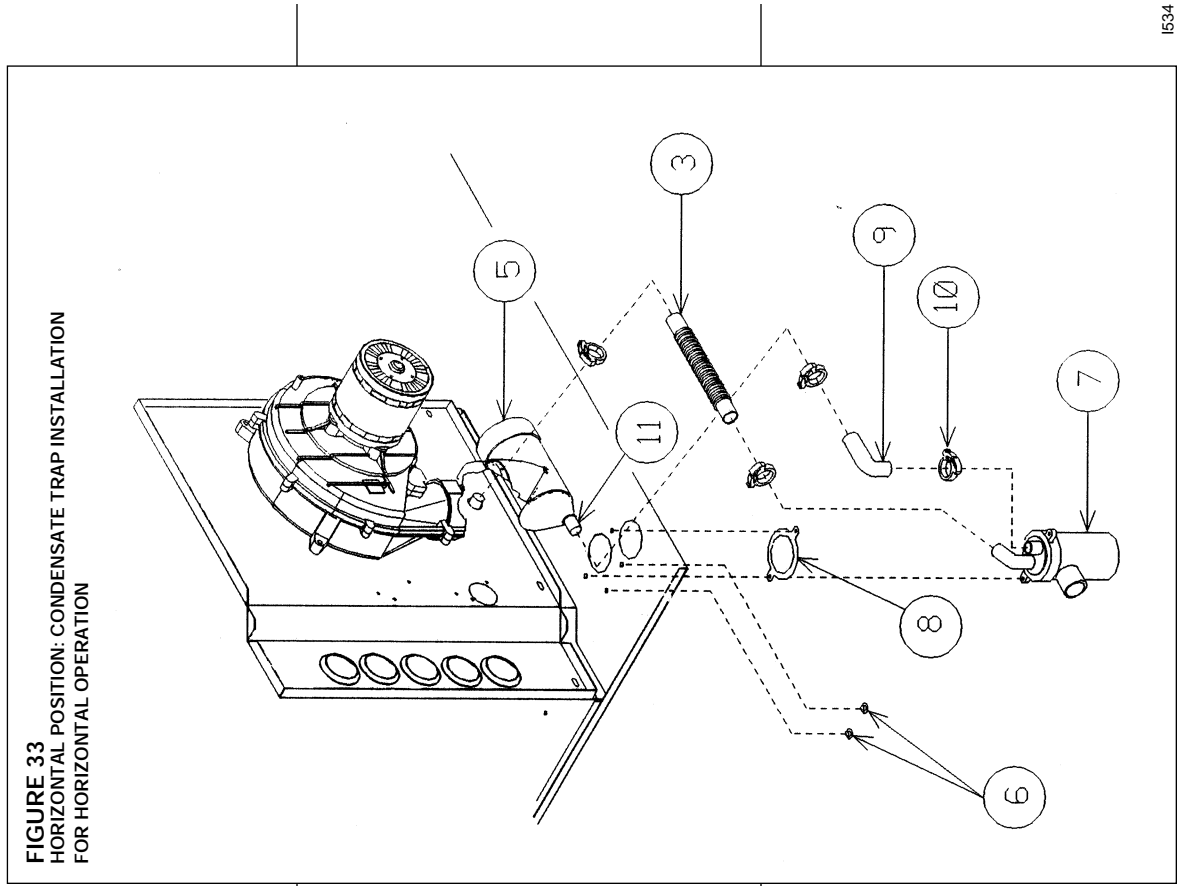
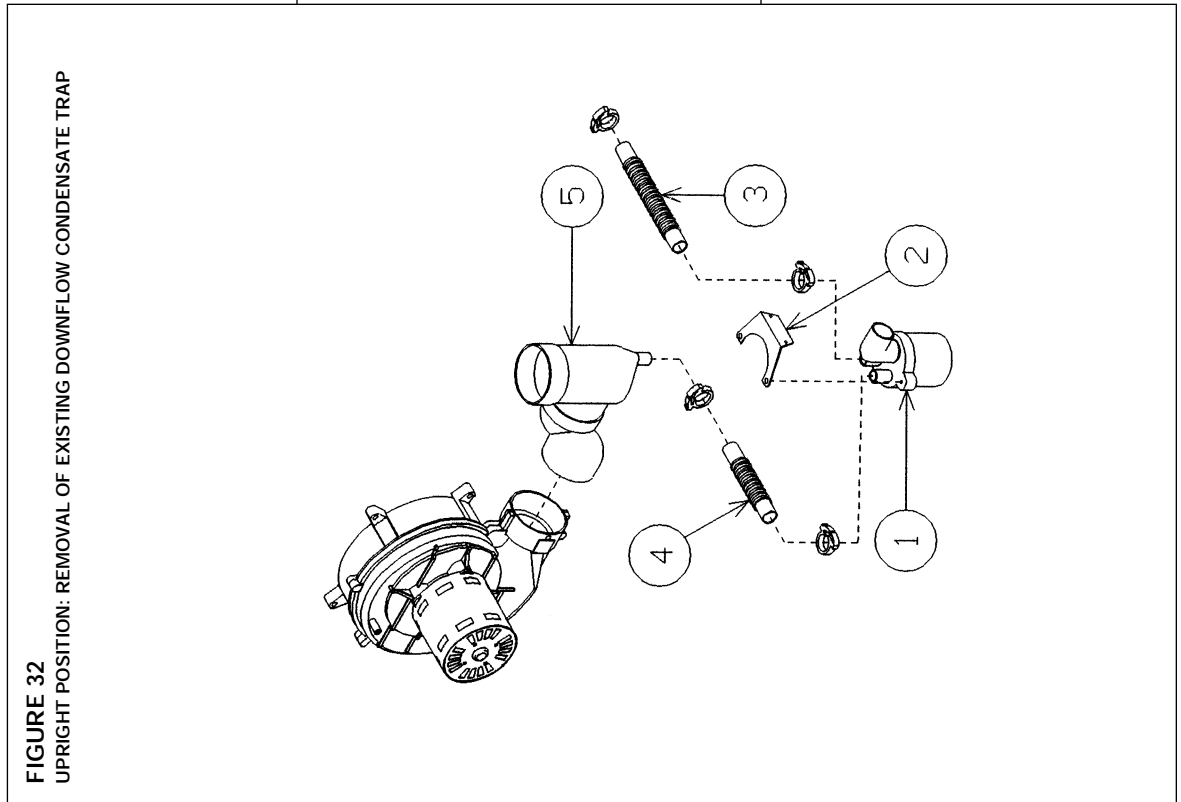

GAS SUPPLY AND PIPING

GAS SUPPLY

▲ WARNING

THIS FURNACE IS EQUIPPED AT THE FACTORY FOR USE ON NATURAL GAS ONLY. CONVERSION TO LP GAS REQUIRES A SPECIAL KIT SUPPLIED BY THE DISTRIBUTOR OR MANUFACTURER. MAILING ADDRESS IS LISTED ON THE WARRANTY. FAILURE TO USE THE PROPER CONVERSION KIT CAN CAUSE FIRE, CARBON MONOXIDE POISONING, EXPLOSION, PROPERTY DAMAGE, PERSONAL INJURY OR DEATH. See the conversion kit index supplied with the furnace. This index identifies the proper LP Gas Conversion Kit required for each particular furnace.

IMPORTANT: Any additions, changes or conversions required for the furnace to satisfactorily meet the application should be made by a qualified installer, service agency or the gas supplier, using factory-specified or approved parts.

IMPORTANT: Connect this furnace only to gas supplied by a commercial utility.

IMPORTANT: A U.L. recognized fuel gas and CO detector(s) are recommended in all applications, and their installation should be in accordance with the manufacturer's recommendations and/or local laws, rules, regulations or customs.

GAS PIPING

Install the gas piping according to all local codes and regulations of the utility company.

If possible, run a separate gas supply line directly from the meter to the furnace. Consult the local gas company for the location of the manual main shut-off valve. The gas line and manual gas valve must be adequate in size to prevent undue pressure drop and never smaller than the pipe size to the combination gas valve on the furnace. Refer to Table 3 for the recommended gas pipe size. See Figure 34 for typical gas pipe connections.

FIGURE 34
GAS PIPING INSTALLATION

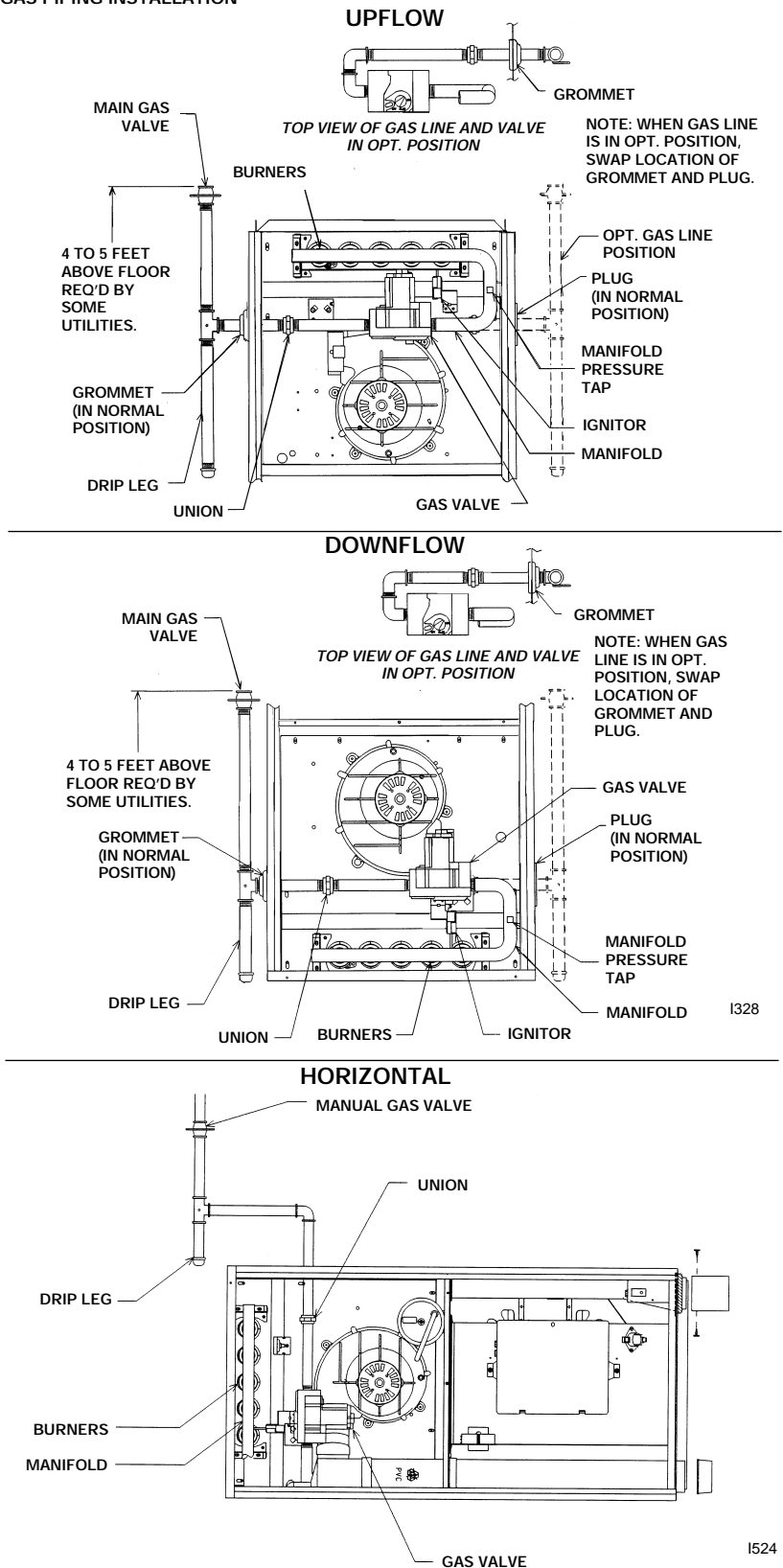

IMPORTANT: DO NOT RUN A FLEXIBLE GAS CONNECTOR INSIDE THE UNIT. Extend the 1/2" black pipe from the gas valve to the outside of the cabinet. Connect any flexible gas connector from there to the gas piping.

Install a ground joint union inside the cabinet to easily remove the control valve assembly. Install a manual shut-off valve in the gas line outside the furnace casing. The T-valve should be readily accessible to turn the gas supply on or off. Install a drip leg in the gas supply line as close to the furnace as possible. Always use a pipe compound resistant to the action of liquefied petroleum gases on all threaded connections.

IMPORTANT: *When making gas pipe connections, use a back-up wrench to prevent any twisting of the control assembly and gas valve.*

Any strains on the gas valve can change the position of the gas orifices in the burners. This can cause erratic furnace operation.

IMPORTANT: *Do not run a flexible gas connector inside the unit. If local codes allow the use of a flexible gas appliance connector, always use a new listed connector. Do not use a connector which has previously serviced another gas appliance. Massachusetts law requires that all flexible connectors be less than 36".*

The gas pipe gasket in the cabinet does not seal around a flexible gas connector. It is important to have all openings in the cabinet burner compartment sealed for proper furnace operation.

IMPORTANT: *ENSURE that the furnace gas control valve not be subjected to high gas line supply pressures.*

DISCONNECT the furnace and its individual shut-off valve from the gas supply piping during any pressure testing that exceeds 1/2 PSIG. (3.48 kPa).

GAS PRESSURE

Natural gas supply pressure should be 5" to 10.5" w.c. LP gas supply pressure should be 11" to 13" w.c. This pressure must be maintained with all other gas-fired appliances in operation.

The minimum supply pressure to the gas valve for proper furnace input adjustments is 5" w.c. for natural gas, however 6" to 7" is recommended. The minimum supply pressure is 11" w.c. for LP gas.

TABLE 3
NATURAL GAS PIPE CAPACITY TABLE (CU. FT./HR.)

Capacity of gas pipe of different diameters and lengths in cu. ft. per hr. with pressure drop of 0.3 in. and specific gravity of 0.60 (natural gas).

Nominal Iron Pipe Size, Inches	Length of Pipe, Feet							
	10	20	30	40	50	60	70	80
1/2	132	92	73	63	56	50	46	43
3/4	278	190	152	130	115	105	96	90
1	520	350	285	245	215	195	180	170
1-1/4	1,050	730	590	500	440	400	370	350
1-1/2	1,600	1,100	890	760	670	610	560	530

After the length of pipe has been determined, select the pipe size which will provide the minimum cubic feet per hour required for the gas input rating of the furnace. By formula:

$$\text{Cu. Ft. Per Hr. Required} = \frac{\text{Gas Input of Furnace (BTU/HR)}}{\text{Heating Value of Gas (BTU/FT}^3\text{)}}$$

The gas input of the furnace is marked on the furnace rating plate. The heating value of the gas (BTU/FT³) may be determined by consulting the local natural gas utility or the LP gas supplier.

▲ WARNING

NEVER PURGE A GAS LINE INTO THE COMBUSTION CHAMBER. NEVER USE MATCHES, FLAME OR ANY IGNITION SOURCE FOR CHECKING LEAKAGE. FAILURE TO ADHERE TO THIS WARNING CAN CAUSE A FIRE OR EXPLOSION RESULTING IN PROPERTY DAMAGE, PERSONAL INJURY OR DEATH.

To check for gas leakage, use an approved chloride-free soap and water solution, an electronic combustible gas detector (see Figure 35), or other approved method.

GAS VALVE

This furnace has a 24-volt operated valve. It has ports for measuring supply pressure and manifold pressure. The valve body contains a pressure regulator to maintain proper manifold pressure.

FIGURE 35
ELECTRONIC COMBUSTIBLE GAS DETECTOR



A manual control is on the valve body. It can be set to only the "ON" or "OFF" positions. The gas valve is a slow-opening valve. See Figure 36. When energized, it takes 6 to 8 seconds to fully open.

FIGURE 36
TYPICAL GAS VALVES

HONEYWELL

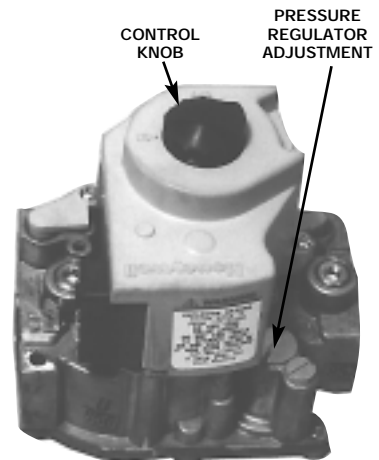

ROBERTSHAW

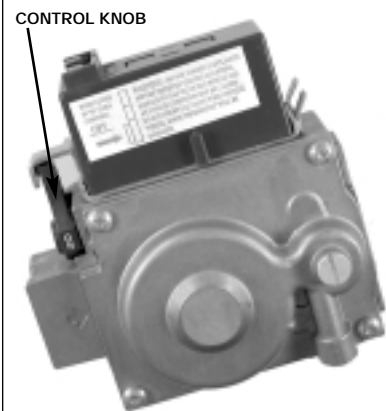

LP CONVERSION

NOTE: See Page 38 for Canadian High-Altitude Derate

IMPORTANT: LP gas from trucks used to transport liquid-based fertilizers can contain chemicals that will damage the furnace. Verify that your gas supplier does not use the same trucks to transport materials other than LP.

The valve can be converted to use liquified petroleum (LP) gas by replacing the pressure regulator spring with the conversion kit spring. This LP kit spring allows the regulator to maintain the proper manifold pressure for LP gas. The correct burner LP orifices are included in the kit. See Figure 37.

NOTE: Order the correct LP conversion kit from the furnace manufacturer. *Furnace conversion to LP gas must be performed by a qualified installer, service agency or the gas supplier.*

To change orifice spuds for either conversion to LP or for elevation:

1. Shut off the manual main gas valve and remove the gas manifold.
2. Replace the orifice spuds.
3. Reassemble in reverse order.

Consult the following table if there is any question concerning orifice sizing.

ORIFICE SIZES		
US	0 - 7999 FT.	8000 FT. & ABOVE
Natural Gas	#50	#51
LP Gas	1.15 mm	1.10 mm
CANADIAN	0 - 2000 FT.	2001-4500 FT.
Natural Gas	#50	#50
LP Gas	1.15 mm	1.15 mm

4. Turn the gas supply back on and check for proper operation and manifold pressure. See Figures 37, 38 and 39.
5. Attach the notice label alerting the next service technician that the furnace has been converted to LP gas.

FIGURE 37
TYPICAL LP KIT CONTENTS

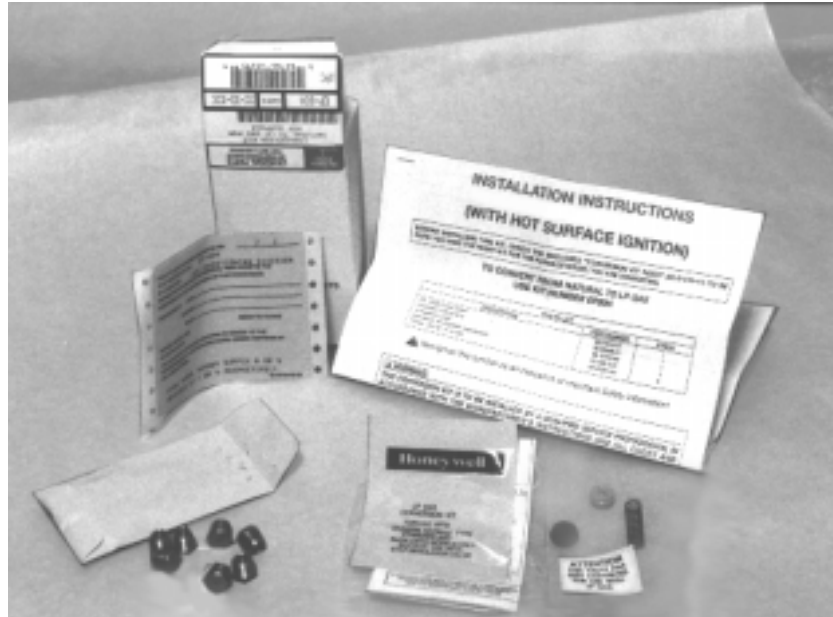

SETTING GAS PRESSURE

The maximum gas supply pressure to the furnace should be 10.5" w.c. natural gas, or 13" w.c. LP gas. The minimum supply gas pressure to the gas valve should be 5" w.c. natural gas or 11" w.c. LP gas. A properly calibrated U-Tube manometer is required for accurate gas pressure measurements.

Supply Gas Pressure Measurement. A line pressure tap is on the input side of the gas valve. See Figure 39.

1. With gas shut off to the furnace at the manual gas valve outside the unit, remove the input pressure tap plug.
2. Connect a U-Tube manometer to the pressure tap.

3. Turn on the gas supply and operate the furnace and all other gas-fired units on the same gas line as the furnace.
4. Note or adjust the line gas pressure to give:
 - A. 5" - 10.5" w.c. for natural gas.
 - B. 11" - 13" w.c. for LP gas.
5. Shut off the gas at the manual gas valve and remove the U-Tube manometer.
6. Replace the pressure tap plug before turning on the gas.

If the supply gas line pressure is above these ranges, install an in-line gas regulator to the furnace for natural gas units. With LP gas, have

the LP supplier reduce the line pressure at the regulator.

If supply gas line pressure is below these ranges, either remove any restrictions in the gas supply piping or enlarge the gas pipe. See Tables 3 and 4. With LP gas, have the LP supplier adjust the line pressure at the regulator.

Manifold Gas Pressure Measurement. Natural gas manifold pressure should be 3.5" w.c. LP gas manifold pressure should be 10.0" w.c. Only small variations in gas pressure should be made by adjusting the pressure regulator.

1. With the gas to the unit shut off at the manual gas valve, remove the pressure tap plug in the gas manifold. See Figure 38.
2. Connect a U-Tube manometer to this pressure tap. See Figure 39.
3. Turn on the gas supply and operate the furnace.
4. Note or adjust the manifold gas pressure to give:
 - A. 3.5" w.c. for natural gas.
 - B. 10.0" w.c. for LP gas.
5. To adjust the pressure regulator, remove the regulator cap.
6. Turn the adjustment screw clockwise to increase pressure, or counterclockwise to decrease pressure.
7. Securely replace the regulator cap.
8. Shut off gas at the manual gas valve and remove the U-Tube manometer.
9. Replace the manifold pressure tap plug before turning on the gas.

FIGURE 39
MANIFOLD PRESSURE TAP

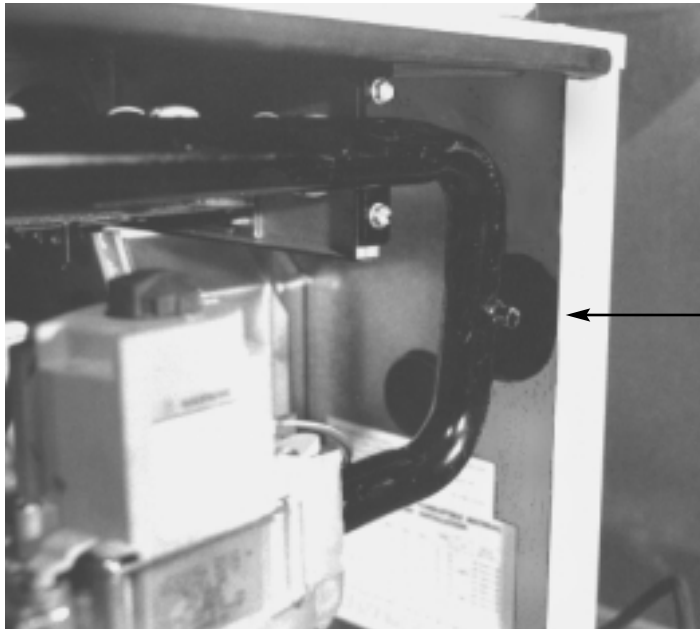

TABLE 4
LP GAS PIPE CAPACITY TABLE (CU. FT./HR.)

Maximum capacity of pipe in thousands of BTU per hour of undiluted liquefied petroleum gases (at 11 inches water column inlet pressure).

(Based on a Pressure Drop of 0.5 Inch Water Column)

Nominal Iron Pipe Size, Inches	Length of Pipe, Feet												
	10	20	30	40	50	60	70	80	90	100	125	150	
1/2	275	189	152	129	114	103	96	89	83	78	69	63	
3/4	567	393	315	267	237	217	196	182	173	162	146	132	
1	1,071	732	590	504	448	409	378	346	322	307	275	252	
1-1/4	2,205	1,496	1,212	1,039	913	834	771	724	677	630	567	511	
1-1/2	3,307	2,299	1,858	1,559	1,417	1,275	1,181	1,086	1,023	976	866	787	
2	6,221	4,331	3,465	2,992	2,646	2,394	2,205	2,047	1,921	1,811	1,606	1,496	

Example (LP): Input BTU requirement of unit, 120,000
Equivalent length of pipe, 60 ft. = 3/4" IPS required.

FIGURE 40
MANIFOLD PRESSURE READING

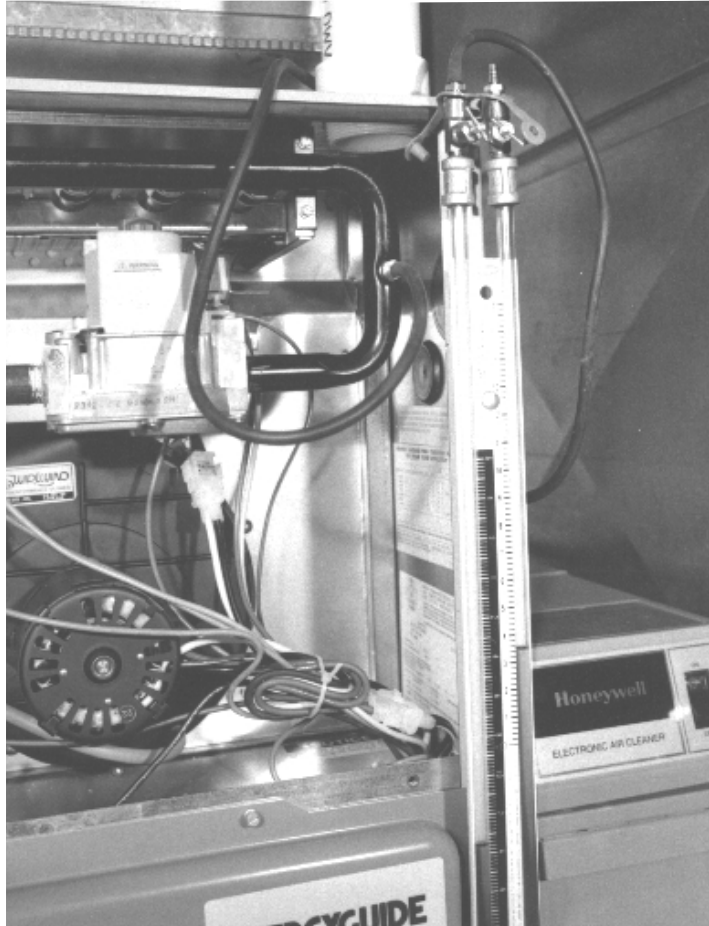
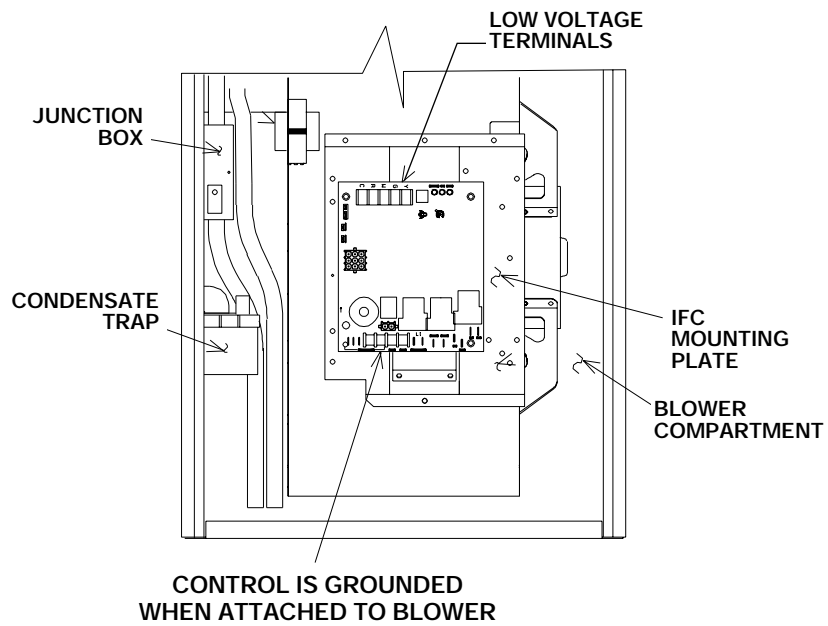

FIGURE 41
UPFLOW GROUNDING CONNECTIONS



1409-3

ALTERNATE METHOD FOR CANADIAN HIGH-ALTITUDE DERATE

In Canada, unless an orifice change is specifically mandated by local codes, an alternate method of altitude deration through a reduction in manifold pressure is acceptable as described in Table 5.

The information in Table 5 is based on a heating value of 1000 BTU per cubic feet of natural gas, and 2500 BTU per cubic feet of LP gas.

IMPORTANT: Actual input rates must be measured on-site with manifold pressure adjustment to ensure that an actual 10% reduction in input rate is achieved.

Once this field adjustment has been made, the label shown in Figure 42 must be affixed in a conspicuous location on the front of the furnace cabinet:

NOTE: This label is supplied in the information packet shipped with each furnace.

TABLE 5
ALTERNATE METHOD FOR CANADIAN HIGH-ALTITUDE DERATE

NATURAL GAS					LP GAS				
ALTITUDE	INPUT	OUTPUT	ORIFICE SIZE	MANIFOLD PRESSURE	ALTITUDE	INPUT	OUTPUT	ORIFICE SIZE	MANIFOLD PRESSURE
0' - 2000'	45,000	40,500	#50	3.5" W.C.	0' - 2000'	45,000	40,500	1.15mm	10" W.C.
	60,000	54,000				60,000	54,000		
	75,000	67,500				75,000	67,500		
	90,000	81,000				90,000	81,000		
	105,000	94,500				105,000	94,500		
	120,000	108,000				120,000	108,000		
2001' - 4500'	40,500	36,450	#50	3.0" W.C.	2001' - 4500'	40,500	36,450	1.15mm	7.6" W.C.
	54,000	48,600				54,000	48,600		
	67,500	60,750				67,500	60,750		
	81,000	72,900				81,000	72,900		
	94,500	85,050				94,500	85,050		
	108,000	97,200				108,000	97,200		

FIGURE 42
MANIFOLD PRESSURE-CHANGE LABEL

THE MANIFOLD PRESSURE OF THIS APPLIANCE HAS BEEN FIELD ADJUSTED TO OBTAIN THE CORRECT INPUT RATING FOR INSTALLATION AT ALTITUDES BETWEEN 2,000 FEET AND 4,500 FEET ELEVATION.

LA PRESSION DU DISTRIBUTEUR D'ALIMENTATION DE CET APPAREIL A ÉTÉ AJUSTÉ SUR LES LIEUX AFIN D'OBTENIR LA BONNE PUISSANCE D'ENTRÉE POUR UNE INSTALLATION ENTRE 2000 ET 4500 PIEDS D'ALTITUDE.

92-24399-01-01

ELECTRICAL WIRING

▲ WARNING

TURN OFF ELECTRIC POWER AT FUSE BOX OR SERVICE PANEL BEFORE MAKING ANY ELECTRICAL CONNECTIONS. FAILURE TO DO SO CAN CAUSE ELECTRICAL SHOCK RESULTING IN PERSONAL INJURY OR DEATH.

▲ WARNING

THE CABINET MUST HAVE AN UNINTERRUPTED GROUND ACCORDING TO THE LATEST EDITION OF THE NATIONAL ELECTRICAL CODE, ANSI/NFPA70- OR IN CANADA, THE CANADIAN ELECTRICAL CODE, CSA-C221 OR LOCAL CODES THAT APPLY. DO NOT USE GAS PIPING AS AN ELECTRICAL GROUND. A GROUND SCREW IS PROVIDED IN THE JUNCTION BOX. FAILURE TO DO SO CAN CAUSE ELECTRICAL SHOCK RESULTING IN PERSONAL INJURY OR DEATH.

▲ WARNING

THIS FURNACE IS EQUIPPED WITH A BLOWER DOOR SAFETY SWITCH. DO NOT DISABLE THIS SWITCH. FAILURE TO FOLLOW THIS WARNING CAN RESULT IN ELECTRICAL SHOCK, PERSONAL INJURY OR DEATH.

IMPORTANT: The furnace must be installed so that the electrical components are protected from water (condensate).

Before proceeding with the electrical connections, be certain that the voltage, frequency and phase corresponds to that specified on the furnace rating plate. For single furnace application, maximum over-current protection is 15 amperes.

Use a separate fused branch electrical circuit containing a properly sized fuse or circuit breaker. Run this circuit directly from the main switch box to an electrical disconnect that is readily accessible and located near the furnace. Connect from the electrical disconnect to the junction box on the left side of the furnace, inside the blower compartment. For the proper connection, refer to the

appropriate wiring diagram located on the inside cover of the furnace control box and in these instructions.

NOTE: UPFLOW MODELS ONLY

The electrical junction box may be moved to the right side if necessary. A knockout is provided. Seal the opposite hole with plug provided.

NOTE: L1 (hot) and L2 (neutral) polarity must be observed when making field connections to the furnace. The ignition control may not sense flame if L1 and L2 are reversed. See Figure 43.

Make all electrical connections in accordance with the latest edition of the National Electrical Code ANSI/NFPA70 and local codes having jurisdiction.

These may be obtained from:

National Fire Protection Association, Inc.
Batterymarch Park
Quincy, MA 02269

CSA - International
178 Rexdale Blvd.
Etobicoke (Toronto), Ontario
Canada M9W, 1R3

FIGURE 43
LINE VOLTAGE CONNECTIONS

UT ELECTRONIC CONTROLS 1028-928 CONTROL BOARDS

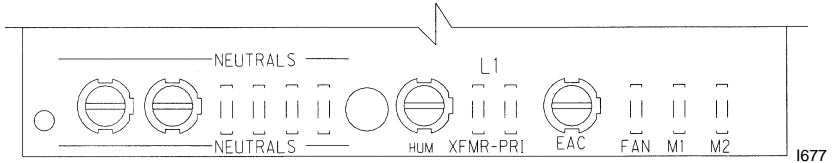

UT ELECTRONIC CONTROLS 1012-925 CONTROL BOARD

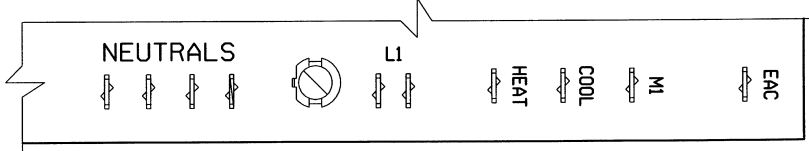
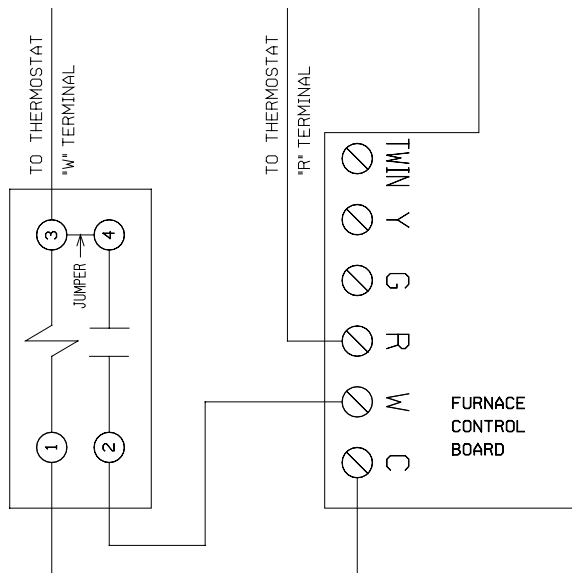

FIGURE 44
ISOLATION RELAY



ST-A0804-01

THERMOSTAT

The room thermostat must be compatible with the integrated furnace control on the furnace. Generally, all thermostats that are not of the "current robbing" type are compatible with the integrated furnace control. The low voltage wiring should be sized as shown.

NOTE: Do not use 24 volt control wiring smaller than No. 18 AWG.

NOTE: An isolation relay can be added to prevent any compatibility problems that may occur. Use a single-pole, single-throw relay with a 24-volt AC coil. The contacts should be rated for .5 amps minimum at 24 volts. See Figure 43.

Install the room thermostat in accordance with the instruction sheet packed in the box with the thermostat. Run the thermostat lead wires inside the blower compartment and connect to low voltage terminals as shown on the wiring diagram. Never install the thermostat on an outside wall or where it will be influenced by drafts, concealed hot or cold water pipes or ducts, lighting fixtures, radiation from fireplace, sun rays, lamps, televisions, radios or air streams from registers. Refer to instructions packed with the thermostat for "heater" selection or adjustment.

ACCESSORIES

FIELD-INSTALLED OPTION ACCESSORIES

ELECTRONIC AIR CLEANER

Line voltage power can be supplied from the screw terminal "EAC" and a line voltage neutral screw terminal on the control board. **NOTE:** Spade terminals only are provided on (-)GRJ and (-)GTJ models. This will power the electronic air cleaner whenever the circulating air blower is in operation.

HUMIDIFIER

Line voltage power can be supplied from screw terminal "HUM" to a line voltage neutral screw terminal on the control board. This will power the humidifier whenever the burner is on and the circulating air blower is operating in the heating mode.

NOTE: Maximum current – 1.0 amps for each option.

NOTE: Humidifier output is not available on (-)GRJ and (-)GTJ models.

HIGH ALTITUDE KIT

Models installed at altitudes of 5,000 feet and above require a pressure switch change. The installer must replace the induced draft blower pressure switch installed on the furnace with the new pressure switch. The burner orifices should also be changed (as indicated by the LP Conversion Kit Index).

NOTE: DO NOT make any attempt to derate the furnace for high altitudes by changing gas orifices or the gas pressure. Allow the natural derate of the gas to occur. Use the manufacturer's kit in conjunction with NFGC Section 8.1.2.

No orifice sizing or other derate procedures are necessary unless the natural gas exceeds 1075 BTU/cu. ft. at sea level or the LP gas exceeds 2500 BTU/cu. ft. at sea level. If the heating values exceed these levels, consult the manufacturer for the derate procedures.

FURNACE TWINNING INSTALLATIONS

Twinning operation of two furnaces, installed side-by-side, connected by a common duct system with main power supplied by the same source, and controlled by a common thermostat can be done with the UT Electronic Controls 1028-928 integrated control boards.

IMPORTANT: *Twinning of (-)GRJ- and (-)GTJ- units requires an accessory twinning kit. Refer to the specification sheet for proper kit. Do not attempt to twin these models by using the instructions below.*

IMPORTANT: *Only twin furnaces with identical control boards.*

IMPORTANT: *Only bottom returns can be used. No more than two furnaces can share the same supply and return. Furnaces must have same heating and blower capacity. Twinning furnaces must operate off the same phase of power.*

It should be noted that both blowers will run simultaneously when there is a call for heating, cooling or fan.

The "OK" LED will flash if twinning is not set up properly.

UT ELECTRONIC CONTROLS 1028-928 CONTROL BOARD

1. Single Stage Operation (See Figure 44)

- a. Control board "ONE" is on furnace connected to the thermostat.
- b. The 24 VAC supply to both control boards must be in phase with each other.
- c. Connect the "C," "W" and "TWIN" terminals to counterparts on each control.
- d. Both control boards must have switch #3 in the "ON" position.

2. Two Stage Operation (See Figure 45)

- a. Follow above instructions. Connect "W2" on thermostat to "W" on control board "TWO".

FIGURE 45
 UT Electronic Controls 1028-928 CONTROL BOARD, TWINNING CONNECTION -- SINGLE STAGE OPERATION

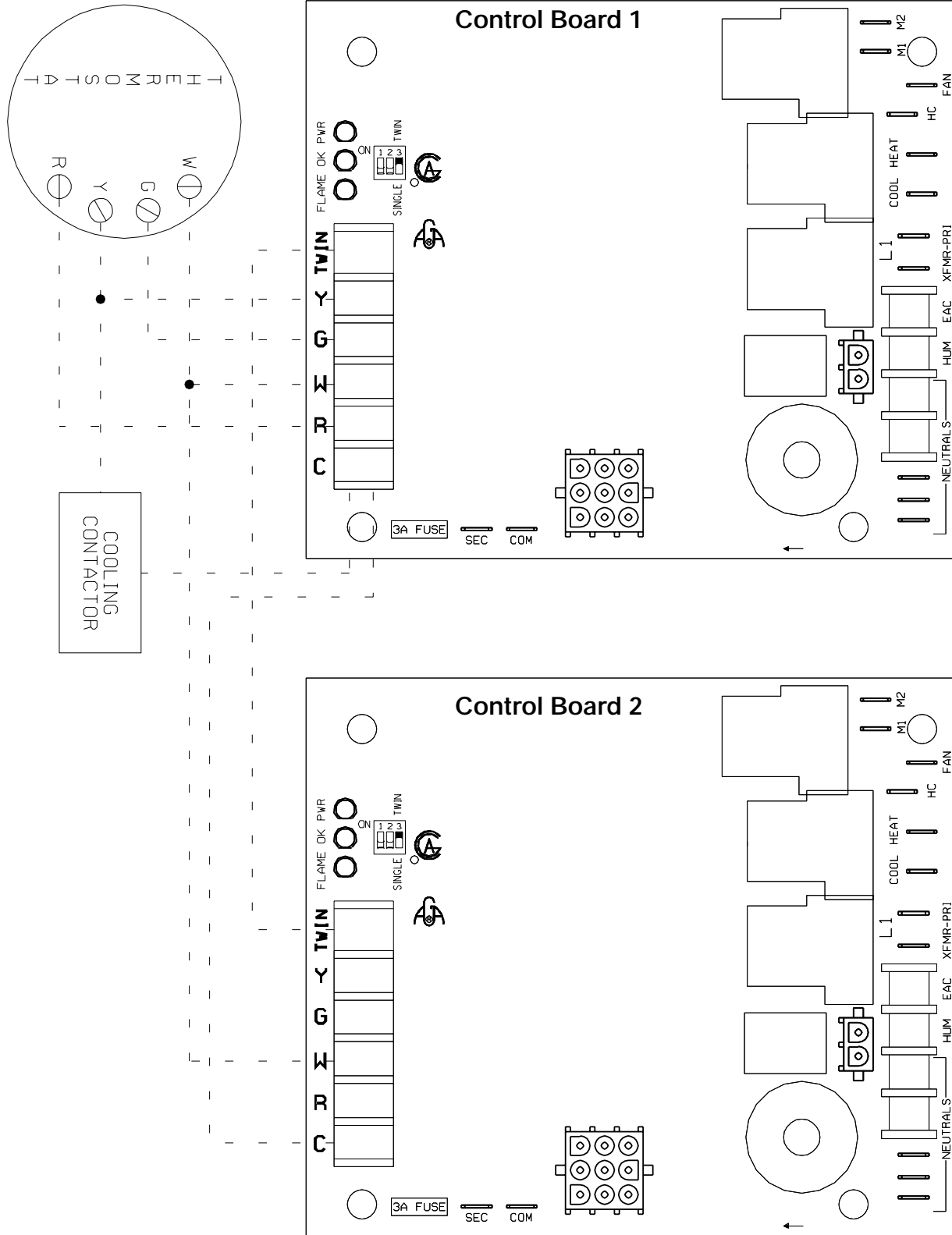
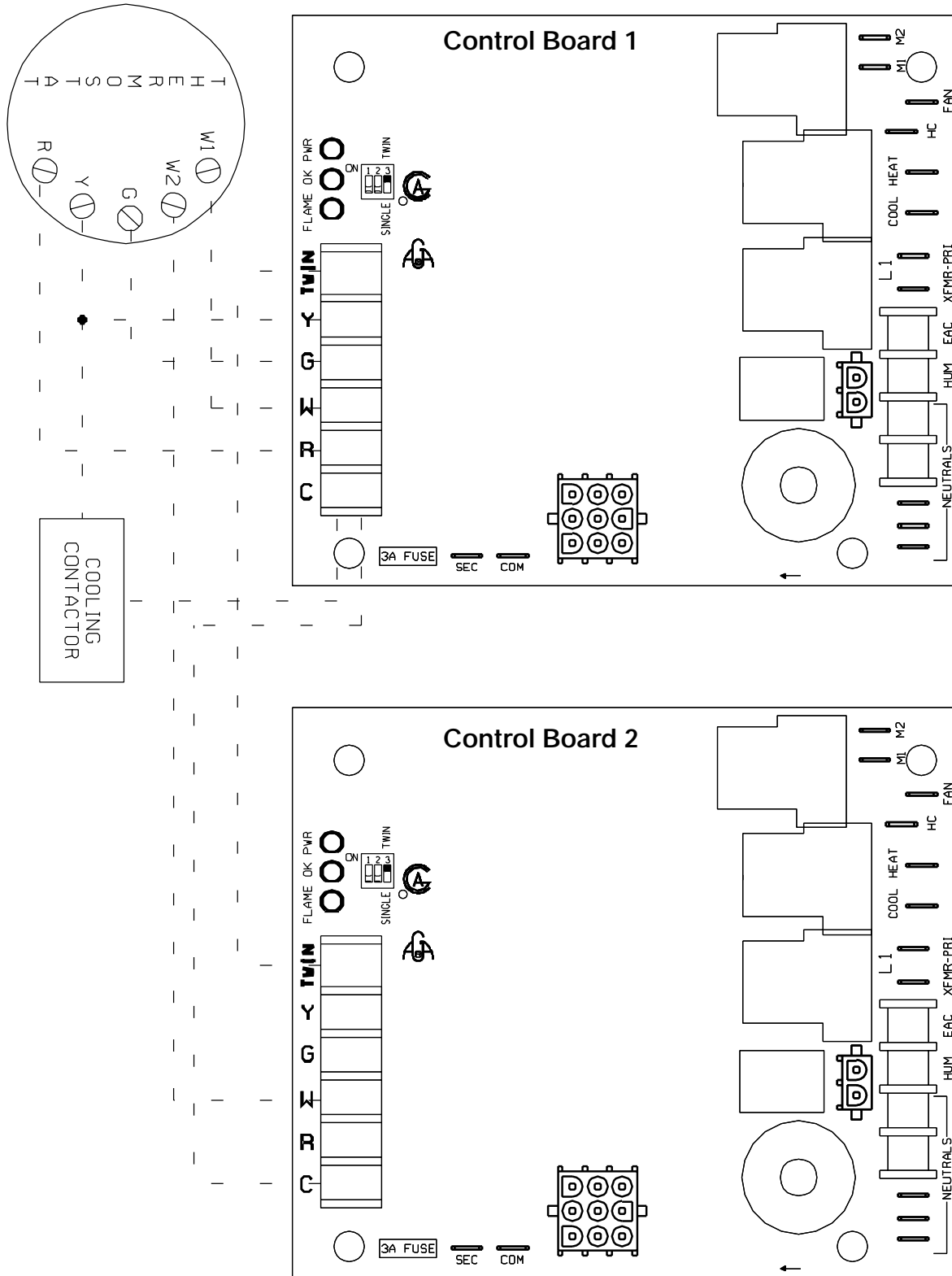

FIGURE 46

UT ELECTRONIC CONTROLS 1028-928 CONTROL BOARD, TWINNING CONNECTION -- TWO-STAGE OPERATION



START-UP PROCEDURES

This furnace is equipped with a direct ignition device. Each time the room thermostat calls for heat, the ignitor lights the main burners directly. See the lighting instructions on the furnace.

TO START THE FURNACE

1. Remove the burner compartment control access door.
2. **IMPORTANT:** Be sure that the manual gas control has been in the "OFF" position for at least five minutes. Do not attempt to manually light the main burners.
3. Turn off the furnace electrical power and set the room thermostat to its lowest setting.
4. Turn the gas control knob to the "ON" position or move the gas control lever to the "On" position.
5. Replace the burner compartment control access door.
6. Turn on the furnace electrical power.
7. Set the room thermostat to a point above room temperature to light the main burners.
8. After the burners are lit, set the room thermostat to a desired temperature.

TO SHUT DOWN THE FURNACE

1. Set the room thermostat to its lowest setting and wait for furnace to shut down.
2. Remove the burner compartment control access door.
3. Shut off the gas to the main burners by turning the gas control knob to the "OFF" position. See Figure 36.

▲ WARNING

SHOULD OVERHEATING OCCUR OR THE GAS SUPPLY FAIL TO SHUT OFF, CLOSE THE MANUAL GAS VALVE FOR THE APPLIANCE BEFORE SHUTTING OFF THE ELECTRICAL SUPPLY. FAILURE TO DO SO CAN CAUSE AN EXPLOSION OR FIRE RESULTING IN PROPERTY DAMAGE, PERSONAL INJURY OR DEATH.

SEQUENCE OF OPERATION

UT ELECTRONIC CONTROLS Integrated Controls with Hot Surface Ignition.

1. Each time the thermostat "W" (Heating) contacts close, the induced draft blower (inducer) begins a prepurge cycle.
2. The air proving negative pressure switch(es) closes.
3. **5 seconds after the pressure switch(es) close, the hot surface igniter begins heating for 30 seconds to full temperature.** The induced draft blower operates for the complete heating cycle.

4. After the 30-second igniter warm up, **the gas valve opens for an 8-second trial for ignition.**
5. The igniter lights the gas burners and **stays energized for the first 7 seconds after the gas valve opens.**
6. 8 seconds after the gas valve opens **the remote flame sensor must prove flame ignition for one second** using the process of flame rectification. If the burners don't light, the system goes through another ignition sequence. It does this **up to four times.**
7. The main blower starts approximately 20 seconds after the burners ignite.
8. When the thermostat "W" (Heat Call) ends, the gas valve closes, the burners go out, the induced draft blower stops after a **10-second post-purge**, and the negative pressure switch(es) open.
9. The main blower continues until timed off by the setting on the integrated furnace control board.

Sequence if the system doesn't light or doesn't sense flame:

1. On a call for heat, the control runs the inducer for 30 seconds to prepurge.
 2. 5 seconds into prepurge, the hot surface igniter heats for 30 seconds. The inducer continues to run.
 3. After the 30-second igniter warm up, the gas valve opens for an 8-second trial for ignition. The inducer continues and the igniter stays energized.
 4. If flame is not sensed during the 8th second after the gas valve opens, the gas valve closes, and the igniter de-energizes.
 5. After a 10-second post-purge, the inducer stops and the control verifies that the pressure switch has opened. Once the open pressure switch is confirmed, the control begins the next ignition cycle by energizing the inducer for a pre-purge of 30 seconds. After the 30-second pre-purge, the igniter energizes and begins a 30-second warm-up period (inducer is still running). After a 30-second igniter warm-up period, the gas valve opens and the control looks for a flame signal for up to 8 seconds. If no flame is sensed, the control goes into "self-healing" mode, in which the blower and inducer both run for three minutes before another ignition attempt is made.
- NOTE: The following applies only to units manufactured before third Quarter 2003:** After 5-second inter-purge, the control begins a 30-second pre-purge followed by a 30-second igniter warm-up period (inducer is still running). After the 30-second igniter warm-up period, the

gas valve opens and the control looks for a flame signal for up to 8 seconds. If no flame is sensed, the control goes into "self-healing" mode, in which the blower and inducer both run for three minutes before another ignition attempt is made.

6. The control attempts to ignite up to four times (first attempt followed by three retries). After the fourth failure to ignite, the control goes into a one-hour "soft-lockout," during which the control will not respond to the thermostat heat call (W). The lockout can be reset by shutting off main power to the furnace for five seconds, or by turning the heat call (W) from the thermostat off and then back on. Note that second and fourth ignition attempts will have a 30-second pre-purge followed by a 30-second igniter warm-up period. This prevents the igniter from overheating.
7. The above sequence will repeat after a one hour delay. It will continue repeating until ignition is successful or the call for heat is terminated.
8. **To reset the lock out, make and break power either at the thermostat or at the unit disconnect switch for 5 to 10 seconds.** It then goes through another set of trials for ignition.

UT Electronic Controls Direct Spark Ignition

1. Each time the thermostat contacts close, the induced draft blower (inducer) begins a prepurge cycle.
2. The air proving negative pressure switch(es) closes.
3. **30 seconds after the pressure switch(es) close, the spark igniter energizes.** The induced draft blower operates for the complete heating cycle.
4. After the spark igniter energizes, **the gas valve opens for a 8 second trial for ignition.**
5. The igniter lights the gas burners.
6. After the gas valve opens **the flame sensor must prove flame ignition for one second** using the process of flame rectification. If the burners don't light, the system goes through another ignition sequence. It does this **up to four times.**
7. The main blower starts 20 seconds after the burners ignite.
8. When the thermostat cycle ends, the gas valve closes, the burners go out, the induced draft blower stops after a **10-second post-purge**, and the negative pressure switch(es) open.
9. The main blower continues until timed off by the setting on the integrated furnace control board.

Sequence if the system doesn't light or doesn't sense flame:

1. On a call for heat, the control runs the inducer for 30 seconds to pre-purge.
 2. After the 30-second pre-purge, the spark igniter energizes. The inducer continues to run.
 3. After the spark igniter energizes, the gas valve opens for an 8-second trial for ignition. The inducer continues and the igniter stays energized.
 4. If flame is not sensed within 8 seconds after the gas valve opens, the gas valve closes, the igniter de-energizes and:
 5. The inducer completes a 10-second post-purge, the inducer stops, and the control verifies that the pressure switch has opened. Once the open pressure switch is confirmed, the control begins the next ignition cycle by energizing the inducer for a pre-purge of 30 seconds. After the pre-purge, the igniter energizes and the gas valve opens (inducer continues to run). If no flame is sensed on the second attempt, the control goes into a "self-healing" mode, in which the blower and the inducer run for 3 minutes before another ignition attempt is made.
- NOTE: The following applies only to units manufactured before third Quarter 2003:** After a 30-second inter-purge (inducer runs continuously), the igniter is energized, and the gas valve opens for 8 seconds. If flame is not sensed in 8 seconds, the gas valve is closed and the igniter de-energizes. If no flame is sensed on this second attempt, the control goes into a "self-healing" mode, in which the blower and inducer run for 3 minutes before another ignition attempt is made.
6. The control attempts to ignite up to four times (first attempt followed by three retries). After the fourth failure to ignite, the control goes into a one-hour "soft-lockout" during which the control will not respond to the thermostat heat call (W). The lockout can be reset by shutting off main power to the furnace for five seconds, or by turning the heat call (W) from the thermostat off and then back on.
 7. The above sequence will repeat after a one hour delay. It will continue repeating until ignition is successful or the call for heat is terminated.
 8. To reset the lock out, make and break power either at the thermostat or at the unit disconnect switch for 5 to 10 seconds. It then goes through another set of trials for ignition.

METER TIME IN MINUTES AND SECONDS FOR NORMAL INPUT RATING OF FURNACES EQUIPPED FOR NATURAL OR LP GAS											
INPUT BTU/HR	METER SIZE CU. FT.	HEATING VALUE OF GAS BTU PER CU. FT.									
		900		1000		1040		1100		2500 (LP)	
		MIN.	SEC.	MIN.	SEC.	MIN.	SEC.	MIN.	SEC.	MIN.	SEC.
45,000	ONE	1	12	1	20	1	23	1	28	3	20
	TEN	12	0	13	20	13	50	14	40	33	20
60,000	ONE	0	54	1	0	1	3	1	6	2	30
	TEN	9	0	10	0	10	24	11	0	25	0
75,000	ONE	0	44	0	48	0	50	0	53	2	0
	TEN	7	12	8	0	8	19	8	48	20	0
90,000	ONE	0	36	0	40	0	42	0	44	1	40
	TEN	6	0	6	40	7	0	7	20	16	40
105,000	ONE	0	31	0	34	0	36	0	38	1	26
	TEN	5	10	5	40	6	0	6	20	14	20
120,000	ONE	0	27	0	30	0	31	0	33	1	15
	TEN	4	30	5	0	5	10	5	30	12	30

Formula: Input BTU/HR = $\frac{\text{Heating Value of Gas (BTU/FT}^3\text{) x 3600 x correction factor}}{\text{Time in Seconds (for 1 cu. ft.) of Gas}}$

ADJUSTING OR CHECKING FURNACE INPUT

The maximum gas supply pressure to the furnace should be 7" w.c. for natural gas. The minimum gas supply pressure for purposes of input adjustment to the furnace should be 5" w.c.

A properly calibrated magnehelic gauge or manometer is required for accurate gas pressure readings.

The manifold pressure should be set at 3.5" w.c. for natural gas. Only small variations in the gas flow should be made by means of the pressure regulator adjustment. In no case should the final manifold pressure vary more than plus or minus 0.3" w.c. from the above-specified pressures. To adjust the pressure regulator, remove the regulator cap and turn the adjustment screw clockwise to increase pressure or counterclockwise to decrease pressure. Then replace the regulator cap securely. Any necessary major changes in the gas flow rate should be made by changing the size of the burner orifices.

To change orifice spuds, shut off the manual gas valve and remove the gas manifold. On LP gas furnaces, the LP gas supply pressure must be set between 11" and 14" w.c. by means of the tank or branch supply regulators. The furnace manifold pressure should be set at 10" w.c. at the gas control valve. For elevations up to 2,000 feet, rating plate input

ratings apply. For high altitudes (elevations over 2,000 ft.), see conversion kit index for derating and orifice spud sizes.

Checking furnace input is important to prevent over firing beyond its design-rated input. NEVER SET INPUT ABOVE THAT SHOWN ON THE RATING PLATE. Use the following table or formula to determine input rate. Start the furnace and measure the time required to burn one cubic foot of gas. Prior to checking the furnace input, make certain that all other gas appliances are shut off, with the exception of pilot burners. Time the meter with only the furnace in operation.

SETTING INPUT RATE

The furnace is shipped from the factory with #50 orifices. They are sized for natural gas having a heating value of 1075 BTU/cu. ft. and a specific gravity of .60.

Since heating values vary geographically, the manifold pressure and/or gas orifice size may need to be changed to adjust the furnace to its nameplate input. Consult the local gas utility to obtain the yearly average heating value and orifice size required to fire each individual burner at 15,000 BTU/HR.

NOTE: Refer to the National Fuel Gas Code for high altitude rate adjustment above 2,000 ft.

AIR FLOW

The importance of proper air flow over the heat exchanger cannot be over emphasized. One of the most common causes of heat exchanger failure is overheating due to low air flow. An air flow table is located inside the blower door.

TEMPERATURE RISE CHECK

To determine if the air flow is correct, make a temperature rise check.

1. Insert a thermometer in the supply air duct as close to the furnace as possible yet out of a direct line from the heat exchanger. See Figure 47.
2. Insert a thermometer in the return air duct as close to the furnace as possible.
3. Operate the furnace.
4. When the thermometer in the supply air duct stops rising (approximately five minutes), subtract the return air temperature from the supply air temperature. The difference is the temperature rise.
5. Compare the measured temperature rise to the approved temperature rise range listed on the furnace name plate. See Figure 48.

If the measured temperature rise is above the approved range, the air flow is too low. More air must be moved by speeding up the blower, by removing restrictions in the duct system, or by adding more supply or return air duct. If the measured temperature rise is below the approved range, the air flow is too much. Use lower speed tap on the multi-speed blower.

WARNING

THE MEASURED TEMPERATURE RISE SHOULD BE AS CLOSE TO THE MIDDLE OF THE STATED RANGE AS POSSIBLE. FOR EXAMPLE, IF THE RISE RANGE IS 40 TO 70 DEGREES, THE MOST IDEAL RISE WOULD BE 55 DEGREES (THE MIDDLE OF THE RISE RANGE). IN ALL APPLICATIONS, THE INSTALLER MUST ADJUST THE TEMPERATURE RISE TO THIS "MIDDLE" POINT AS CLOSELY AS POSSIBLE. ALSO, THE TEMPERATURE RISE SHOULD NEVER BE ABOVE OR FALL BELOW THE STATED RANGE. DOING SO COULD CAUSE DAMAGE TO THE HEAT EXCHANGER OR INTERMITTENT OPERATION WHICH COULD CAUSE INJURY OR DEATH AND WILL VOID THE MANUFACTURER'S WARRANTY FOR THIS PRODUCT.

FIGURE 47
TEMPERATURE RISE MEASUREMENT



FIGURE 48
TYPICAL FURNACE NAME PLATE



AIR CONDITIONING DIVISION
FORT SMITH, ARKANSAS



DESHA
CHAMBER OF COMMERCE



ETL
VERIFIED

CANADIAN ENERGY PERFORMANCE VERIFIED

RENDIMENT ENERGETIQUE VERIFIE

MODEL NO./NUMERO DE MODELE: _____
SERIAL NO./NUMERO DE SERIE: _____

CATEGORY IV FORCED AIR FURNACE WHEN USING INDOOR AIR FOR COMBUSTION. CATEGORY IV TYPE FSP DIRECT VENT FORCED AIR FURNACE WHEN USING OUTDOOR AIR FOR COMBUSTION. FOR INDOOR INSTALLATION ONLY. IN A BUILDING CONSTRUCTED ON-SITE.
CATEGORIE IV GENERATEUR D'AIR CHAUD A AIR FORCEE LORSQUE DE L'AIR INTERIEUR EST EMPLOYE POUR LA COMBUSTION. CATEGORIE IV TYPE FSP EVACUATION DIRECTE GENERATEUR D'AIR CHAUD A AIR FORCEE LORSQUE DE L'AIR EXTERIEUR EST EMPLOYE POUR LA COMBUSTION. POUR INSTALLATION A L'INTERIEUR SEULEMENT, DANS UN BATIMENT CONSTRUIT SUR LE SITE.

ELECTRIC 115 V. 60 HZ 1 PH. MAXIMUM TOTAL INPUT **6.3** AMPS.
ELECTRIQUE 115 V. 60 HZ 1 PH. PUISSANCE D'ENTREE TOTALE MAXIMUM **6.3** A.
MAXIMUM OVERCURRENT PROTECTION 15 AMPERES. DISJONCTEUR A MAXIMA 15 A.

HOURLY INPUT RATING DEBIT CALORIFIQUE MAXIMUM Btu/hr	(Kw)	HOURLY INPUT RATING DEBIT CALORIFIQUE MINIMUM Btu/hr	(Kw)	FACTORY EQUIPPED FOR AGENCE A L'USINE POUR FOR GAS / GAZ
75,000 (21.98)		52,500 (15.39)		NATURAL / NATUREL

THIS APPLIANCE EQUIPPED FOR ALTITUDES/CET APPAREIL EST EQUIPE POUR ALTITUDES COMPRISES ENTRE 0 - 2,000 (0-610) (CANADA ONLY) FT.(M)/PIEDS(M)

ORIFICE/ INJECTEUR # 50 DMS (CANADA ONLY) NATURAL GAS/ LP GAS OR PROP./
LIMIT SETTING/LIMITE COUPE-CIRCUIT 200 (93) °F[°C] GAZ NATUREL GAZ DE PETROLE LIQUEFIE OU PROP.

AUXILIARY LIMIT SETTING/ LIMITE COUPE-CIRCUIT AUXILIAIRE °F[°C]

	IN. W.C. (kPa)/ PO. C.E. (kPa)	IN. W.C. (kPa)/ PO. C.E. (kPa)
MAXIMUM PERMISSIBLE GAS SUPPLY PRESSURE TO FURNACE PRESSION MAXIMUM D'ALIMENTATION EN GAZ A CHAUDIERE	10.5 (2.61)	13.0 (3.23)
MINIMUM GAS SUPPLY PRESSURE FOR PURPOSES OF INPUT ADJUSTMENT PRESSION MINIMUM D'ALIMENTATION EN GAZ POUR LE REGLAGE DE PUISSANCE D'ENTREE	5.0 (1.24)	11.0 (2.73)
MANIFOLD PRESSURE/PRESSION A LA TUBULURE	5.0 (1.24)	11.0 (2.73)
MANIFOLD PRESSURE-LOW INPUT NAT. -1.7WC(4.32CM)/LP-4.9WC(12.45 CM)	3.5 (0.87)	10.0 (2.49)

AIR TEMPERATURE RISE/
AUGMENTATION DE LA TEMPERATURE DE L'AIR **45 (25) TO 75 (42)** °F(°C)

MAXIMUM EXTERNAL STATIC PRESSURE PRESSION STATIQUE EXTERIEURE MAXIMAL INCHES W.C. (kPa)-PO. C.E. (kPa)	BLOWER/ SOUFFLEUR INCH (mm)/PO. (mm)	MOTOR FORCE HP (W)
.12 (.125)	11-7 (279-178)	1/2 (373)
.50 (.125)	11-7 (279-178)	1/2 (373)

ANSI Z21.47a * CSA 2.3a -2001 CENTRAL FURN. MADE IN THE USA 91-22176-09

**TABLE 7
90 PLUS AIR FLOW PERFORMANCE – (-)GRA & (-)GTA MODELS**

MODEL	BLOWER/ MOTOR HP	SPEED	CFM @ ESP						
			.1	.2	.3	.4	.5	.6	.7
(-)GRA-04	11 x 7 / 1/2	LOW	805	780	760	720	685	645	605
		*M-LO	920	885	850	810	775	730	690
		M-HI	1140	1110	1085	1045	1010	950	890
		HIGH	1360	1320	1280	1235	1195	1140	1080
(-)GTA-04	11 x 7 / 1/2	LOW	820	790	760	725	690	650	610
		*M-LO	930	890	850	815	785	750	720
		M-HI	1150	1120	1090	1045	1002	950	900
		HIGH	1414	1365	1320	1270	1220	1165	1115
(-)GRA-06	11 x 7 / 1/2	LOW	770	740	710	675	645	605	570
		*M-LO	880	845	815	790	760	715	670
		M-HI	1060	1025	990	960	925	880	835
		HIGH	1260	1215	1175	1135	1100	1040	985
(-)GTA-06	11 x 7 / 1/2	LOW	795	760	730	695	660	615	570
		*M-LO	910	885	860	815	770	725	680
		M-HI	1115	1080	1045	1005	965	920	875
		HIGH	1365	1315	1270	1225	1180	1125	1070
(-)GRA-07	11 X 7 / 1/2	LOW	780	745	710	675	640	595	555
		M-LO	880	850	825	785	750	702	655
		*M-HI	1090	1050	1010	970	925	875	825
		HIGH	1300	1255	1210	1160	1110	1055	1005
(-)GTA-07	11 X 7 / 1/2	LOW	780	750	720	675	635	595	555
		M-LO	890	860	835	790	750	705	660
		*M-HI	1100	1060	1025	980	940	890	845
		HIGH	1340	1295	1250	1200	1150	1090	1025
(-)GRA-07	12 X 7 1/2 / 3/4	LOW	1105	1095	1080	1050	1030	1010	990
		M-LO	1290	1275	1260	1220	1195	1170	1140
		M-HI	1480	1435	1415	1390	1370	1300	1255
		HIGH	1705	1665	1615	1570	1540	1475	1400
(-)GTA-07	12 X 7 1/2 / 3/4	LOW	1185	1160	1140	1115	1095	1065	1040
		M-LO	1405	1375	1350	1310	1270	1235	1195
		M-HI	1595	1560	1525	1480	1440	1380	1325
		HIGH	1835	1780	1730	1675	1625	1555	1480
(-)GRA-09	12 X 11 / 3/4	LOW	1235	1210	1185	1150	1120	1075	1035
		*M-LO	1490	1465	1440	1405	1375	1315	1255
		M-HI	1720	1670	1620	1600	1580	1520	1460
		HIGH	2100	2050	2000	1955	1910	1825	1745
(-)GTA-09	12 X 11 / 3/4	LOW	1155	1125	1100	1080	1060	1000	940
		*M-LO	1420	1400	1380	1365	1350	1260	1175
		M-HI	1605	1575	1550	1560	1570	1480	1390
		HIGH	2005	1965	1930	1890	1850	1765	1680
(-)GRA-10	12 X 11 / 3/4	LOW	1230	1205	1180	1155	1130	1090	1050
		*M-LO	1490	1445	1405	1375	1350	1295	1240
		M-HI	1710	1665	1620	1580	1540	1475	1410
		HIGH	2010	1955	1900	1855	1810	1710	1610
(-)GTA-10	12 X 11 / 3/4	LOW	1180	1150	1120	1100	1080	1025	970
		*M-LO	1460	1425	1390	1375	1360	1280	1200
		M-HI	1680	1645	1615	1585	1560	1490	1420
		HIGH	2055	2000	1940	1880	1820	1745	1675
(-)GRA-12	11 X 10 / 3/4	LOW	1320	1305	1290	1260	1230	1185	1140
		*M-LO	1610	1580	1555	1515	1475	1415	1355
		M-HI	1870	1820	1775	1715	1660	1590	1520
		HIGH	2115	2050	1990	1945	1900	1795	1690
(-)GTA-12	11 X 10 / 3/4	LOW	1285	1250	1215	1235	1260	1230	1200
		*M-LO	1590	1565	1540	1505	1475	1425	1375
		M-HI	1840	1820	1800	1750	1700	1645	1590
		HIGH	2315	2250	2185	2110	2040	1965	1890

* Heating speed for cooling applications
NOTE: Units tested with filters in place.

TABLE 8

90 PLUS AIR FLOW PERFORMANCE – (-)GRJ & (-)GTJ MODELS

MODEL	BLOWER/ MOTOR HP	SPEED	CFM @ ESP						
			.1	.2	.3	.4	.5	.6	.7
(-)GRJ-04	11 x 7 / 1/2	LOW	805	780	760	720	685	645	605
		MED-LO	920	885	850	810	775	730	690
		MED-HI	1140	1110	1085	1045	1010	950	890
		HIGH	1360	1320	1280	1235	1195	1140	1080
(-)GTJ-04	11 x 7 / 1/2	LOW	820	790	760	725	690	650	610
		MED-LO	930	890	850	815	785	750	720
		MED-HI	1150	1120	1090	1045	1002	950	900
		HIGH	1414	1365	1320	1270	1220	1165	1115
(-)GRJ-06	11 x 7 / 1/2	LOW	880	845	815	790	760	715	670
		MED	1060	1025	990	960	925	880	835
		HIGH	1260	1215	1175	1135	1100	1040	985
(-)GTJ-06	11 x 7 / 1/2	LOW	910	885	860	815	770	725	680
		MED	1115	1080	1045	1005	965	920	875
		HIGH	1365	1315	1270	1225	1180	1125	1070
(-)GRJ-07	11 X 7 / 1/2	LOW	880	850	825	785	750	702	655
		MED	1090	1050	1010	970	925	875	825
		HIGH	1300	1255	1210	1160	1110	1055	1005
(-)GTJ-07	11 X 7 / 1/2	LOW	890	860	835	790	750	705	660
		MED	1100	1060	1025	980	940	890	845
		HIGH	1340	1295	1250	1200	1150	1090	1025
(-)GRJ-07	12 X 7 / 1/2	LOW	1185	1160	1140	1115	1095	1065	1040
		MED	1405	1375	1350	1310	1270	1235	1195
		HIGH	1595	1560	1525	1480	1440	1380	1325
(-)GTJ-07	12 X 7 / 1/2	LOW	1105	1095	1080	1050	1030	1010	990
		MED	1290	1275	1260	1220	1195	1170	1140
		HIGH	1480	1435	1415	1390	1370	1300	1255
(-)GRJ-07	12 X 7 / 3/4	LOW	1405	1375	1350	1310	1270	1235	1195
		MED	1595	1560	1525	1480	1440	1380	1325
		HIGH	1835	1780	1730	1675	1625	1555	1480
(-)GTJ-07	12 X 7 / 3/4	LOW	1290	1275	1260	1220	1195	1170	1140
		MED	1480	1435	1415	1390	1370	1300	1255
		HIGH	1705	1665	1615	1570	1540	1475	1400
(-)GRJ-09	12 X 11 / 1/2	LOW	1235	1210	1180	1150	1120	1075	1035
		MED	1490	1465	1445	1405	1375	1315	1255
		HIGH	1720	1670	1620	1600	1580	1520	1460
(-)GTJ-09	12 X 11 / 1/2	LOW	1155	1125	1100	1080	1060	1000	940
		MED	1420	1400	1380	1365	1350	1260	1175
		HIGH	1605	1575	1550	1560	1570	1480	1395
(-)GRJ-09	12 X 11 / 3/4	LOW	1490	1465	1445	1405	1375	1315	1255
		MED	1720	1670	1620	1600	1580	1520	1460
		HIGH	2100	2050	2000	1955	1910	1825	1745
(-)GTJ-09	12 X 11 / 3/4	LOW	1420	1400	1380	1365	1350	1260	1175
		MED	1605	1575	1550	1560	1570	1480	1395
		HIGH	2005	1965	1930	1890	1850	1765	1680
(-)GRJ-10	12 X 11 / 1/2	LOW	1230	1205	1180	1155	1130	1090	1050
		MED	1490	1445	1405	1375	1350	1295	1240
		HIGH	1710	1665	1620	1580	1540	1475	1410
(-)GTJ-10	12 X 11 / 1/2	LOW	1180	1150	1120	1100	1080	1025	970
		MED	1460	1425	1390	1375	1360	1280	1200
		HIGH	1680	1645	1615	1585	1560	1490	1420
(-)GRJ-10	12 X 11 / 3/4	LOW	1490	1445	1405	1375	1350	1295	1240
		MED	1710	1665	1620	1580	1540	1475	1410
		HIGH	2010	1955	1900	1855	1810	1710	1610
(-)GTJ-10	12 X 11 / 3/4	LOW	1460	1425	1390	1375	1360	1280	1200
		MED	1680	1645	1615	1585	1560	1490	1420
		HIGH	2055	2000	1940	1880	1820	1745	1675
(-)GRJ-12	11 X 10 / 1/2	LOW	1320	1305	1290	1260	1230	1185	1140
		MED	1610	1580	1555	1515	1475	1415	1355
		HIGH	1870	1820	1775	1715	1	1590	1520
(-)GTJ-12	11 X 10 / 1/2	LOW	1285	1250	1215	1235	1260	1230	1200
		MED	1590	1565	1540	1505	1	1425	1375
		HIGH	1840	1820	1800	1750	1700	1645	1590
(-)GRJ-12	11 X 10 / 3/4	LOW	1610	1580	1555	1515	1475	1415	1355
		MED	1870	1820	1775	1715	1660	1590	1520
		HIGH	2115	2050	1990	1945	1900	1795	1690
(-)GTJ-12	11 X 10 / 3/4	LOW	1590	1565	1540	1505	1475	1425	1375
		MED	1840	1820	1800	1750	1700	1645	1590
		HIGH	2315	2250	2185	2110	2040	1965	1890

* Heating speed for cooling applications
NOTE: Units tested with filters in place.

SETTING BLOWER TIMINGS

The Honeywell and UT ELECTRONIC CONTROLS control boards have three or four quick connect terminals for connecting the motor speed leads. These are:

1. FAN SPEED — motor runs on this speed when the thermostat is in the “FAN ON” position.
2. COOL — connect desired cooling speed.
3. HEAT — connect desired heating speed.
4. HEAT/COOL (not available on UT Electronic Controls-1028-925 control board) — connect desired speed when heating and cooling speed are the same.

IMPORTANT: Do not connect any motor speeds to “HEAT” and “COOL” if you use the “HEAT/COOL” terminal.

5. If heating and continuous fan speed are the same, “piggyback” jumper across “FAN” and “HEAT” terminals.

NOTE: This does not apply to (-)GRJ or (-)GTJ models. The heat tap functions as the continuous fan tap as well.

See Figures 49, 50 & 51 for instructions for setting the blower “OFF” timings.

If cooling speed and fan speed are desired to be the same, this may be accomplished by not connecting “Y” to the integrated furnace control.

If desired for cool, fan and heat to all be the same speed, then “piggyback” jumper “H/C” to “FAN” and do not connect “Y” to the integrated furnace control. Do not connect anything to “H” or “C.”

FIGURE 49
UT Electronic Controls 1028-928
BLOWER OFF TIMINGS

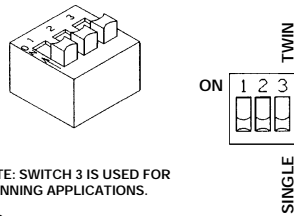

NOTE: SWITCH 3 IS USED FOR TWINNING APPLICATIONS.

1402

OFF TIME	SWITCH 1	SWITCH 2
90 SEC.	OFF	ON
120 SEC.	OFF	OFF
160 SEC.	ON	OFF
180 SEC.	ON	ON

FIGURE 50
UT Electronic Controls 1012-925A
BLOWER OFF TIMINGS

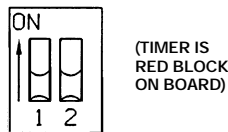

(TIMER IS RED BLOCK ON BOARD)

1335

OFF TIME	SWITCH 1	SWITCH 2
90 SEC.	OFF	ON
120 SEC.	OFF	OFF
160 SEC.	ON	OFF
180 SEC.	ON	ON

FIGURE 51
UT Electronic Controls 1012-925B
BLOWER OFF TIMINGS

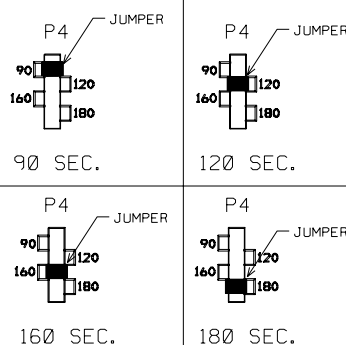

GAS FURNACE (DIRECT DRIVE) INSTRUCTIONS FOR CHANGING BLOWER SPEED

▲ WARNING

DISCONNECT THE ELECTRICAL SUPPLY TO THE FURNACE BEFORE ATTEMPTING TO CHANGE THE BLOWER SPEED. FAILURE TO DO SO CAN CAUSE ELECTRICAL SHOCK RESULTING IN PERSONAL INJURY OR DEATH.

The blower motor is wired for blower speeds required for normal operation as shown.

If additional blower speed taps are available (leads connected to “M1” and “M2” on the electronic control), speeds may be changed if necessary to fit requirements of the particular installation. Reconnect the unused motor leads to “M1” or “M2.” Check motor lead color for speed designation.

Heating speeds should not be reduced where it could cause the furnace air temperature to rise to exceed the maximum outlet air temperature specified for the unit.

IMPORTANT: Always check air temperature rise after changing the heating speed for any reason.

MAINTENANCE

▲ WARNING

THESE INSTRUCTIONS ARE INTENDED AS AN AID TO QUALIFIED SERVICE PERSONNEL FOR PROPER INSTALLATION, ADJUSTMENT AND OPERATION OF THIS UNIT. READ THESE INSTRUCTIONS THOROUGHLY BEFORE ATTEMPTING INSTALLATION OR OPERATION. FAILURE TO FOLLOW THESE INSTRUCTIONS MAY RESULT IN IMPROPER INSTALLATION, ADJUSTMENT, SERVICE OR MAINTENANCE, POSSIBLY RESULTING IN FIRE, ELECTRICAL SHOCK, CARBON MONOXIDE POISONING, EXPLOSION, PROPERTY DAMAGE, PERSONAL INJURY OR DEATH.

DISCONNECT MAIN ELECTRICAL POWER TO THE UNIT BEFORE ATTEMPTING ANY MAINTENANCE. FAILURE TO DO SO CAN CAUSE ELECTRICAL SHOCK RESULTING IN PERSONAL INJURY OR DEATH.

UPFLOW FILTER SIZES				
FURNACE WIDTH	INPUT MBTUH	BOTTOM SIZE	SIDE SIZE	QUANTITY
17½"	45, 60, 75	15¼" X 25"	15¼" X 25"	1
21"	90, 105	19¼" X 25"	15¼" X 25"	1
24½"	120	22¼" X 25"	15¼" X 25"	1
DOWNFLOW FILTER SIZES				
FURNACE WIDTH	INPUT MBTUH	SIZE	QUANTITY	
17½"	45, 60, 75	12" X 20"	2	
21"	90, 105	12" X 20"	2	
24½"	120	14" X 20"	2	

FILTERS

NOTE: (-)GRJ and (-)GTJ models do not come from the factory with filters installed. Filters must be field installed. See Table 9.

Keep the filters clean at all times. Vacuum dirt from filter, wash with detergent and water, air dry thoroughly and reinstall.

Keep the filters clean at all times. Vacuum dirt from filter, wash with detergent and water, air dry thoroughly and reinstall.

NOTE: Some filters must be resized to fit certain units and applications. See Table 10 and Figures 52 and 53.

1. 21" - 90,000 & 105,000 BTUH units require removal of a 3.5-in. segment of filter and frame to get the proper width for a side filter.
2. 24.5" - 120,000 BTUH unit requires removal of a 7" segment of filter and frame to get the proper width for a side filter.

FIGURE 52
BOTTOM PANEL REMOVAL

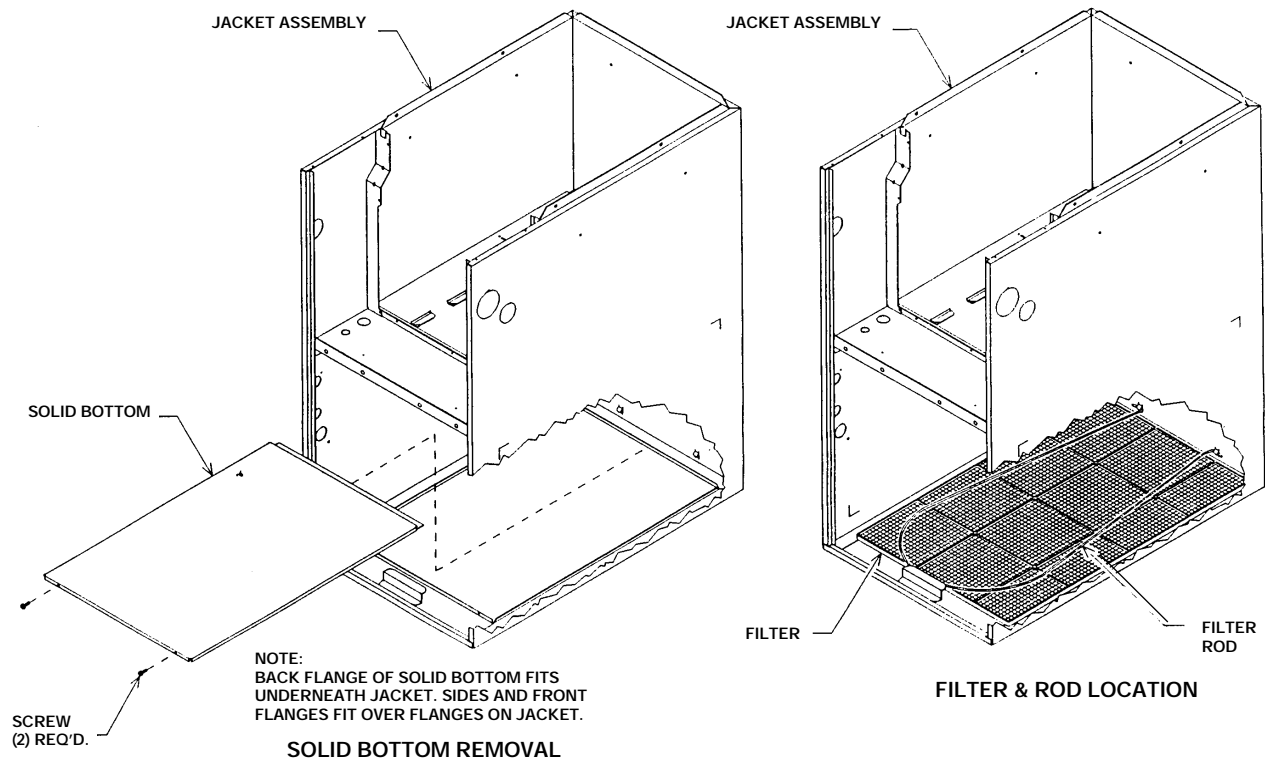
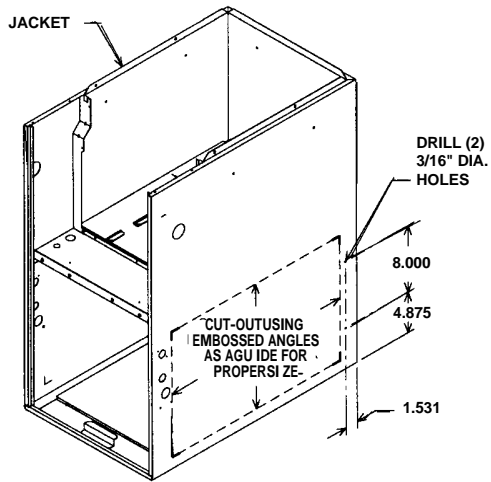
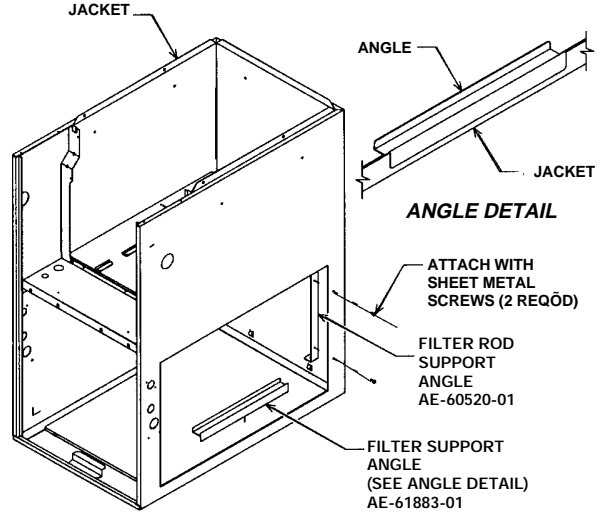

FIGURE 53
FILTER LOCATIONS

UPFLOW



CUT-OUT AND DRILL DETAIL



ROD & FILTER SUPPORT ANGLE ASSEMBLY

DOWNFLOW

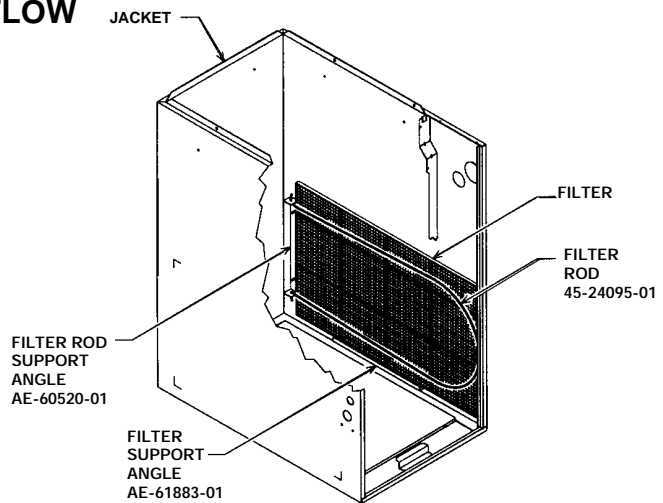
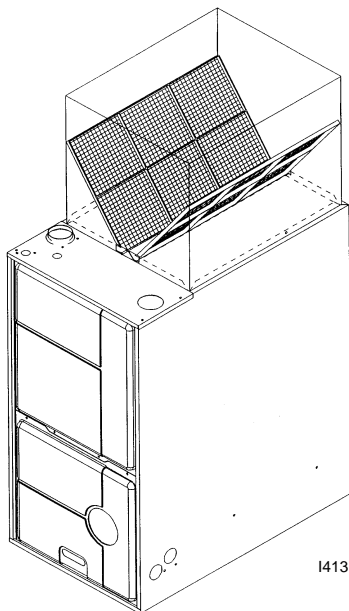

1332

FILTER AND ROD ASSEMBLY

HORIZONTAL

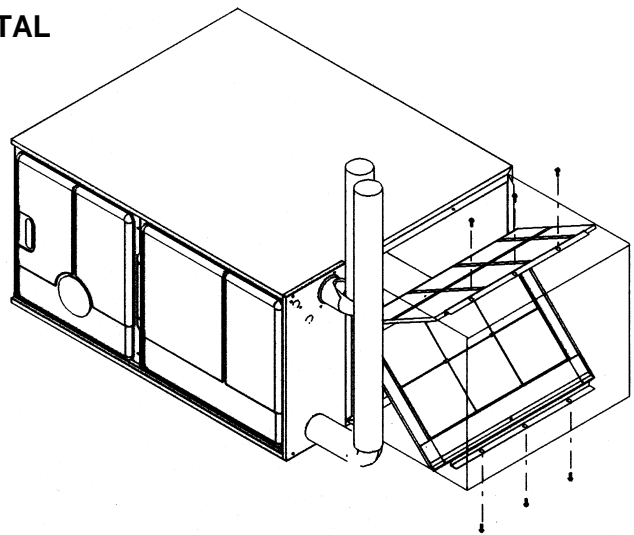
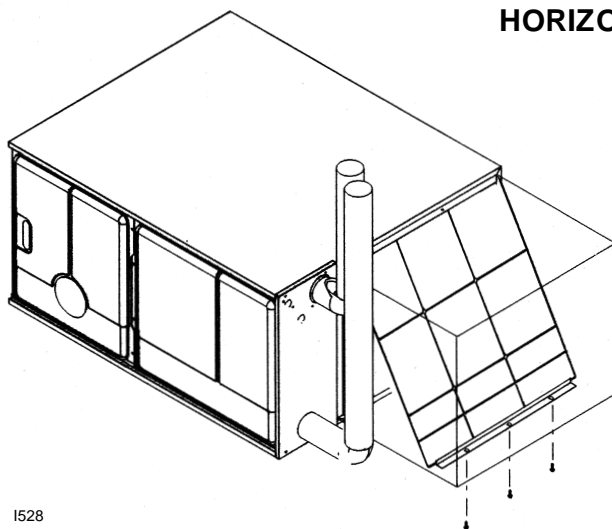

▲ CAUTION

DO NOT OPERATE THE SYSTEM FOR EXTENDED PERIODS WITHOUT FILTERS. A PORTION OF THE DUST ENTRAINED IN THE AIR MAY TEMPORARILY LODGE IN THE AIR DUCT RUNS AND AT THE SUPPLY REGISTERS. ANY RECIRCULATED DUST PARTICLES WILL BE HEATED AND CHARRED BY CONTACT WITH THE FURNACE HEAT EXCHANGER. THIS RESIDUE WILL SOIL CEILINGS, WALLS, DRAPES, CARPETS AND OTHER HOUSEHOLD ARTICLES.

LUBRICATION

IMPORTANT: DO NOT attempt to lubricate the bearings on the blower motor or the induced draft blower motor. Addition of lubricants can reduce the motor life and void the warranty.

The blower motor and induced draft blower motor are permanently lubricated by the manufacturer and do not require further attention.

The blower motor and induced draft blower motor must be cleaned periodically by a qualified installer, service agency, or the gas supplier to prevent the possibility of overheating due to an accumulation of dust and dirt on the windings or on the motor exterior. And, as suggested elsewhere in these instructions, the air filters should be kept clean. Dirty filters can restrict airflow. The motor depends upon sufficient air flowing across and through it to keep from overheating.

SYSTEM OPERATION INFORMATION

Advise The Customer

1. Keep the air filters clean. The heating system will operate better, more efficiently and more economically.
2. Arrange the furniture and drapes so that the supply air registers and the return air grilles are unobstructed.
3. Close doors and windows. This will reduce the heating load on the system.

4. Avoid excessive use of kitchen exhaust fans.
5. Do not permit the heat generated by television, lamps or radios to influence the thermostat operation.
6. Except for the mounting platform, keep all combustible articles 3 feet from the furnace and vent system.
7. **IMPORTANT:** Replace all blower doors and compartment covers after servicing the furnace. Do not operate the unit without all panels and doors securely in place.
8. Explain proper operation of the system with constant air circulation.

ANNUAL INSPECTION

- The furnace should operate for many years without excessive scale build-up in the flue passageways. However, it is recommended that a qualified installer, service agency, or the gas supplier annually inspect the flue passageways, the vent system and the main burners for continued safe operation. Pay particular attention to deterioration from corrosion or other sources.
- **IMPORTANT:** It is recommended that at the beginning and at approximately half way through the heating season, a visual inspection be made of the main burner flames for the desired flame appearance by a qualified installer, service agency or the gas supplier. If the flames are distorted and/or there is evidence of back pressure, check the vent and inlet air system for blockage. If there is carbon and scale in the heat exchanger tubes, the heat exchanger assembly should be replaced.

▲ WARNING

HOLES IN THE VENT PIPE OR HEAT EXCHANGER CAN CAUSE TOXIC FUMES TO ENTER THE HOME, RESULTING IN CARBON MONOXIDE POISONING OR DEATH. THE VENT PIPE OR HEAT EXCHANGER MUST BE REPLACED IF THEY LEAK.

- **IMPORTANT:** It is recommended that at the beginning of the heating season, the flame sensor be cleaned with steel wool by a qualified installer, service agency or the gas supplier.
- **IMPORTANT:** It is recommended that at the beginning of the heating season, the condensate trap be inspected for debris or blockage. A blocked condensate trap can cause water to back up into the primary heat exchanger and lead to nuisance tripping of the overtemperature switches.
- **IMPORTANT:** It is recommended that at the beginning of the heating season, the condensate neutralizer if used be replaced by a qualified installer, service agency or the gas supplier.
- **IMPORTANT:** It is recommended that an annual inspection and cleaning of all furnace markings be made to assure legibility. Attach a replacement marking, which can be obtained through the distributor, if any are found to be illegible or missing.

REPLACEMENT PARTS

See sheet enclosed with furnace for replacement part information.

TROUBLESHOOTING

Refer to Figures 54 and 55 for determining cause of unit problems.

WIRING DIAGRAMS

Figures 56 through 59 are complete wiring diagrams for the furnace and power sources.

FIGURE 54

(-)GRA/(-)GRJ MODELS W/INTEGRATED FURNACE CONTROL (IFC) UT Electronic Controls 1012-925 (115 VAC IGNITER)

WARNING

DISCONNECT POWER BEFORE SERVICING.
SERVICE MUST BE BY A TRAINED, QUALIFIED SERVICE TECHNICIAN.

HAZARDOUS VOLTAGE
LINE VOLTAGE
CONNECTIONS

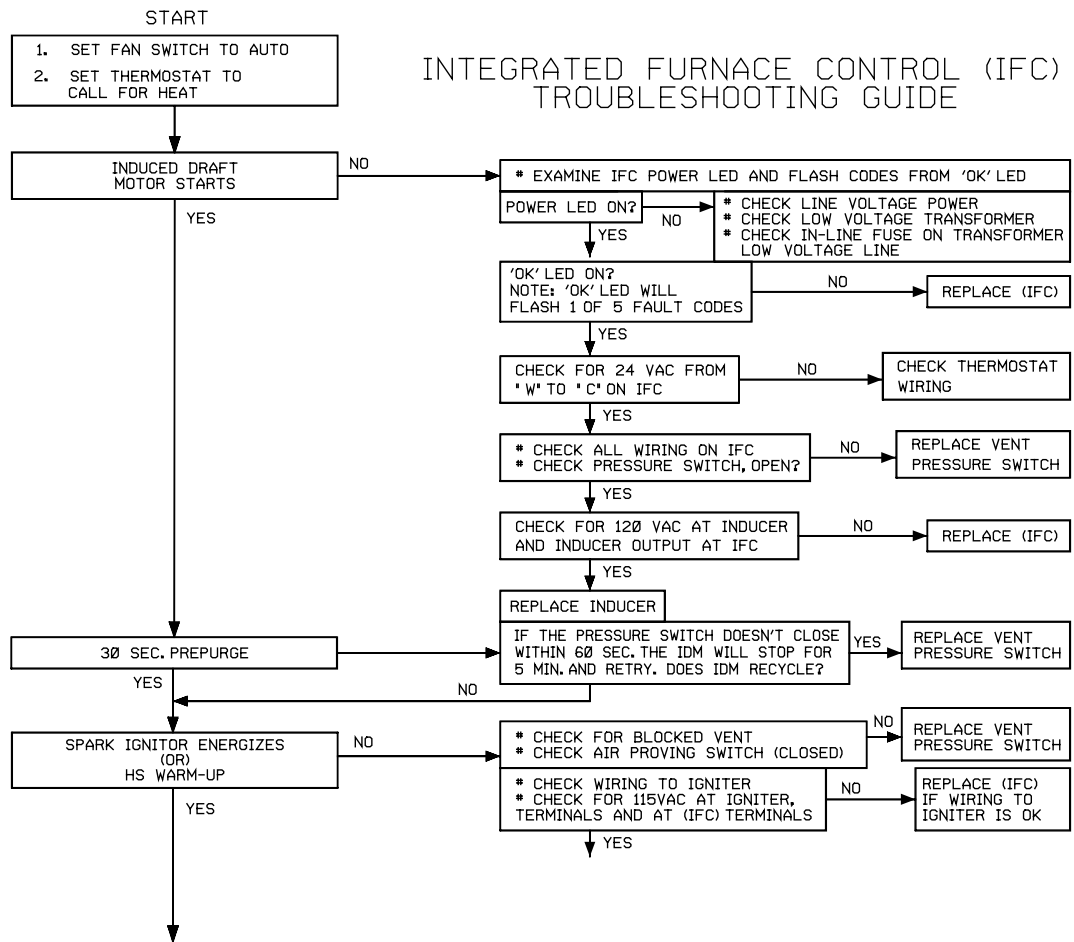
NOTE:
 STATIC DISCHARGE CAN DAMAGE INTEGRATED FURNACE CONTROL (IFC)

* "OK" LED BLINKS TO INDICATE EXTERNAL FAULTS:

- (1) BLINK FOLLOWED BY A 2 SEC. PAUSE - 1 HOUR LOCKOUT
- (2) BLINKS FOLLOWED BY A 2 SEC. PAUSE - PRESSURE SWITCH IS OPEN
- (3) BLINKS FOLLOWED BY A 2 SEC. PAUSE - LIMIT SWITCH IS OPEN
- (4) BLINKS FOLLOWED BY A 2 SEC. PAUSE - PRESSURE SWITCH CLOSED

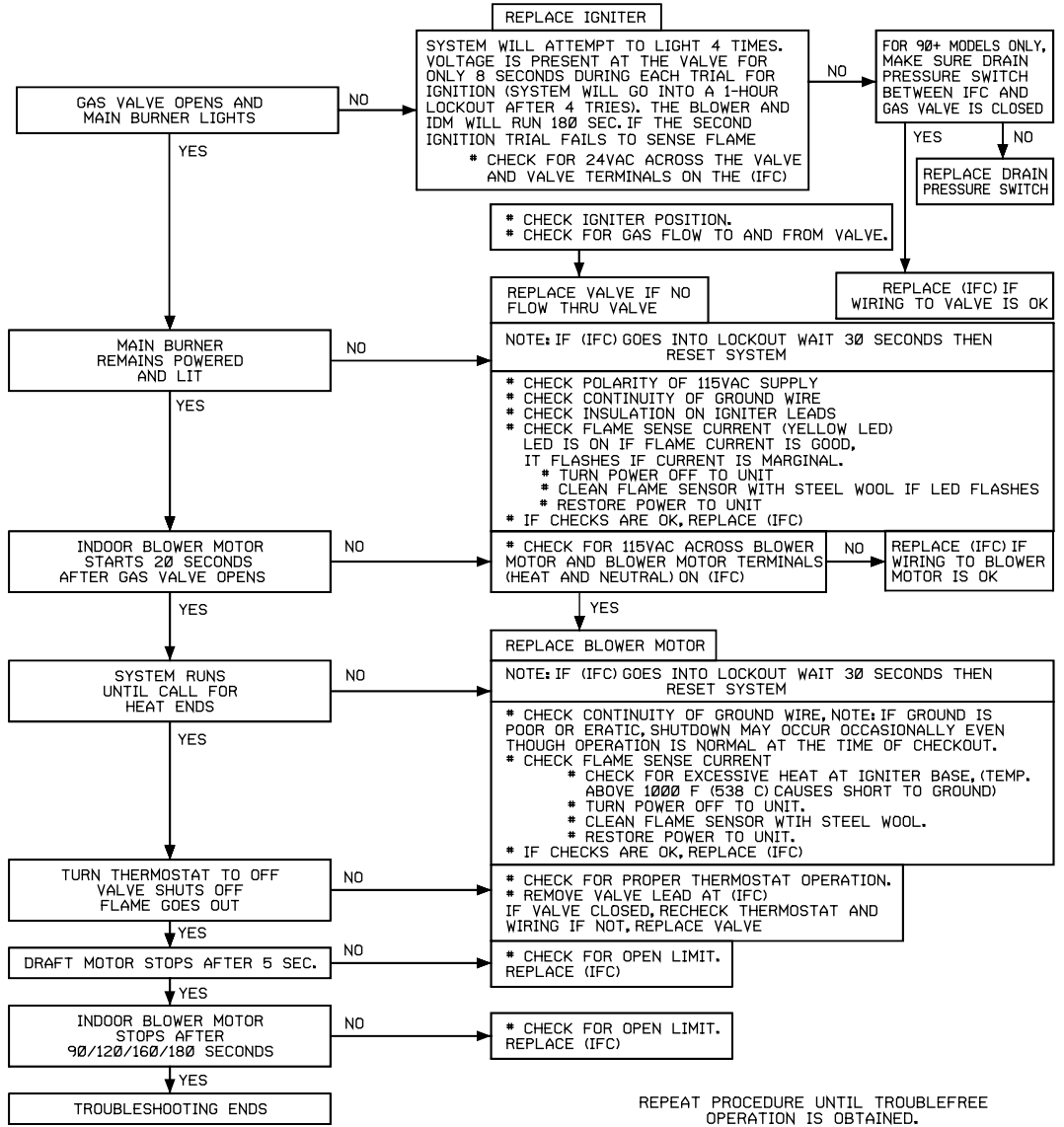

REPEAT PROCEDURE UNTIL TROUBLEFREE OPERATION IS OBTAINED.

92-22744-10-03

FIGURE 55

(-)GTA/(-)GTJ MODELS W/INTEGRATED FURNACE CONTROL (IFC) UT Electronic Controls 1012-925

WARNING

DISCONNECT POWER BEFORE SERVICING.
 SERVICE MUST BE BY A TRAINED, QUALIFIED
 SERVICE TECHNICIAN.
 HAZARDOUS VOLTAGE
 LINE VOLTAGE
 CONNECTIONS



INTEGRATED FURNACE CONTROL (IFC)
TROUBLESHOOTING GUIDE

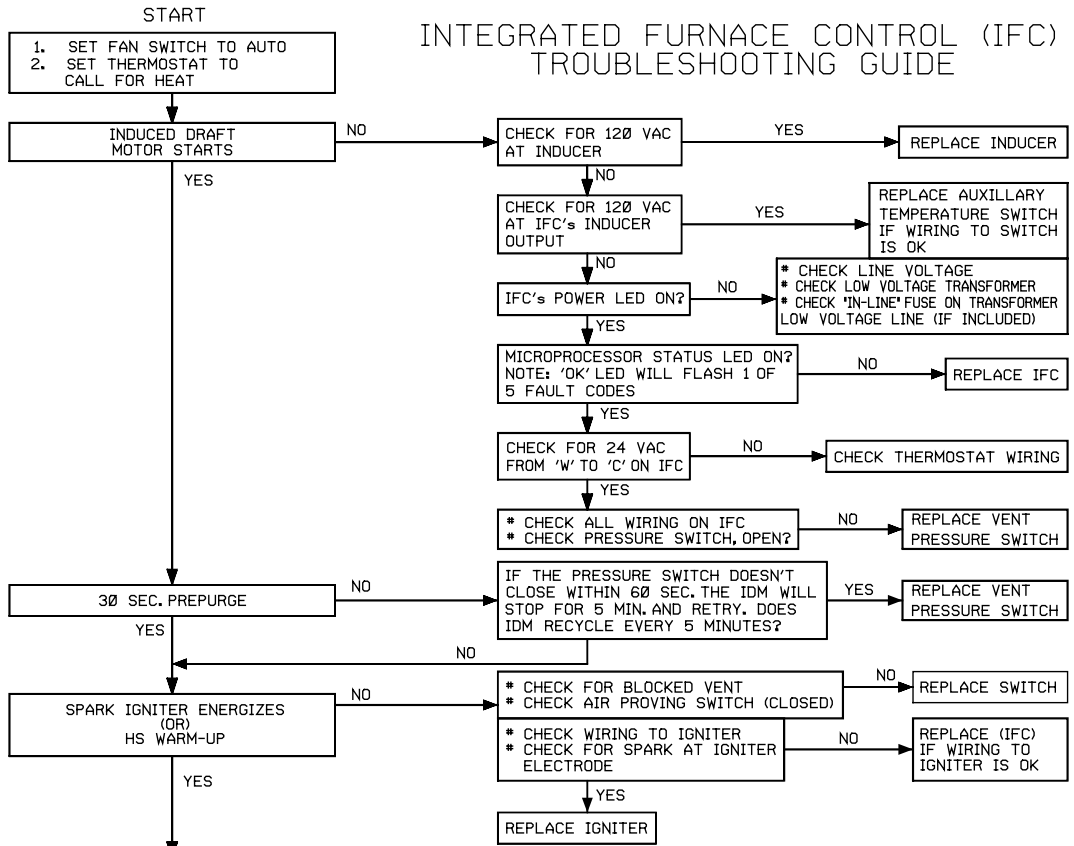

CONTINUED ON NEXT PAGE

NOTE:
 STATIC DISCHARGE CAN DAMAGE INTEGRATED FURNACE CONTROL (IFC)

* "OK" LED BLINKS TO INDICATE EXTERNAL FAULTS:
 (1) BLINK FOLLOWED BY A 2 SEC. PAUSE - 1 HOUR LOCKOUT
 (2) BLINKS FOLLOWED BY A 2 SEC. PAUSE - PRESSURE SWITCH IS OPEN
 (3) BLINKS FOLLOWED BY A 2 SEC. PAUSE - LIMIT SWITCH IS OPEN
 (4) BLINKS FOLLOWED BY A 2 SEC. PAUSE - PRESSURE SWITCH CLOSED
 (5) TWINNING FAULT

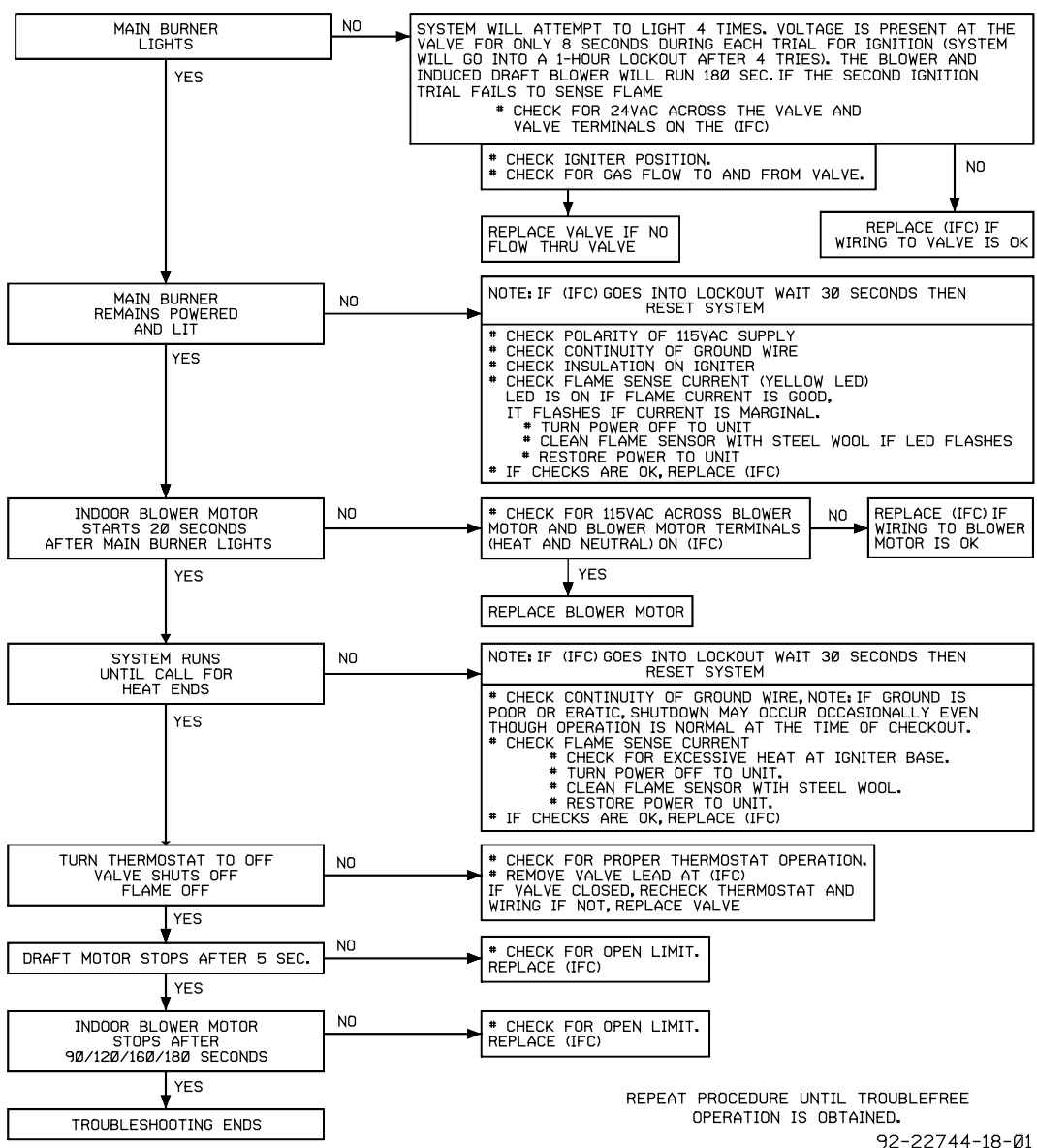

REPEAT PROCEDURE UNTIL TROUBLEFREE OPERATION IS OBTAINED.
 92-22744-18-01

FIGURE 56
 (-)GRA MODELS WITH UT ELECTRONIC CONTROLS 1028-928 & SPARK IGNITION

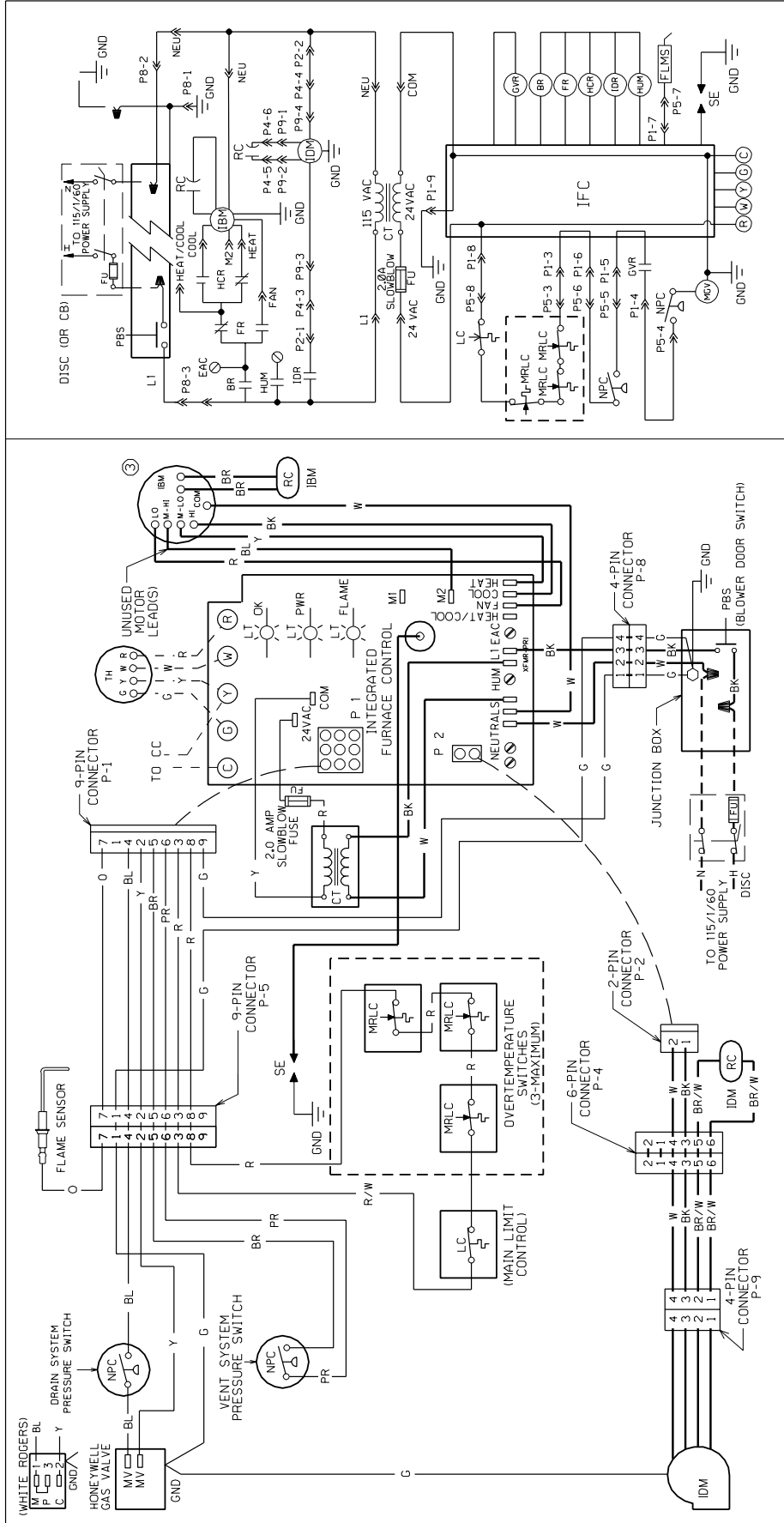

<p>COMPONENT CODE</p> <p>AUX LIMIT CONTROL (TEMP) BLOWER RELAY CC COMPRESSOR CONTACTOR CT CONTROL TRANSFORMER DISC DISCONNECT SWITCH EAC ELECTRIC AIR CLEANER FR FAN RELAY FLS FLAME SENSOR FU FUSE GND GROUND GVR GAS VALVE RELAY HCR HEAT/COOL RELAY HUM HUMIDIFIER RELAY IBM INDOOR BLOWER MOTOR IDM INDUCED DRAFT MOTOR IDR INDUCED DRAFT RELAY</p>	<p>NOTES:</p> <p>① IF FACTORY WIRING OF HEATING AND COOLING SPEEDS IS NOT DESIRABLE, REFER TO SPEC. SHEET FOR APPROPRIATE SPEEDS.</p> <p>② CONNECT UNUSED MOTOR LEADS TO M1 AND/OR M2.</p> <p>③ MODELS WITH 3 SPEED MOTOR - BLUE LEAD IS FOR MEDIUM SPEED NO YELLOW LEAD ON MOTOR</p>	<p>WIRING INFORMATION</p> <p>LINE VOLTAGE -FACTORY STANDARD -FIELD INSTALLED</p> <p>LOW VOLTAGE -FACTORY STANDARD -FIELD INSTALLED</p> <p>REPLACEMENT WIRE -MUST BE THE SAME SIZE AND TYPE OF INSULATION AS ORIGINAL (105 C MIN.)</p> <p>WARNING -CABINET MUST BE PERMANENTLY GROUNDED AND CONFORM TO I.E.C., C.E.C. AND LOCAL CODES AS APPLICABLE.</p>	<p>WIRE COLOR CODE</p> <p>BK --- BLACK BR --- BROWN BL --- BLUE G --- GREEN W --- WHITE Y --- YELLOW</p> <p>ELECTRICAL WIRING DIAGRAM</p> <p>UPFLOW BLOWER INDUCED DRAFT GAS FIRED, FORCED AIR FURNACE SINGLE STAGE HEAT SINGLE STAGE COOL DIRECT SPARK IGNITION</p>
<p>DWG. NO. 90-24007-04</p>	<p>DR. BY JIM</p>	<p>DATE 7-11-96</p>	<p>DWG. NO. 90-24007-04</p> <p>REV 04</p>

FIGURE 57
 (-)GTA MODELS WITH UT ELECTRONIC CONTROLS 1028-928 & SPARK IGNITION

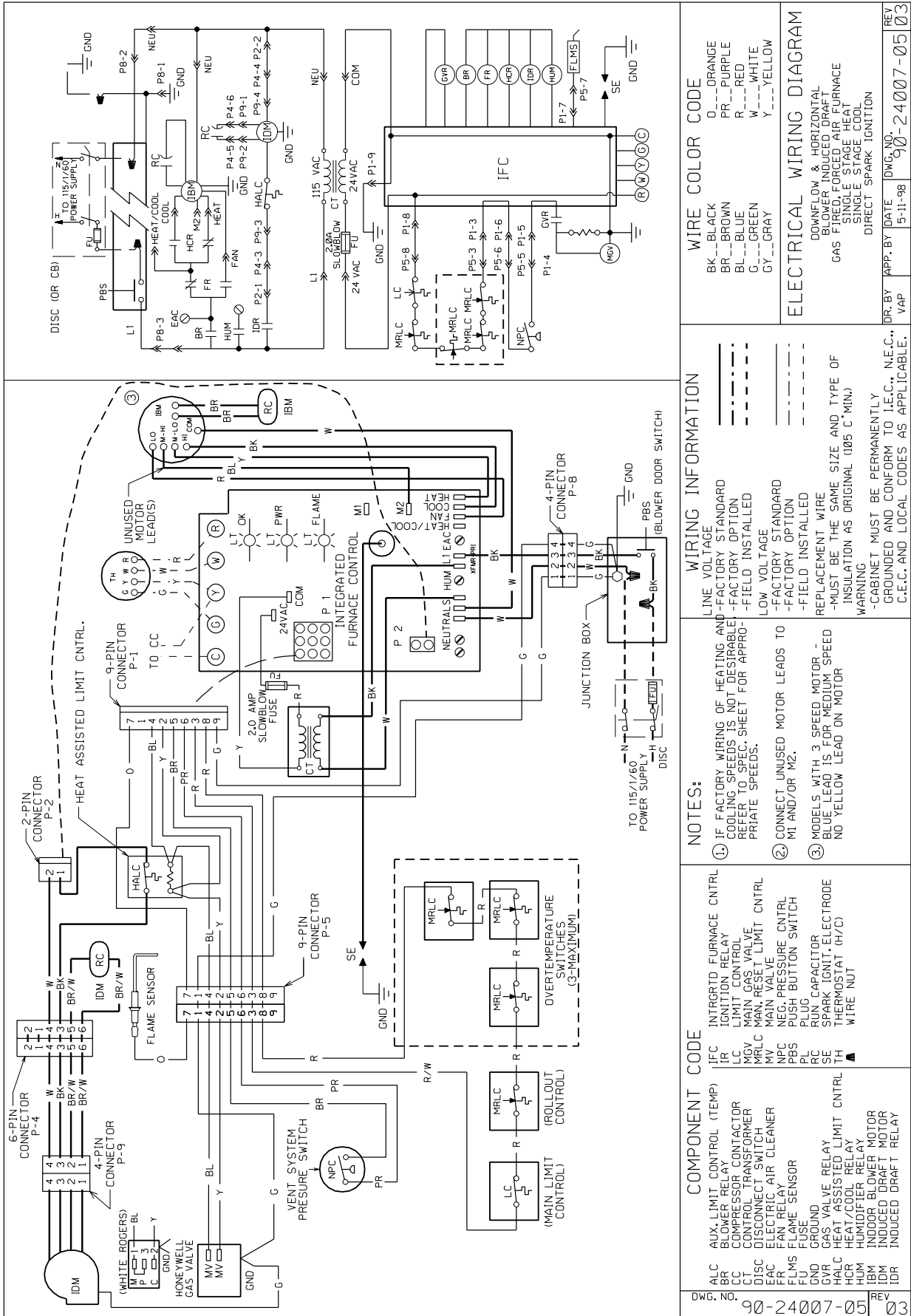

WIRE COLOR CODE	
ORANGE	O
PURPLE	PR
RED	R
WHITE	W
YELLOW	Y
BLACK	BK
BROWN	BR
BLUE	BL
GREEN	G
GRAY	GY

ELECTRICAL WIRING DIAGRAM	
DOWNFLOW & HORIZONTAL BLOWER INDUCED DRAFT	IFC
GAS FIRED, FORCED AIR FURNACE	IBM
SINGLE STAGE HEAT INSULATION AS ORIGINAL (105° C MIN)	IBM
WARNING	IBM
-CABINET MUST BE PERMANENTLY GROUNDED AND CONFORM TO I.E.C., N.E.C., C.E.C. AND LOCAL CODES AS APPLICABLE.	IBM

NOTES:	
① IF FACTORY WIRING OF HEATING AND COOLING SPEEDS IS NOT DESIRABLE REFER TO SPEC. SHEET FOR APPROPRIATE SPEEDS.	①
② CONNECT UNUSED MOTOR LEADS TO M1 AND/OR M2.	②
③ MODELS WITH 3 SPEED MOTOR - BLUE LEAD IS FOR MEDIUM SPEED NO YELLOW LEAD ON MOTOR	③

WIRING INFORMATION	
LINE VOLTAGE	---
-FACTORY STANDARD	---
-FIELD INSTALLED	---
LOW VOLTAGE	---
-FACTORY STANDARD	---
-FIELD INSTALLED	---

COMPONENT CODE	
AUX. LIMIT CONTROL (TEMP)	LC
BLOWER RELAY CONTACTOR	BR
COMPRESSOR	C
CONTROL TRANSFORMER	CT
DISCONNECT SWITCH	DISC
ELECTRIC AIR CLEANER	EAC
FAN RELAY	FR
FAN FLAME SENSOR	FFLS
FUSE	FU
GROUND	GND
GAS VALVE RELAY	GVR
HEAT ASSISTED LIMIT CNTRL	HALC
HEAT/COOL RELAY	HCR
HUMIDIFIER RELAY	HUM
INDOOR BLOWER MOTOR	IBM
INDUCED DRAFT MOTOR	IDR
INDUCED DRAFT RELAY	IDR
INTEGRATED FURNACE CNTRL	IFC
IGNITION RELAY	IR
IGNITION CONTROL	ICV
MAIN GAS VALVE	MV
MAIN RESET LIMIT CNTRL	MRLC
NEG. PRESSURE CNTRL	NPC
PUSH BUTTON SWITCH	PBS
PLUG	PLUG
RUN CAPACITOR	RC
SPARK IGNIT. ELECTRODE	SE
THERMOSTAT (H/C)	TH
WIRE NUT	▲

DWG. NO.	90-24007-05	REV	03
----------	-------------	-----	----

FIGURE 58
 (-)GRJ MODELS WITH UT ELECTRONIC CONTROLS 1012-925 CONTROL BOARD & HSI

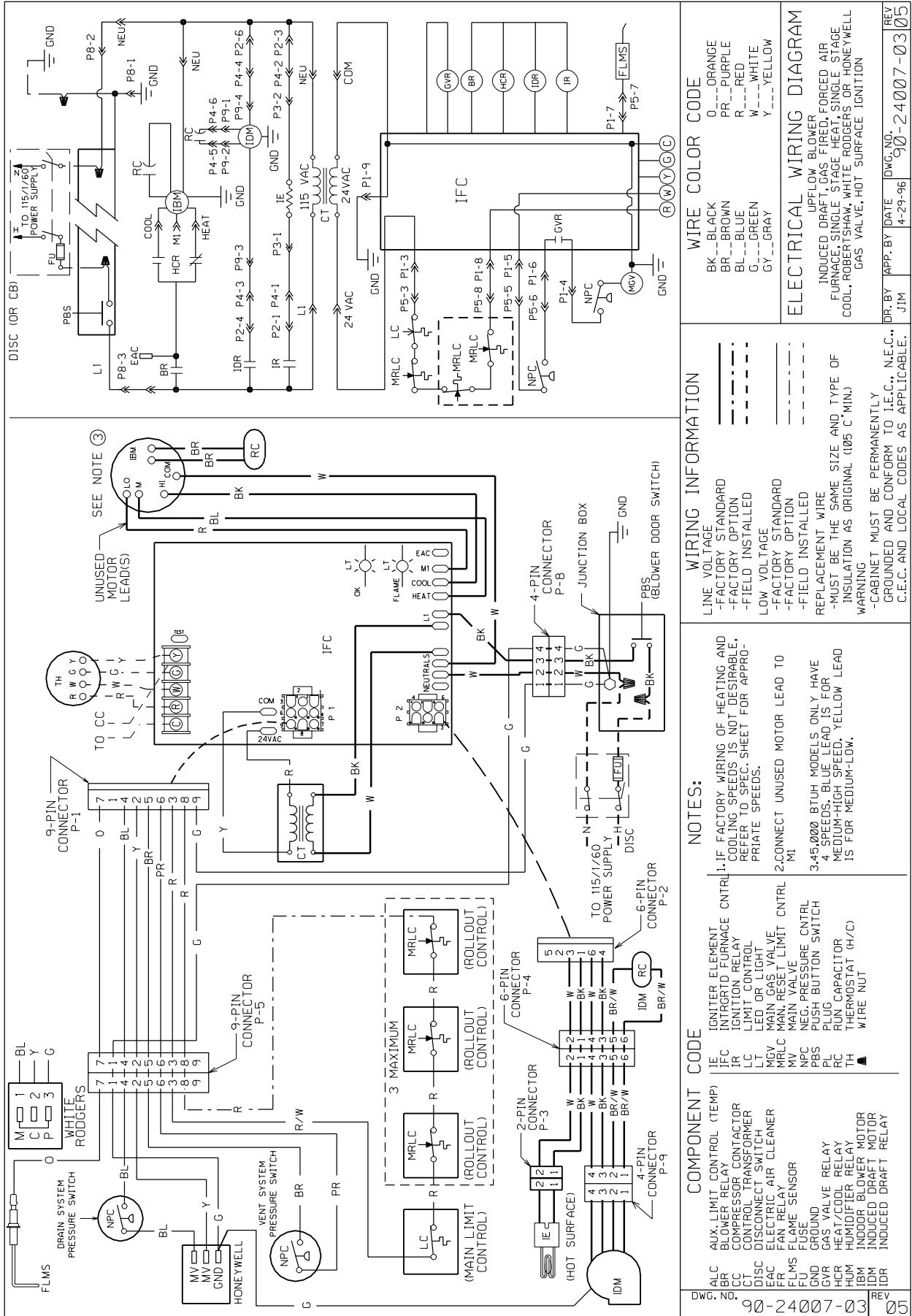
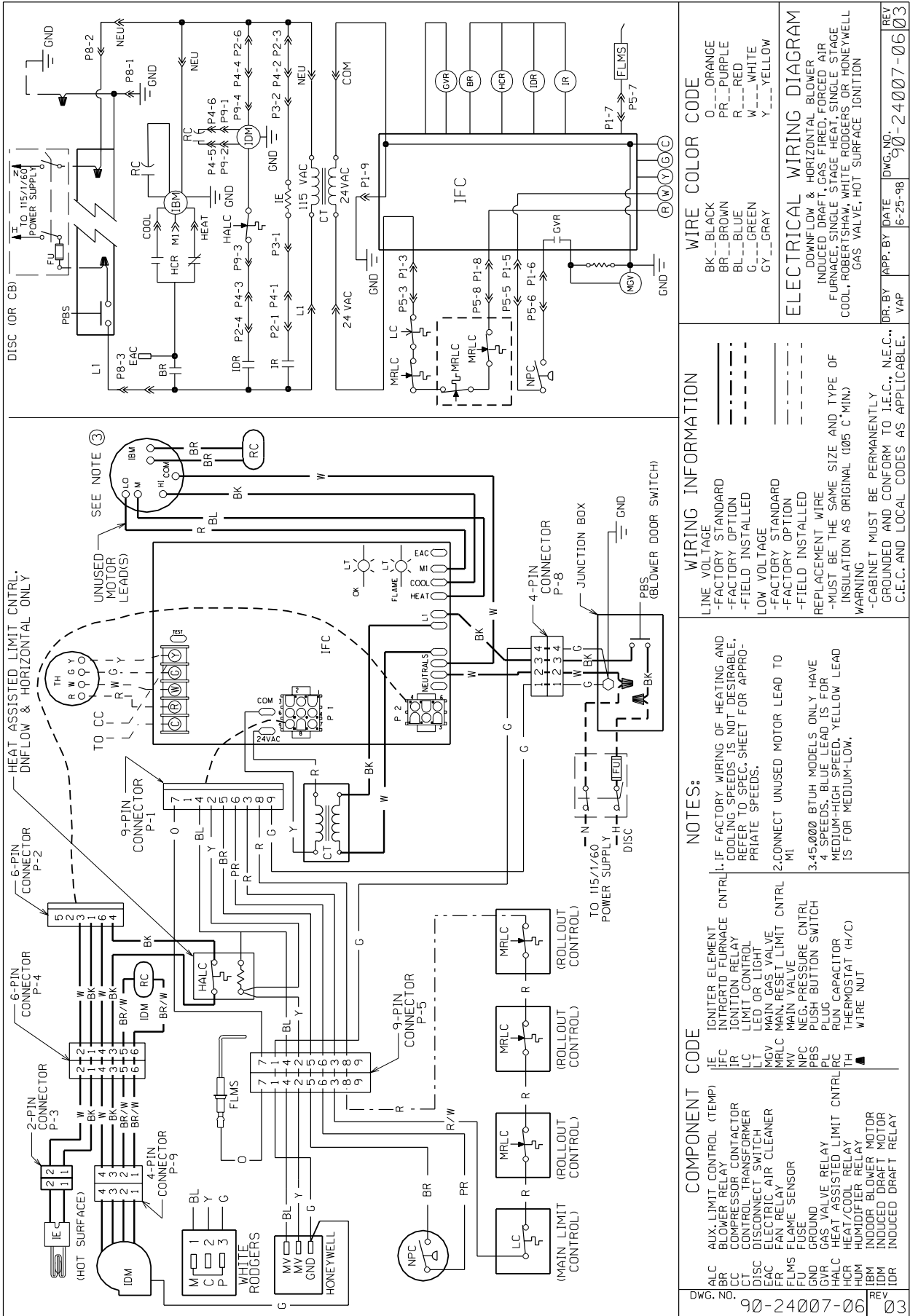

FIGURE 59
 (-)GTJ MODELS WITH UT ELECTRONIC CONTROLS 1012-925 CONTROL BOARD & HSI



WIRE COLOR CODE

BK	BLACK
BR	BROWN
BL	BLUE
G	GREEN
GY	GRAY
OR	ORANGE
PR	PURPLE
R	RED
W	WHITE
Y	YELLOW

ELECTRICAL WIRING DIAGRAM
 DOWNFLOW & HORIZONTAL BLOWER
 INDUCED DRAFT, GAS FIRED, FORCED AIR
 FURNACE SINGLE STAGE HEAT, SINGLE STAGE
 COOL, ROBERTSHAW, WHITE RODGERS OR HONEYWELL
 GAS VALVE, HOT SURFACE IGNITION

WIRING INFORMATION

LINE VOLTAGE
 -FACTORY STANDARD
 -FACTORY OPTION
 -FIELD INSTALLED

LOW VOLTAGE
 -FACTORY STANDARD
 -FACTORY OPTION
 -FIELD INSTALLED

REPLACEMENT WIRE
 -MUST BE THE SAME SIZE AND TYPE OF
 INSULATION AS ORIGINAL (105 C MIN.)

WARNING
 -CABINET MUST BE PERMANENTLY
 GROUNDED AND CONFORM TO I.E.C., N.E.C.,
 C.E.C. AND LOCAL CODES AS APPLICABLE.

NOTES:

1. IF FACTORY WIRING OF HEATING AND COOLING SPEEDS IS NOT DESIRABLE, REFER TO SPEC. SHEET FOR APPROPRIATE SPEEDS.

2. CONNECT UNUSED MOTOR LEAD TO MI

3. 45.000 BTUH MODELS ONLY HAVE 4 SPEEDS. BLUE LEAD IS FOR MEDIUM-HIGH SPEED, YELLOW LEAD IS FOR MEDIUM-LOW.

COMPONENT CODE

IE	IGNITER ELEMENT
IFC	INTRGRD FURNACE CNTRL
IR	IGNITION RELAY
LC	LIMIT CONTROL
LED	LED OR LIGHT
MV	MAIN GAS VALVE
MRLC	MAIN RESETE LIMIT CNTRL
MRC	MAIN VALVE
NPC	NEG. PRESSURE CNTRL
PBS	PUSH BUTTON SWITCH
PLC	PLUG CAPACITOR
TH	THERMOSTAT (H/C)
W	WIRE NUT
ALC	AUX. LIMIT CONTROL (TEMP)
BM	BLOWER RELAY
CC	COMPRESSOR CONTACTOR
CT	CONTROL TRANSFORMER
DISC	DISCONNECT SWITCH
EAC	ELECTRIC AIR CLEANER
FLMS	FAN RELAY
FUE	FUE SENSOR
GND	GROUND
GVR	GAS VALVE RELAY
HALC	HEAT ASSISTED LIMIT CNTRL
HCR	HEAT/COOL RELAY
HUM	HUMIDIFIER RELAY
IDM	INDOOR BLOWER MOTOR
IBM	INDUCED DRAFT MOTOR
IDR	INDUCED DRAFT RELAY

DR. BY	APP. BY	DATE	DWG. NO.	REV
		6-25-98	90-24007-06	03

NOTES