

# INSTALLATION INSTRUCTIONS

## PACKAGE HEAT PUMPS FEATURING INDUSTRY STANDARD R-410A REFRIGERANT <sup>R-410A</sup>

RQNL- 13 SEER SERIES (2-4 TONS)

RQPL- 14 SEER SERIES (2-4 TONS)



14 SEER ONLY



**RECOGNIZE THIS SYMBOL AS AN INDICATION OF IMPORTANT SAFETY INFORMATION!**

### **▲ WARNING**

THESE INSTRUCTIONS ARE INTENDED AS AN AID TO QUALIFIED, LICENSED SERVICE PERSONNEL FOR PROPER INSTALLATION, ADJUSTMENT AND OPERATION OF THIS UNIT. READ THESE INSTRUCTIONS THOROUGHLY BEFORE ATTEMPTING INSTALLATION OR OPERATION. FAILURE TO FOLLOW THESE INSTRUCTIONS MAY RESULT IN IMPROPER INSTALLATION, ADJUSTMENT, SERVICE OR MAINTENANCE POSSIBLY RESULTING IN FIRE, ELECTRICAL SHOCK, PROPERTY DAMAGE, PERSONAL INJURY OR DEATH.



**DO NOT DESTROY THIS MANUAL**  
**PLEASE READ CAREFULLY AND KEEP IN A SAFE PLACE FOR FUTURE REFERENCE BY A SERVICEMAN**



# TABLE OF CONTENTS

I. Safety Information .....	3
II. Introduction .....	5
A. R-410A Refrigerant .....	5
1. Specification of R-410A.....	5
2. Quick Reference for R-410A.....	5
3. Evaporator Coil/TXV .....	5
4. Tools Required for Installing and Servicing R-410A Models.....	5
III. Checking Product Received.....	8
IV. Equipment Protection.....	8
V. Installation .....	8
A. General .....	8
1. Pre-Installation Check Points .....	8
2. Location.....	8
B. Outside Slab Installation.....	10
C. Clearances .....	10
D. Rooftop Installation.....	10
VI. Ductwork .....	11
VII. Filters .....	12
VIII. Conversion Procedure .....	13
IX. Condensate Drain .....	13
X. Condensate Drain, Outdoor Coil.....	14
XI. Electrical Wiring .....	14
A. Power Wiring.....	14
B. Control Wiring .....	14
C. Internal Wiring.....	14
D. Grounding .....	14
E. Thermostat.....	15
XII. Indoor Air Flow Data .....	16
XIII. Crankcase Heat .....	16
XIV. Pre-Start Check.....	16
XV. Startup.....	16
XVI. Operation .....	17
XVII. Auxiliary Heat .....	17
XVIII. Demand Defrost Control and High/Low Pressure Controls.....	18
XIX. General Data.....	20-24
XX. Miscellaneous	
Electrical Data .....	25-26
Airflow Performance .....	27-30
Heater Kit Characteristics.....	31-32
Wiring Diagrams.....	33-37
Charge Charts .....	38-42
Trouble Shooting .....	43

# I. SAFETY INFORMATION

## WARNING

**IMPORTANT: ALL MANUFACTURER PRODUCTS MEET CURRENT FEDERAL OSHA GUIDELINES FOR SAFETY. CALIFORNIA PROPOSITION 65 WARNINGS ARE REQUIRED FOR CERTAIN PRODUCTS, WHICH ARE NOT COVERED BY THE OSHA STANDARDS.**

**CALIFORNIA'S PROPOSITION 65 REQUIRES WARNINGS FOR PRODUCTS SOLD IN CALIFORNIA THAT CONTAIN, OR PRODUCE, ANY OF OVER 600 LISTED CHEMICALS KNOWN TO THE STATE OF CALIFORNIA TO CAUSE CANCER OR BIRTH DEFECTS SUCH AS FIBERGLASS INSULATION, LEAD IN BRASS, AND COMBUSTION PRODUCTS FROM NATURAL GAS.**

**ALL "NEW EQUIPMENT" SHIPPED FOR SALE IN CALIFORNIA WILL HAVE LABELS STATING THAT THE PRODUCT CONTAINS AND/OR PRODUCES PROPOSITION 65 CHEMICALS. ALTHOUGH WE HAVE NOT CHANGED OUR PROCESSES, HAVING THE SAME LABEL ON ALL OUR PRODUCTS FACILITATES MANUFACTURING AND SHIPPING. WE CANNOT ALWAYS KNOW "WHEN, OR IF" PRODUCTS WILL BE SOLD IN THE CALIFORNIA MARKET.**

**YOU MAY RECEIVE INQUIRIES FROM CUSTOMERS ABOUT CHEMICALS FOUND IN, OR PRODUCED BY, SOME OF OUR HEATING AND AIR-CONDITIONING EQUIPMENT, OR FOUND IN NATURAL GAS USED WITH SOME OF OUR PRODUCTS. LISTED BELOW ARE THOSE CHEMICALS AND SUBSTANCES COMMONLY ASSOCIATED WITH SIMILAR EQUIPMENT IN OUR INDUSTRY AND OTHER MANUFACTURERS.**

- GLASS WOOL (FIBERGLASS) INSULATION
- CARBON MONOXIDE (CO)
- FORMALDEHYDE
- BENZENE

**MORE DETAILS ARE AVAILABLE AT THE WEBSITES FOR OSHA (OCCUPATIONAL SAFETY AND HEALTH ADMINISTRATION), AT [WWW.OSHA.GOV](http://WWW.OSHA.GOV) AND THE STATE OF CALIFORNIA'S OEHHA (OFFICE OF ENVIRONMENTAL HEALTH HAZARD ASSESSMENT), AT [WWW.OEHHA.ORG](http://WWW.OEHHA.ORG). CONSUMER EDUCATION IS IMPORTANT SINCE THE CHEMICALS AND SUBSTANCES ON THE LIST ARE FOUND IN OUR DAILY LIVES. MOST CONSUMERS ARE AWARE THAT PRODUCTS PRESENT SAFETY AND HEALTH RISKS, WHEN IMPROPERLY USED, HANDLED AND MAINTAINED.**

## WARNING

**THE MANUFACTURER'S WARRANTY DOES NOT COVER ANY DAMAGE OR DEFECT TO THE HEAT PUMP CAUSED BY THE ATTACHMENT OR USE OF ANY COMPONENTS, ACCESSORIES OR DEVICES (OTHER THAN THOSE AUTHORIZED BY THE MANUFACTURER) INTO, ONTO OR IN CONJUNCTION WITH THE HEAT PUMP. YOU SHOULD BE AWARE THAT THE USE OF UNAUTHORIZED COMPONENTS, ACCESSORIES OR DEVICES MAY ADVERSELY AFFECT THE OPERATION OF THE HEAT PUMP AND MAY ALSO ENDANGER LIFE AND PROPERTY. THE MANUFACTURER DISCLAIMS ANY RESPONSIBILITY FOR SUCH LOSS OR INJURY RESULTING FROM THE USE OF SUCH UNAUTHORIZED COMPONENTS, ACCESSORIES OR DEVICES.**

## WARNING

**DISCONNECT ALL POWER TO THE UNIT BEFORE STARTING MAINTENANCE. FAILURE TO DO SO CAN RESULT IN SEVERE ELECTRICAL SHOCK OR DEATH.**

## WARNING


**DO NOT, UNDER ANY CIRCUMSTANCES, CONNECT RETURN DUCTWORK TO ANY OTHER HEAT PRODUCING DEVICE SUCH AS A FIREPLACE INSERT, STOVE, ETC. UNAUTHORIZED USE OF SUCH DEVICES MAY RESULT IN FIRE, CARBON MONOXIDE POISONING, EXPLOSION, PROPERTY DAMAGE,**

** WARNING**

**THE UNIT MUST BE PERMANENTLY GROUNDED. A GROUNDING LUG IS PROVIDED IN THE ELECTRIC HEAT KIT FOR A GROUND WIRE. (SEE FIGURE 10.) FAILURE TO GROUND THIS UNIT CAN RESULT IN FIRE OR ELECTRICAL SHOCK CAUSING PROPERTY DAMAGE, SEVERE PERSONAL INJURY OR**

** WARNING**

**ONLY ELECTRIC HEATER KITS SUPPLIED BY THIS MANUFACTURER AS DESCRIBED IN THIS PUBLICATION HAVE BEEN DESIGNED, TESTED, AND EVALUATED BY A NATIONALLY RECOGNIZED SAFETY TESTING AGENCY FOR USE WITH THIS UNIT. USE OF ANY OTHER MANUFACTURED ELECTRIC HEATERS INSTALLED WITHIN THIS UNIT MAY CAUSE HAZARDOUS CONDITIONS RESULTING IN PROPERTY DAMAGE, FIRE, BODILY INJURY OR DEATH.**

 Recognize this symbol as an indication of Important Safety Information!

## WARNING

**IMPORTANT: ALL MANUFACTURER PRODUCTS MEET CURRENT FEDERAL OSHA GUIDELINES FOR SAFETY. CALIFORNIA PROPOSITION 65 WARNINGS ARE REQUIRED FOR CERTAIN PRODUCTS, WHICH ARE NOT COVERED BY THE OSHA STANDARDS.**

**CALIFORNIA'S PROPOSITION 65 REQUIRES WARNINGS FOR PRODUCTS SOLD IN CALIFORNIA THAT CONTAIN, OR PRODUCE, ANY OF OVER 600 LISTED CHEMICALS KNOWN TO THE STATE OF CALIFORNIA TO CAUSE CANCER OR BIRTH DEFECTS SUCH AS FIBERGLASS INSULATION, LEAD IN BRASS, AND COMBUSTION PRODUCTS FROM NATURAL GAS.**

**ALL "NEW EQUIPMENT" SHIPPED FOR SALE IN CALIFORNIA WILL HAVE LABELS STATING THAT THE PRODUCT CONTAINS AND/OR PRODUCES PROPOSITION 65 CHEMICALS. ALTHOUGH WE HAVE NOT CHANGED OUR PROCESSES, HAVING THE SAME LABEL ON ALL OUR PRODUCTS FACILITATES MANUFACTURING AND SHIPPING. WE CANNOT ALWAYS KNOW "WHEN, OR IF" PRODUCTS WILL BE SOLD IN THE CALIFORNIA MARKET.**

**YOU MAY RECEIVE INQUIRIES FROM CUSTOMERS ABOUT CHEMICALS FOUND IN, OR PRODUCED BY, SOME OF OUR HEATING AND AIR-CONDITIONING EQUIPMENT, OR FOUND IN NATURAL GAS USED WITH SOME OF OUR PRODUCTS. LISTED BELOW ARE THOSE CHEMICALS AND SUBSTANCES COMMONLY ASSOCIATED WITH SIMILAR EQUIPMENT IN OUR INDUSTRY AND OTHER MANUFACTURERS.**

- GLASS WOOL (FIBERGLASS) INSULATION
- CARBON MONOXIDE (CO)
- FORMALDEHYDE
- BENZENE

**MORE DETAILS ARE AVAILABLE AT THE WEBSITES FOR OSHA (OCCUPATIONAL SAFETY AND HEALTH ADMINISTRATION), AT [WWW.OSHA.GOV](http://WWW.OSHA.GOV) AND THE STATE OF CALIFORNIA'S OEHHA (OFFICE OF ENVIRONMENTAL HEALTH HAZARD ASSESSMENT), AT [WWW.OEHHA.ORG](http://WWW.OEHHA.ORG). CONSUMER EDUCATION IS IMPORTANT SINCE THE CHEMICALS AND SUBSTANCES ON THE LIST ARE FOUND IN OUR DAILY LIVES. MOST CONSUMERS ARE AWARE THAT PRODUCTS PRESENT SAFETY AND HEALTH RISKS, WHEN IMPROPERLY USED, HANDLED AND MAINTAINED.**

## II. INTRODUCTION

This booklet contains the installation and operating instructions for your package heat pump. There are a few precautions that should be taken to derive maximum satisfaction from it. Improper installation can result in unsatisfactory operation or dangerous conditions.

Read this booklet and any instructions packaged with separate equipment required to make up the system prior to installation. Give this booklet to the owner and explain its provisions. The owner should retain this booklet for future reference.

**NOTE:** A load calculation must be performed to properly determine the required heating and cooling for the structure. Also, the duct must be properly designed and installed for proper airflow. Existing ductwork must be inspected for proper size and sealed system. Proper airflow is necessary for both user comfort and equipment performance.

**IMPORTANT:** Proper application, installation and maintenance of this equipment is a must if consumers are to receive the full benefit for which they have paid.

### A. R-410A REFRIGERANT

All units are factory charged with R-410A refrigerant.

#### 1. Specification of R-410A:

**Application:** **R-410A is not a drop-in replacement for R-22;** equipment designs must accommodate its higher pressures. It cannot be retrofitted into R-22 units.

**Pressure:** **The pressure of R-410A is approximately 60% (1.6 times) greater than R-22.** Recovery and recycle equipment, pumps, hoses and the like need to have design pressure ratings appropriate for R-410A. *Manifold sets need to range up to 800 psig high-side and 250 psig low-side with a 550 psig low-side retard. Hoses need to have a service pressure rating of 800 psig. Recovery cylinders need to have a 400 psig service pressure rating. DOT 4BA400 or DOT BW400.*

**Combustibility:** At pressures above 1 atmosphere, mixture of R-410A and air can become combustible. **R-410A and air should never be mixed in tanks or supply lines, or be allowed to accumulate in storage tanks. Leak checking should never be done with a mixture of R-410A and air.** Leak checking can be performed safely with nitrogen or a mixture of R-410A and nitrogen.

#### 2. Quick Reference Guide For R-410A

- R-410A refrigerant operates at approximately 60% higher pressure (1.6 times) than R-22. Ensure that servicing equipment is designed to operate with R-410A.
- R-410A refrigerant cylinders are pink.
- R-410A, as with other HFC's is only compatible with POE oils.
- Vacuum pumps will not remove moisture from POE oil.
- R-410A systems are to be charged with liquid refrigerants. Prior to March 1999, R-410A refrigerant cylinders had a dip tube. These cylinders should be kept upright for equipment charging. Post March 1999 cylinders do not have a dip tube and should be inverted to ensure liquid charging of the equipment.
- Do not install a suction line filter drier in the liquid line.
- A liquid line filter drier is standard on every unit.
- Desiccant (drying agent) must be compatible for POE oils and R-410A

#### 3. Evaporator Coil / TXV

The thermostatic expansion valve is specifically designed to operate with R-410A. **DO NOT use an R-22 TXV. The existing evaporator must be replaced with the factory specified TXV evaporator specifically designed for R-410A.**

#### 4. Tools Required For Installing & Servicing R-410A Models

Manifold Sets:

- Up to 800 PSIG High side
- Up to 250 PSIG Low Side
- 550 PSIG Low Side Retard

Manifold Hoses:

- Service Pressure Rating of 800 PSIG

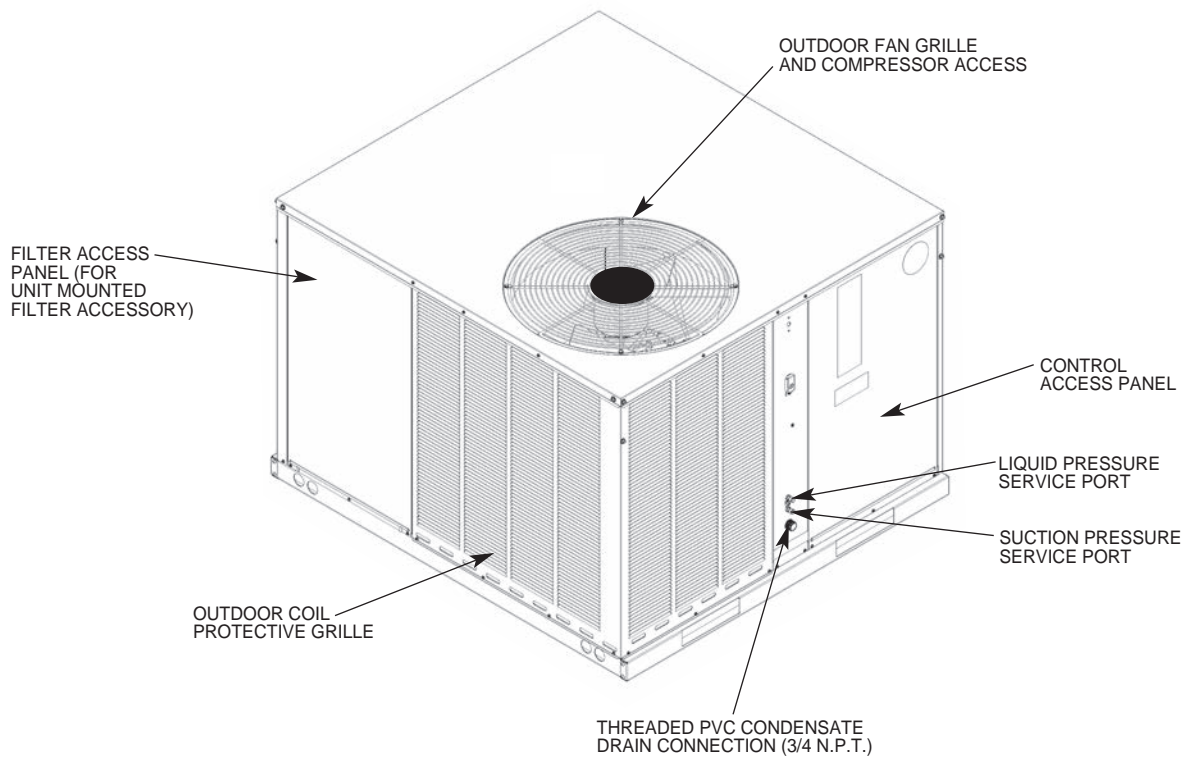
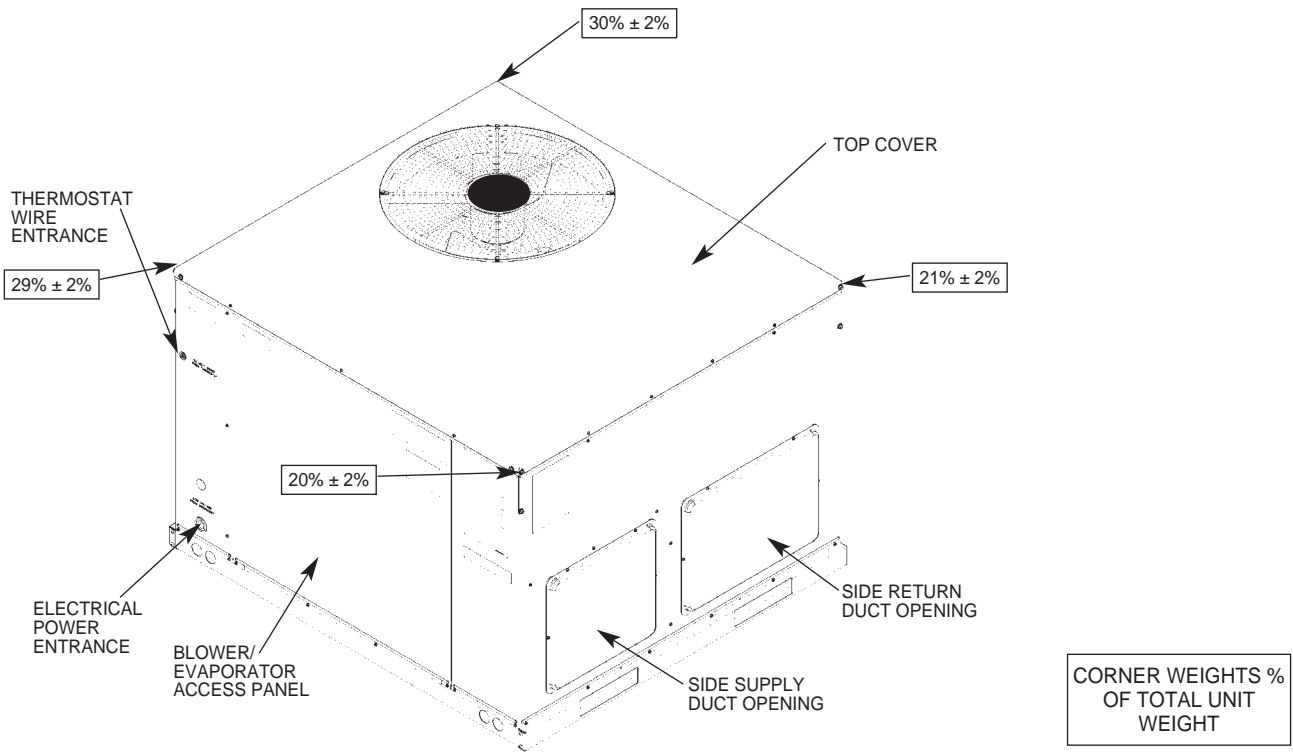
Recovery Cylinders:

- 400 PSIG Pressure Rating
- Dept. of Transportation 4BA400 or BW400

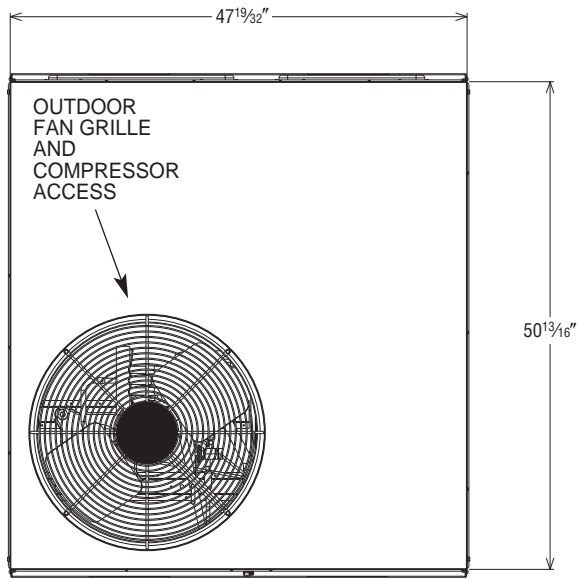
## CAUTION

*R-410A systems operate at higher pressures than R-22 systems. Do not use R-22 service equipment or components on R-410A equipment.*

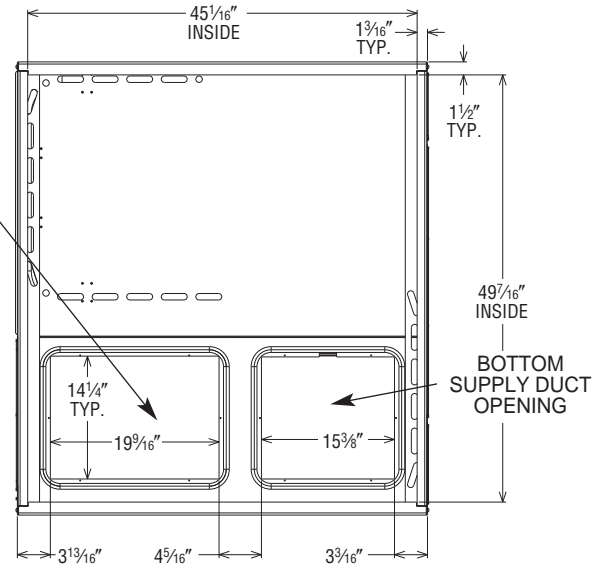
FIGURE 1



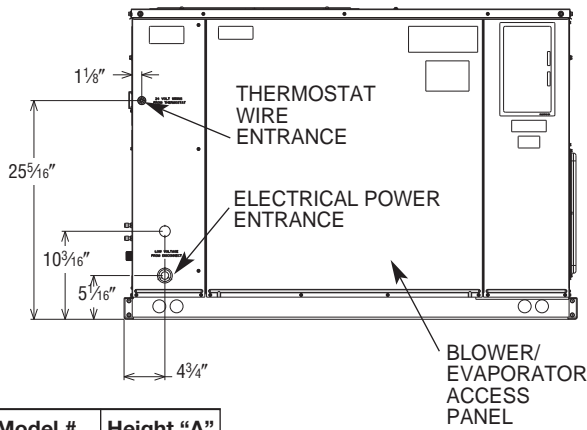
**FIGURE 1**



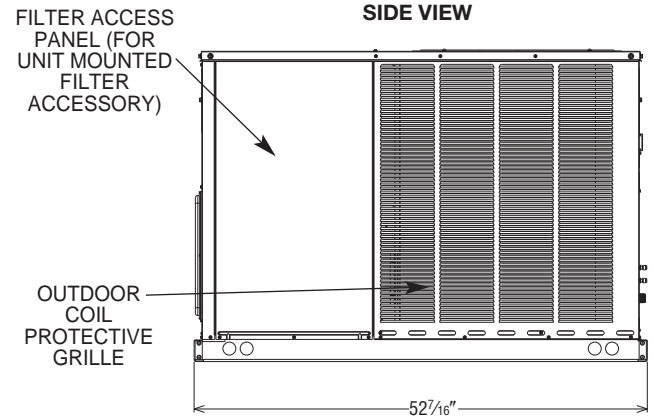
BOTTOM RETURN DUCT OPENING



**SIDE VIEW**



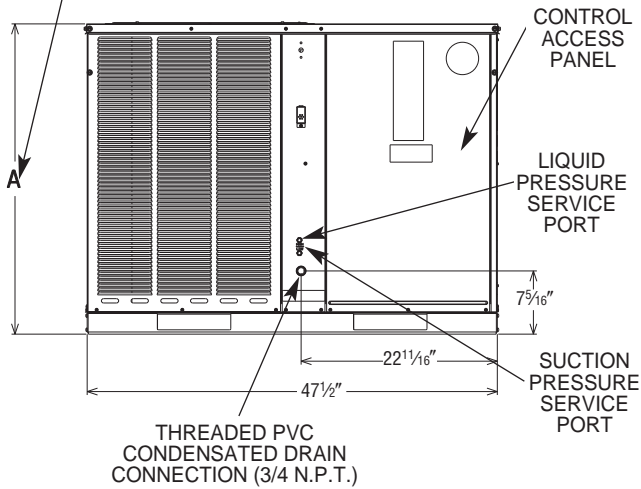
**SIDE VIEW**



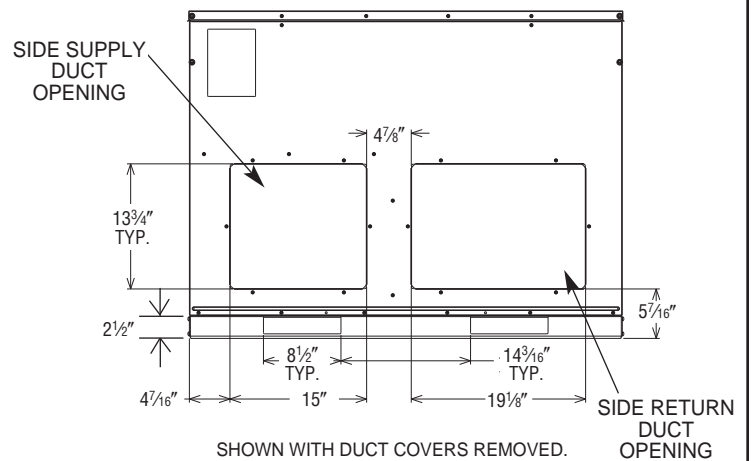
Model #	Height "A"
B024, B025	35 <sup>5</sup> / <sub>16</sub> "
B030, B036 B042, B048	41"

**IMPORTANT:**  
INSTALLATION MUST NOT INTERFERE WITH DRAINAGE OPENINGS IN BOTTOM OF UNIT UNDER OUTDOOR COIL.

**FRONT VIEW**



**REAR VIEW**



## WARNING

THE MANUFACTURER'S WARRANTY DOES NOT COVER ANY DAMAGE OR DEFECT TO THE HEAT PUMP CAUSED BY THE ATTACHMENT OR USE OF ANY COMPONENTS, ACCESSORIES OR DEVICES (OTHER THAN THOSE AUTHORIZED BY THE MANUFACTURER) INTO, ONTO OR IN CONJUNCTION WITH THE HEAT PUMP. YOU SHOULD BE AWARE THAT THE USE OF UNAUTHORIZED COMPONENTS, ACCESSORIES OR DEVICES MAY ADVERSELY AFFECT THE OPERATION OF THE HEAT PUMP AND MAY ALSO ENDANGER LIFE AND PROPERTY. THE MANUFACTURER DISCLAIMS ANY RESPONSIBILITY FOR SUCH LOSS OR INJURY RESULTING FROM THE USE OF SUCH UNAUTHORIZED COMPONENTS, ACCESSORIES OR DEVICES.

## III. CHECKING PRODUCT RECEIVED

Upon receiving the unit, inspect it for any damage from shipment. Claims for damage, either shipping or concealed, should be filed immediately with the shipping company. Check the unit model number, heating size, electrical characteristics, and accessories to determine if they are correct.

## IV. EQUIPMENT PROTECTION FROM THE ENVIRONMENT

The metal parts of this unit may be subject to rust or deterioration in adverse environmental conditions. This oxidation could shorten the equipment's useful life. Salt spray, fog or mist in seacoast areas, sulphur or chlorine from lawn watering systems, and various chemical contaminants from industries such as paper mills and petroleum refineries are especially corrosive.

**If the unit is to be installed in an area where contaminants are likely to be a problem, special attention should be given to the equipment location and exposure.**

1. Avoid having lawn sprinkler heads spray direction on the unit cabinet.
2. In coastal areas, locate the unit on the side of the building away from the waterfront.
3. Shielding provided by a fence or shrubs may give some protection.
4. Elevating the unit off its slab or base enough to allow air circulation will help avoid holding water against the basepan.

**Regular maintenance will reduce the buildup of contaminants and help to protect the unit's finish.**

## WARNING

**DISCONNECT ALL POWER TO THE UNIT BEFORE STARTING MAINTENANCE. FAILURE TO DO SO CAN RESULT IN SEVERE ELECTRICAL SHOCK OR DEATH.**

1. Frequent washing of the cabinet, fan blade and coil with fresh water will remove most of the salt or other contaminants that build up on the unit.
2. Regular cleaning and waxing of the cabinet with an automobile polish will provide some protection.
3. A liquid cleaner may be used several times a year to remove matter that will not wash off with water.

Several different types of protective coatings are offered in some areas. These coatings may provide some benefit, but the effectiveness of such coating materials cannot be verified by the equipment manufacturer.

**The best protection is frequent cleaning, maintenance and minimal exposure to contaminants.**

## V. INSTALLATION

### A. GENERAL

#### 1. PRE-INSTALLATION CHECK-POINTS

Before attempting any installation, the following points should be carefully considered:

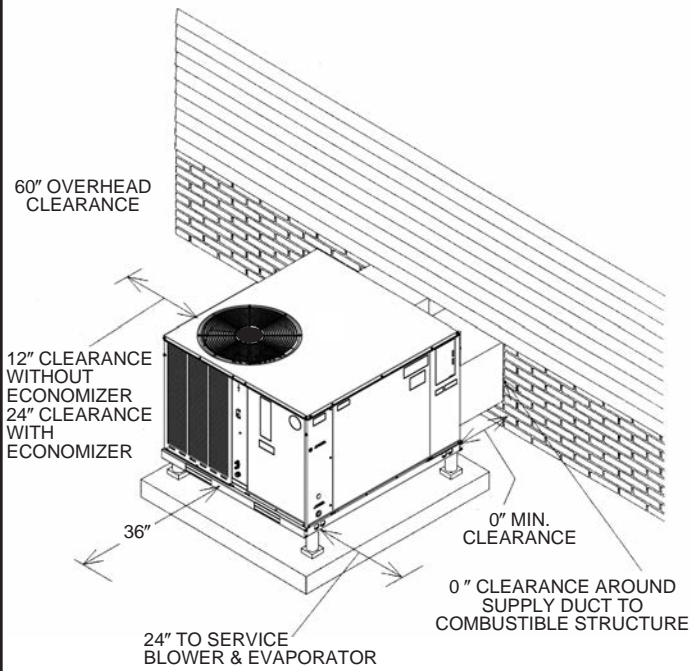
- a. Structural strength of supporting members.  
(rooftop installation)
- b. Clearances and provision for servicing.
- c. Power supply and wiring.
- d. Air duct connections.
- e. Drain facilities and connections.
- f. Location for minimum noise.

#### 2. LOCATION

These units are designed for outdoor installations. They can be mounted on a slab or rooftop. They are not to be installed within any part of a structure such as an attic, crawl space, closet, or any other place where condenser air flow is restricted or other than outdoor ambient conditions prevail. Since the application

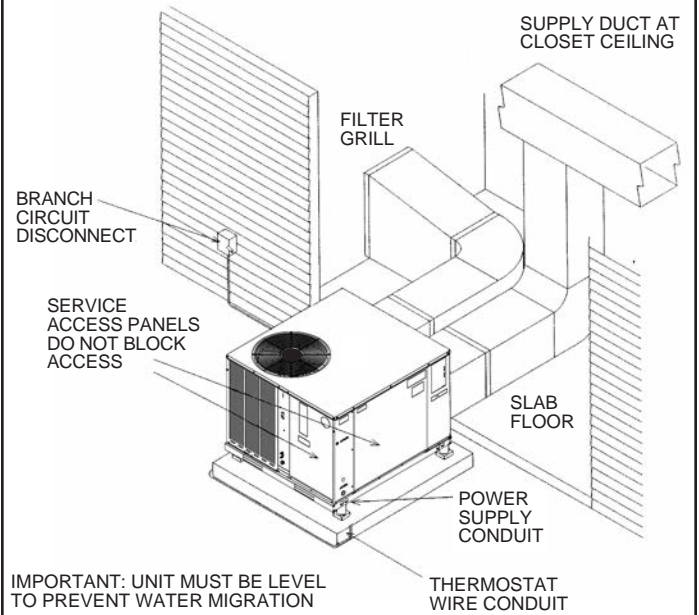


**FIGURE 2**  
**PACKAGE HEAT PUMP**  
 OUTSIDE SLAB INSTALLATION, BASEMENT OR  
 CRAWL SPACE DISTRIBUTION SYSTEM



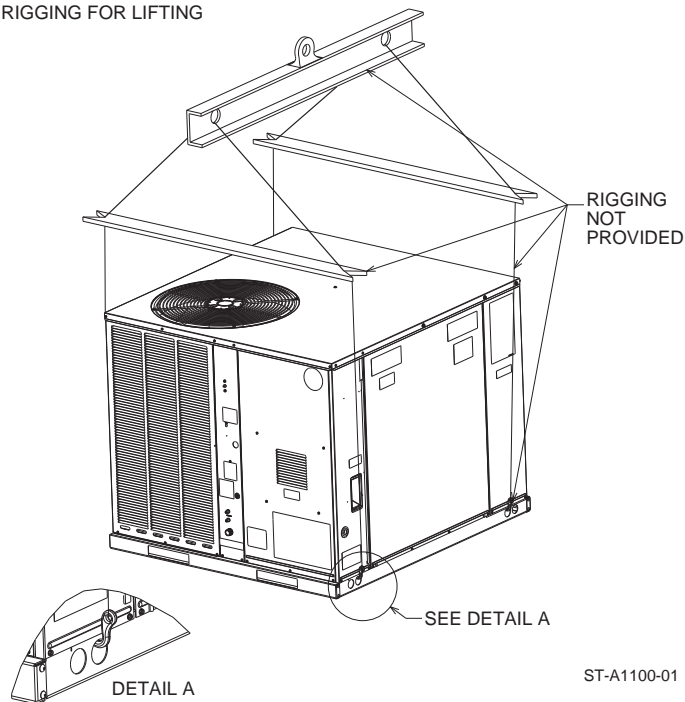
I268

**FIGURE 3**  
**PACKAGE HEAT PUMP**  
 OUTSIDE SLAB INSTALLATION, CLOSET DISTRIBUTION



I267

**FIGURE 4**  
**PACKAGE HEAT PUMP**  
 RIGGING FOR LIFTING



ST-A1100-01

of the units is of the outdoor type, it is important to consult your local code authorities at the time the first installation is made.

#### **B. OUTSIDE SLAB INSTALLATION (Typical outdoor slab installations are shown in Figures 2 and 3.)**

1. Select a location where external water drainage cannot collect around the unit.
2. Provide a level concrete slab extending a minimum 3" beyond all four sides of the unit. The slab should be sufficient above grade to prevent ground water from entering the unit. **IMPORTANT:** *To prevent transmission of noise or vibration, slab should not be connected to building structure.*
3. The location of the unit should be such as to provide proper access for inspection and servicing.
4. Locate unit where operating sounds will not disturb owner or neighbors.
5. Locate unit so roof runoff water does not pour directly on the unit. Provide gutter or other shielding at roof level. Do not locate unit in an area where excessive snow drifting may occur or accumulate.
6. It is essential that the unit be elevated above the base pad to allow for condensate drainage and possible refreezing of condensation. Provide a base pad which is slightly pitched away from the structure. Route condensate off base pad to an area which will not become slippery and result in personal injury. **IMPORTANT:** *Do not interfere with openings in bottom of unit.*
7. Where snowfall is anticipated, the height of the unit above the ground level must be considered. Mount unit high enough to be above average area snowfall and to allow for proper condensate drainage. **IMPORTANT:** *Do not interfere with openings in bottom of unit.*

#### **C. CLEARANCES**

The following minimum clearances must be observed for proper unit performance and serviceability.

1. Provide 36" minimum clearance at the front and right side of the unit for service access. Provide 12" minimum clearance on the left side of the unit for air inlet.
2. Provide 60" minimum clearance between top of unit and maximum 3 foot overhang.
3. Unit is design certified for application on combustible flooring with 0" minimum clearance.
4. See Figure 2 for illustration of minimum installation-service clearances.

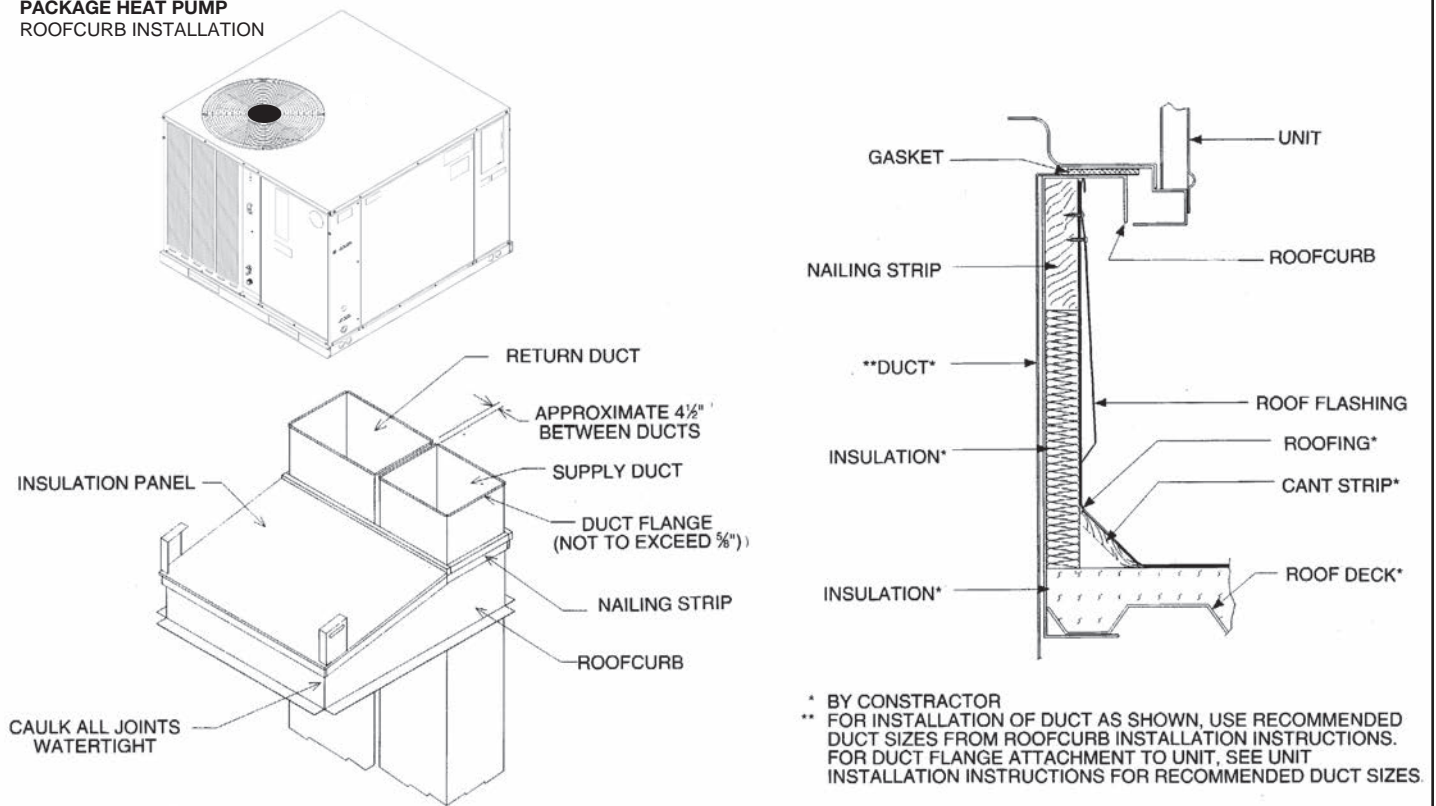
#### **D. ROOFTOP INSTALLATION**

1. Before locating the unit on the roof, make sure that the strength of the roof and beams is adequate at that point to support the weight involved. (See specification sheet for weight of unit.) This is very important and user's responsibility.
2. For rigging and roofcurb details, see Figures 4 and 5. Use accessory lift brackets and field-furnished spreaders.
3. For roofcurb assembly, see Roofcurb Installation Instructions.
4. If the roofcurb is not used, provisions for disposing of condensate water runoff during defrosting must be provided.
5. The unit should be placed on a solid and level roofcurb or platform of adequate strength. **IMPORTANT:** *Do not interfere with opening in bottom of unit. (See Figures 6 and 7.)*
6. The location of the unit on the roof should be such as to provide proper access for inspection and servicing.

**IMPORTANT:** *If unit will not be put into service immediately, cover supply and return openings to prevent excessive condensation.*

**FIGURE 5**

**PACKAGE HEAT PUMP  
ROOFCURB INSTALLATION**



1270

1271

## VI. DUCTWORK

Ductwork should be fabricated by the installing contractor in accordance with local codes, state codes and NFPA90A. Industry manuals may be used as a guide when sizing and designing the duct system - contact Air Conditioning Contractors of America, 1513 16th St. N.W., Washington, D.C. 20036.

### **⚠ WARNING**

**DO NOT, UNDER ANY CIRCUMSTANCES, CONNECT RETURN DUCTWORK TO ANY OTHER HEAT PRODUCING DEVICE SUCH AS A FIREPLACE INSERT, STOVE, ETC. UNAUTHORIZED USE OF SUCH DEVICES MAY RESULT IN FIRE, CARBON MONOXIDE POISONING, EXPLOSION, PROPERTY DAMAGE,**

Place the unit as close to the space to be air conditioned as possible allowing clearance dimensions as indicated. Run ducts as directly as possible to supply and return outlets. Use of non-flammable waterproof flexible connectors on both supply and return connections at the unit to reduce noise transmission is recommended.

It is preferable to install the unit on the roof of the structure if the registers or diffusers are located on the wall or in the ceiling. Consider a slab installation when the registers are low on a wall or in the floor.

On ductwork exposed to outside air conditions of temperature and humidity, use a minimum of 2" of insulation and a vapor barrier. Distribution system in attic, furred space or crawl space should be insulated with at least 2" of insulation with vapor barrier. One-half to 1" thickness of insulation is usually sufficient for ductwork inside the air conditioned space.

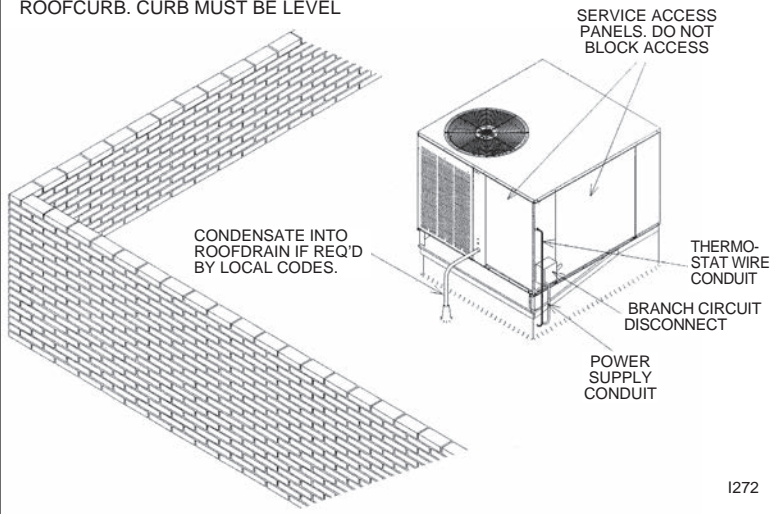
Provide balancing dampers for each branch duct in the supply system. Properly support the ductwork from the structure.

When installing ductwork use noncombustible flexible connectors between ductwork and unit to reduce noise and vibration transmission into the ductwork.

**FIGURE 6**

**PACKAGE HEAT PUMP**

FLAT ROOFTOP INSTALLATION, ATTIC OR DROP CEILING DISTRIBUTION SYSTEM. MOUNTED ON ROOFCURB. CURB MUST BE LEVEL



## VII. FILTERS

Filters are not provided with this unit. They may be supplied and installed in the return air duct by the installer. A field installed filter grille is recommended for easy and convenient access to the filters for periodic inspection and cleaning. Filters must have adequate face area for the rated air quantity of the unit. See Airflow Performance Table - or Electrical and Physical Data Table - for recommended filter size.

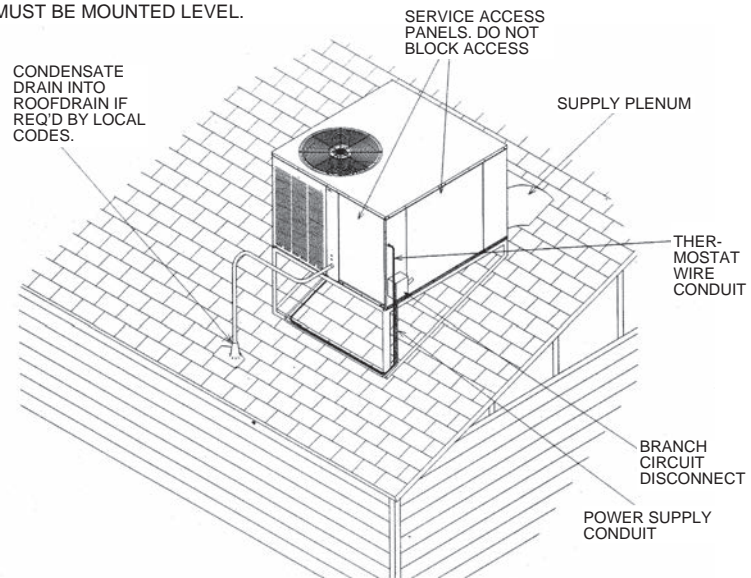
However, if an internal filter is required, an optional internal filter kit is available which will work for downflow or horizontal applications. For installation, see Filter Kit Installation Instruction.

**NOTE:** Do not operate the system without filters.

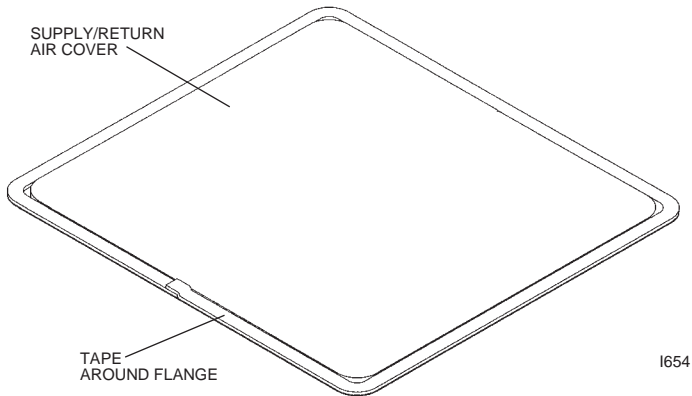
**FIGURE 7**

**PACKAGE HEAT PUMP**

PITCHED ROOFTOP INSTALLATION, ATTIC OR DROP CEILING DISTRIBUTING SYSTEM. MUST BE MOUNTED LEVEL.



**FIGURE 8**  
**COVER GASKET DETAIL**  
 FOR UNITS SHIPPED FOR SIDE DISCHARGE  
 APPLICATION BEING CONVERTED TO DOWNFLOW



## VIII. CONVERSION PROCEDURE

1. DOWNFLOW TO HORIZONTAL
  - a. Remove screws and covers from outside of supply and return sections.
  - b. Install gasket (supplied with parts bag) around perimeter of covers as illustrated in "Cover Gasket Detail," Figure 8.
  - c. Install covers in bottom of unit with insulated side up.
 

**NOTE:** Slip back flange of cover under tab on bottom supply duct opening.
  - d. Secure covers to base of unit with screw engaging prepunched holes in unit base.
2. HORIZONTAL TO DOWNFLOW
  - a. Remove screws and covers from the downflow supply and return sections. Both covers are accessible from the inside of the unit.
 

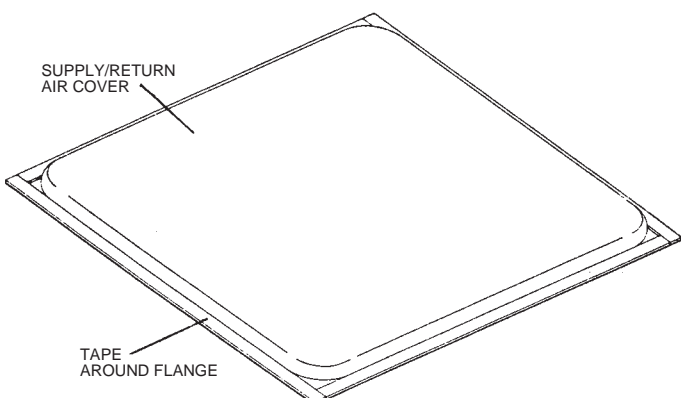
**NOTE:** Supply cover must be rotated 90° before it can be removed.
  - b. Install gasket (supplied with parts bag) around perimeter of cover on the insulated side. See Figure 9.
  - c. Install covers on the outside of the unit over the horizontal supply and return opening using existing screws.

## IX. CONDENSATE DRAIN

The indoor coil condensate drain ends with a threaded (3/4" NPT) PVC stub. A trap is built in for proper condensate drainage and to prevent debris from being drawn into the unit. Do not connect drain to closed sewer line. It is recommended that a PVC cement not be used so that the drain line can be easily cleaned in the future.

**NOTE:** Do not install an external trap.

**FIGURE 9**  
**COVER GASKET DETAIL**  
 FOR UNITS SHIPPED FOR DOWNFLOW APPLICATION  
 BEING CONVERTED TO SIDE DISCHARGE



## X. CONDENSATE DRAIN, OUTDOOR COIL

The outdoor coil during heating operation will sweat or run water off. The outdoor coil will also run water off during the defrost cycle. See Section V, Installation, for mounting precautions.

## XI. ELECTRICAL WIRING

Field wiring must comply with the National Electrical Code\* state and local ordinances that may apply.

\*C.E.C. in Canada

### A. POWER WIRING

1. It is important that proper electrical power is available at the unit. Voltage should not vary more than 10% from that stamped on the unit rating plate. On three phase units, phases must be balanced within 3%.
2. Install a branch circuit disconnect within sight of the unit and of adequate size to handle the starting current.
3. For branch circuit wiring (main power supply to unit disconnect), the minimum wire size can be determined from the circuit ampacity found on the unit nameplate or from Table F and the National Electrical Code or Canadian Electrical Code.
4. This unit incorporates single point electrical connection for unit and electric heat accessory.
5. Power wiring must be run in grounded rain-tight conduit. Connect the power field wiring as follows:
  - a. NO ELECTRIC HEAT - Connect the field wires directly to the contactor in the unit control box. Connect ground wire to ground lug.
  - b. WITH ELECTRIC HEAT - Connect the field wires to the terminal block on the electric heater kit. Connect the ground wire to the ground lug on the heater kit.

**NOTE:** For installation of the heater kit, follow the instructions provided with the heater kit.
6. The pigtail wires in the electric heat box are factory wired to the contactor in the control box and are protected by internal fuses in the hinged fuse box mounted under the control box. See label on fuse box cover for fuse sizing.
7. DO NOT connect aluminum field wires to electric heat kit power input terminals.

### B. CONTROL WIRING (Class II)

1. Do not run low voltage wiring in conduit with power wiring.
2. Control wiring is routed through the 7/8" hole approximately 11" from the unit top in the corner post adjacent to the control box. Use a minimum #18 AWG thermostat wire. For wire lengths exceeding 50', use #16 AWG thermostat wire. The low voltage wires are connected to the unit pigtails which are supplied with the unit in the low voltage connection box located below the unit control box. See Figure 10.
3. It is necessary that only heat pump thermostats be used. Please contact your distributor for part number information.
4. Figure 11 shows representative low voltage connection diagrams. Read your thermostat installation instructions for any special requirements for your specific thermostat. These connection diagrams are wired to minimize the amount of auxiliary electric heaters to be energized during defrost.

**NOTE:** Units installed in Canada require that an outdoor thermostat (30,000 min. cycles of endurance) be installed and be wired with C.E.C. Class I wiring.

### C. INTERNAL WIRING

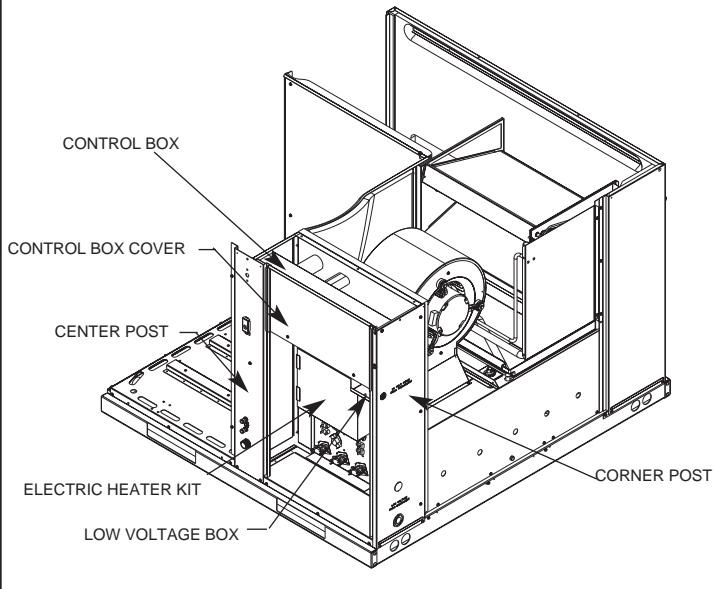
1. A diagram of the internal wiring of this unit is located on the electrical control box cover. If any of the original wire as supplied with the appliance must be replaced, the wire gauge and insulation must be the same as original wiring.

### D. GROUNDING

#### WARNING

**THE UNIT MUST BE PERMANENTLY GROUNDED. A GROUNDING LUG IS PROVIDED IN THE ELECTRIC HEAT KIT FOR A GROUND WIRE. (SEE FIGURE 10.) FAILURE TO GROUND THIS UNIT CAN RESULT IN FIRE OR ELECTRICAL SHOCK CAUSING PROPERTY DAMAGE, SEVERE PERSONAL INJURY OR DEATH.**

**FIGURE 10**

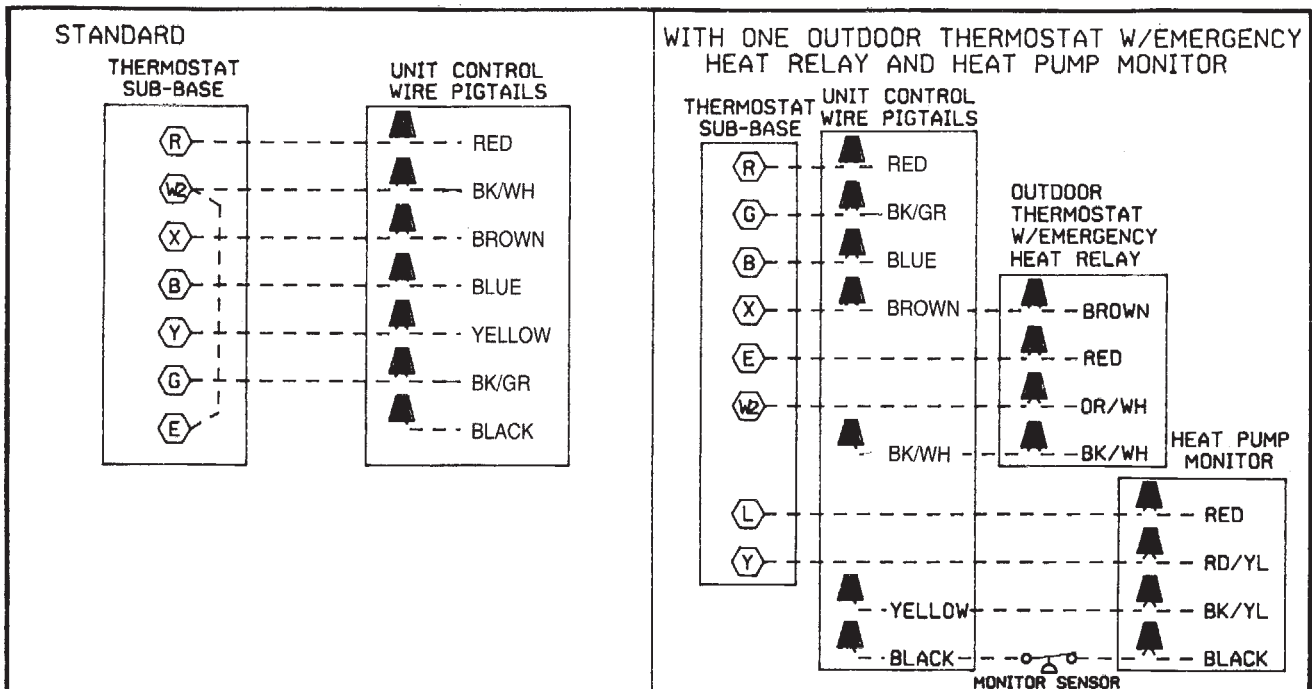


GROUNDING MAY ALSO BE ACCOMPLISHED BY GROUNDING THE POWER LINE CONDUIT TO THE UNIT. MAKE SURE THE CONDUIT NUT LOCKING TEETH HAVE PIERCED THE INSULATING PAINT FILM OF THE SIDE PANEL.

**E. THERMOSTAT**

Mount the thermostat on an inside wall about five feet above the floor in a location where it will not be affected by unconditioned air, sun, or drafts from open doors or other sources. READ installation instructions in heat pump thermostat package CAREFULLY because each has some different wiring requirements.

**FIGURE 11**  
VOLTAGE CONNECTIONS DIAGRAMS



IF EMERGENCY HEAT RELAY AND OUTDOOR THERMOSTATS ARE NOT USED, A JUMPER BETWEEN 'W2' AND 'E' CAN BE INSTALLED TO TRANSFER CONTROL OF HEATING TO THE FIRST STAGE WHEN THE SYSTEM SWITCH IS IN THE EMERGENCY HEAT POSITION.

## XII. INDOOR AIR FLOW DATA

All 208/230 volt units are equipped with multi-speed indoor blower motors. Each unit is shipped factory wired for the proper speed at a normal external static. See the blower performance data in this manual.

---

## XIII. CRANKCASE HEAT (OPTIONAL)

At initial startup or after extended shutdown periods, make sure crankcase heat is energized for at least 12 hours before compressor is started (disconnect switch closed and wall thermostat "OFF" position).

Crankcase heat is not required on scroll type compressors, but may be necessary for difficult starting situations.

---

## XIV. PRE-START CHECK

1. Is unit properly located and slightly slanted toward indoor condensate drain?
  2. Is ductwork insulated, weatherproofed, with proper spacing to combustible materials?
  3. Is air free to travel to and from outdoor coil? (See Figure 2.)
  4. Is the wiring correct, tight, and according to unit wiring diagram?
  5. Is unit grounded?
  6. Are field supplied air filters in place and clean?
  7. Do the outdoor fan and indoor blower turn freely without rubbing, and are they tight on the motor shafts?
  8. Has crankcase heat (if required) been on for at least 12 hours?
  9. Is unit elevated to allow for outdoor coil condensate drainage during heating operation and defrost?
- 

## XV. STARTUP

1. Turn thermostat to "OFF," turn "on" power supply at disconnect switch.
2. Turn temperature setting as high as it will go.
3. Turn fan switch to "ON."
4. Indoor blower should run. Be sure it is running in the right direction.
5. Adjust discharge air grilles and balance system.
6. Turn fan switch to "AUTO." Turn system switch to "COOL" and turn temperature setting below room temperature. Unit should run in cooling mode.
7. Is outdoor fan operating correctly in the right direction?
8. Is compressor running correctly.
9. Turn thermostat system switch to "HEAT." Unit should stop. Wait 5 minutes, then raise temperature setting to above room temperature. Unit should run in heating mode and after about 30 to 50 seconds auxiliary heaters, if installed, should come on.
10. Check the refrigerant charge using the instructions located on control box cover. Replace service port caps. Service port cores are for system access only and will leak if not tightly capped.
11. Turn thermostat system switch to proper mode "HEAT" or "COOL" and set thermostat to proper temperature setting. Record the following after the unit has run some time.
  - A. Operating Mode \_\_\_\_\_
  - B. Discharge Pressure (High) \_\_\_\_\_ PSIG
  - C. Vapor Pressure at Compressor (Low) \_\_\_\_\_ PSIG
  - D. Vapor Line Temperature at Compressor \_\_\_\_\_ °F.
  - E. Indoor Dry Bulb \_\_\_\_\_ °F.
  - F. Indoor Wet Bulb \_\_\_\_\_ °F.
  - G. Outdoor Dry Bulb \_\_\_\_\_ °F.
  - H. Outdoor Wet Bulb \_\_\_\_\_ °F.
  - I. Voltage at Contactor \_\_\_\_\_ Volts
  - J. Current at Contactor \_\_\_\_\_ Amps
  - K. Model Number \_\_\_\_\_
  - L. Serial Number \_\_\_\_\_
  - M. Location \_\_\_\_\_
  - N. Owner \_\_\_\_\_
  - O. Date \_\_\_\_\_



12. Check ducts for condensation and air leaks.
  13. Check unit for tubing and sheet metal rattles.
  14. Instruct the owner on operation and maintenance.
  15. Leave "INSTALLATION" and "USE AND CARE" instructions with owner
- 

## XVI. OPERATION

Most single phase units are operated PSC (no start relay or start capacitor). It is important that such systems be off for a minimum of 5 minutes before restarting to allow equalization of pressures. Do not move the thermostat to cycle unit without waiting five minutes. To do so may cause the compressor to stop on an automatic open overload device or blow a fuse. Poor electrical service can cause nuisance tripping in overloads or blow fuses.

**IMPORTANT:** *The compressor has an internal overload protector. Under some conditions, it can take up to 2 hours for this overload to reset. Make sure overload has had time to reset before condemning the compressor.*

Some models may be factory equipped with a start relay and start capacitor.

Most single phase 208/240 volt units are equipped with a time delay control (TDC1). The control allows the blower to operate for up to 90 seconds after the thermostat is satisfied.

---

## XVII. AUXILIARY HEAT

The amount of auxiliary heat required depends on the heat loss of the structure to be heated and the capacity of the heat pump. It is good practice to install strip heat to maintain at least 60°F indoor temperatures in case of compressor failure. The auxiliary heat is energized by the second stage of the thermostat. The amount of electric heat that is allowed to come on, as determined by the output of the heat pump, may be controlled by an outdoor thermostat.

### **WARNING**

**ONLY ELECTRIC HEATER KITS SUPPLIED BY THIS MANUFACTURER AS DESCRIBED IN THIS PUBLICATION HAVE BEEN DESIGNED, TESTED, AND EVALUATED BY A NATIONALLY RECOGNIZED SAFETY TESTING AGENCY FOR USE WITH THIS UNIT. USE OF ANY OTHER MANUFACTURED ELECTRIC HEATERS INSTALLED WITHIN THIS UNIT MAY CAUSE HAZARDOUS CONDITIONS RESULTING IN PROPERTY DAMAGE, FIRE, BODILY INJURY OR DEATH.**

#### **A. CONTROL SYSTEM OPERATION**

1. In the cooling mode, the thermostat will, on a call for cooling, energize the compressor contactor and the indoor blower relay. The indoor blower can be operated continuously by setting the thermostat fan switch at the "ON" position. The reversing valve coil is de-energized when the changeover relay is energized.
2. In the heating mode, the first heat stage of the thermostat will energize the compressor contactor and the indoor blower relay. The second heat stage will turn on one or more supplementary resistance heaters. The reversing valve is energized except in defrost. If required or considered desirable, the resistance heat may also be controlled by outdoor thermostats.

## **XVIII. DEMAND DEFROST CONTROL AND HIGH/LOW PRESSURE CONTROLS**

The demand defrost control is a printed circuit board assembly consisting of solid state control devices with electro-mechanical outputs. The demand defrost control monitors the outdoor ambient temperature, outdoor coil temperature, and the compressor run-time to determine when a defrost cycle is required.

**Enhanced Feature Demand Defrost Control:** Has high and low pressure control inputs with unique pressure switch logic built into the microprocessor to provide compressor and system protection without nuisance lock-outs. Cycles the compressor off for 30 seconds at the beginning and end of the defrost cycle to eliminate the increased compressor noise caused by rapidly changing system pressures when the reversing valve switches. See the end of this section for diagnostic flash codes for the two diagnostic LED's provided on the control.

### **DEFROST INITIATION**

A defrost will be initiated when the three conditions below are satisfied:

- 1) The outdoor coil temperature is below 35°F.
- 2) The compressor has operated for at least 34 minutes with the outdoor coil temperature below 35°F.
- 3) The measured difference between the ambient temperature and the outdoor coil temperature is greater than the calculated delta T.

Additionally, a defrost will be initiated if six hours of accumulated compressor run-time has elapsed without a defrost with the outdoor coil temperature below 35°F.

### **DEFROST TERMINATION**

Once a defrost is initiated, the defrost will continue until fourteen minutes has elapsed or the coil temperature has reached the terminate temperature. The terminate temperature is factory set at 70°F, although the temperature can be changed to 50°F, 60°F, 70°F or 80°F by relocating a jumper on the board.

### **TEMPERATURE SENSORS**

The coil sensor is clipped to the outdoor coil. The air sensor is located in the outdoor coil compartment.

If the ambient sensor fails the defrost control will initiate a defrost every 34 minutes with the coil temperature below 35°F.

If the coil sensor fails the defrost control will not initiate a defrost.

### **TEST MODE**

The test mode is initiated by shorting the TEST pins. In this mode of operation, the enable temperature is ignored and all timers are sped up by a factor of 240. To initiate a manual defrost, short the TEST pins. Remove the short when the system switches to defrost mode. The defrost will terminate on time (14 minutes) or when the termination temperature has been achieved. Short TEST pins again to terminate the defrost immediately.

### **TROUBLE SHOOTING DEMAND DEFROST**

Set the indoor thermostat select switch to heat and initiate a call for heat.

Jumper the "test pins" to put the unit into defrost. If the unit goes into defrost and comes back out of defrost, the indication is that the control is working properly.

If the unit did not go into defrost using the test pins, check to ensure that 24V is being supplied to the control board. If 24V is present then replace the control.

### **HIGH/LOW PRESSURE CONTROL MONITORING - ENHANCED DEFROST CONTROL**

Status of high and low pressure controls is monitored by the enhanced feature demand defrost control and the following actions are taken.

**High Pressure Control** – Provides active protection in both cooling and heating modes at all outdoor ambient temperatures. The high pressure control is an automatic reset type and opens at approximately 610 psig and closes at approximately 420 psig. The compressor and fan motor will stop when the high pressure control opens and will start again if the high side pressure drops to approximately 420 psig

when the automatic reset high pressure control resets. If the high pressure control opens 3 times within a particular call for heating or cooling operation, the defrost control will lock out compressor and outdoor fan operation.

**Low Pressure Control** – Provides active protection in both heating and cooling modes at all outdoor ambient temperatures. The low pressure control is an automatic reset type and opens at approximately 15 psig and closes at approximately 40 psig. Operation is slightly different between cooling and heating modes.

**Cooling Mode:** The compressor and fan motor will stop when the low pressure control opens and will start again when the low side pressure rises to approximately 40 psig when the low pressure control automatically resets. If the low pressure switch opens 3 times within a particular call for cooling operation, the defrost control will lock out compressor and outdoor fan operation.

**Heating Mode:** The compressor and fan motor will stop when the low pressure control opens and will start again when the low side pressure rises to approximately 40 psig when the low pressure control automatically resets. If the low pressure switch trips 3 times within 120 minutes of operation during a particular call for heating operation, the defrost control will lock out compressor and outdoor fan operation. If the lock-out due to low pressure occurs at an outdoor ambient temperature below 5°F, the defrost control will automatically exit the lock-out mode when the outdoor ambient temperature rises to 5°F. This feature is necessary since the low pressure control could possibly have opened due to the outdoor ambient being very low rather than an actual system fault.

**Exiting Lock-Out Mode:** To exit the lock-out mode, remove 24 volts to the defrost control by removing power to indoor air-handler/furnace or by shorting the two defrost control test pins together.

## ENHANCED FEATURE DEFROST CONTROL DIAGNOSTIC CODES

LED 1	LED 2	Control Board Status
OFF	OFF	No Power
ON	ON	Coil Sensor Failure
OFF	ON	Ambient Sensor Failure
FLASH	FLASH	Normal
OFF	FLASH	Low Pressure Lockout (short test pins to reset)
FLASH	OFF	High Pressure Lockout (short test pins to reset)
ON	FLASH	Low Pressure Control Open
FLASH	ON	High Pressure Control Open
Alternate Flashing		5 Minute Time Delay

# XIX. GENERAL DATA - RQNL- MODELS

## NOMINAL SIZES 2-4 TONS [7.1-14.6 kW]

Model RQNL - Series	B024JK	B030JK	B036CK	B036JK
<b>Cooling performance<sup>1</sup></b>				<b>Continued -&gt;</b>
Gross Cooling Capacity Btu [kW]	24,400 [7.15]	29,000 [8.5]	36,200 [10.61]	36,200 [10.61]
EER, SEER <sup>2</sup>	11/13	11/13	11/13	11/13
Nominal CFM/ARI Rated CFM [L/s]	800/800 [378/378]	1000/1000 [472/472]	1200/1250 [566/590]	1200/1250 [566/590]
ARI Net Cooling Capacity Btu [kW]	23,600 [6.91]	27,800 [8.15]	35,000 [10.26]	35,000 [10.26]
Net Sensible Capacity Btu [kW]	17,600 [5.16]	20,800 [6.09]	26,000 [7.62]	26,000 [7.62]
Net Latent Capacity Btu [kW]	6,000 [1.76]	7,000 [2.05]	9,000 [2.64]	9,000 [2.64]
Net System Power kW	2.15	2.53	3.18	3.18
<b>Heating Performance (Heat Pumps)<sup>3</sup></b>				
High Temp. Btuh [kW] Rating	23,600 [6.91]	28,200 [8.26]	34,000 [9.96]	34,000 [9.96]
System Power KW / COP	2.02/3.4	2.45/3.4	2.86/3.5	2.86/3.5
Low Temp. Btuh [kW] Rating	13,000 [3.81]	16,000 [4.69]	19,500 [5.71]	19,500 [5.71]
System Power KW / COP	1.9/2	2.26/2.1	2.61/2.2	2.61/2.2
HSPF (Btu/Watts-hr)	7.7	7.7	7.7	7.7
<b>Compressor</b>				
No./Type	1/Copeland Scroll	1/Copeland Scroll	1/Copeland Scroll	1/Copeland Scroll
<b>Outdoor Sound Rating (dB)<sup>4</sup></b>	76	76	76	76
<b>Outdoor Coil - Fin Type</b>	Louvered	Louvered	Louvered	Louvered
Tube Type	Rifled	Rifled	Rifled	Rifled
Tube Size in. [mm] OD	0.375 [9.5]	0.375 [9.5]	0.375 [9.5]	0.375 [9.5]
Face Area sq. ft. [sq. m]	14.51 [1.35]	16.32 [1.52]	11.2 [1.04]	11.2 [1.04]
Rows / FPI [FPcm]	1 / 22 [9]	1 / 22 [9]	2 / 22 [9]	2 / 22 [9]
Refrigerant Control	TX Valves	TX Valves	TX Valves	TX Valves
<b>Indoor Coil - Fin Type</b>	Louvered	Louvered	Louvered	Louvered
Tube Type	Rifled	Rifled	Rifled	Rifled
Tube Size in. [mm]	0.375 [9.5]	0.375 [9.5]	0.375 [9.5]	0.375 [9.5]
Face Area sq. ft. [sq. m]	5.54 [0.51]	7.39 [0.69]	7.39 [0.69]	7.39 [0.69]
Rows / FPI [FPcm]	2 / 15 [6]	2 / 15 [6]	2 / 15 [6]	2 / 15 [6]
Refrigerant Control	TX Valves	TX Valves	TX Valves	TX Valves
Drain Connection No./Size in. [mm]	1/1 [25.4]	1/1 [25.4]	1/1 [25.4]	1/1 [25.4]
<b>Outdoor Fan - Type</b>	Propeller	Propeller	Propeller	Propeller
No. Used/Diameter in. [mm]	1/22 [558.8]	1/22 [558.8]	1/22 [558.8]	1/22 [558.8]
Drive Type/No. Speeds	Direct/1	Direct/1	Direct/1	Direct/1
CFM [L/s]	2700 [1274]	2700 [1274]	2700 [1274]	2700 [1274]
No. Motors/HP	1 at 1/5 HP	1 at 1/5 HP	1 at 1/5 HP	1 at 1/5 HP
Motor RPM	1075	1075	1075	1075
<b>Indoor Fan - Type</b>	FC Centrifugal	FC Centrifugal	FC Centrifugal	FC Centrifugal
No. Used/Diameter in. [mm]	1/9x7 [228.6x177.8]	1/10x9 [254x228.6]	1/10x9 [254x228.6]	1/10x9 [254x228.6]
Drive Type/No. Speeds	Direct/2	Direct/3	Direct/1	Direct/1
No. Motors	1	1	1	1
Motor HP	1/4	1/2	1/3	1/3
Motor RPM	1075	1075	1075	1075
Motor Frame Size	48	48	48	48
<b>Filter - Type</b>	Field Supplied	Field Supplied	Field Supplied	Field Supplied
Furnished	No	No	No	No
(NO.) Size Recommended in. [mm x mm x mm]	(1)1x20x20 [25x508x508]	(1)1x24x24 [25x610x610]	(1)1x24x24 [25x610x610]	(1)1x24x24 [25x610x610]
<b>Refrigerant Charge Oz. [g]</b>	98 [2778]	108 [3062]	146 [4139]	146 [4139]
<b>Weights</b>				
Net Weight lbs. [kg]	391 [177]	444 [201]	471 [214]	468 [212]
Ship Weight lbs. [kg]	401 [182]	455 [206]	482 [219]	479 [217]

# GENERAL DATA - RQNL- MODELS

## NOMINAL SIZES 2-4 TONS [7.1-14.6 kW]

Model RQNL - Series	B042CK	B042JK	B048CK	B048JK
<b>Cooling performance<sup>1</sup></b>				
Gross Cooling Capacity Btu [kW]	43,500 [12.75]	43,500 [12.75]	49,000 [14.36]	49,000 [14.36]
EER, SEER <sup>2</sup>	11/13	11/13	11/13	11/13
Nominal CFM/ARI Rated CFM [L/s]	1400/1400 [661/661]	1400/1400 [661/661]	1600/1600 [755/755]	1600/1600 [755/755]
ARI Net Cooling Capacity Btu [kW]	42,500 [12.45]	42,500 [12.45]	47,500 [13.92]	47,500 [13.92]
Net Sensible Capacity Btu [kW]	31,500 [9.23]	31,500 [9.23]	36,000 [10.55]	36,000 [10.55]
Net Latent Capacity Btu [kW]	11,000 [3.22]	11,000 [3.22]	11,500 [3.37]	11,500 [3.37]
Net System Power kW	3.86	3.86	4.31	4.31
<b>Heating Performance (Heat Pumps)<sup>3</sup></b>				
High Temp. Btuh [kW] Rating	41,500 [12.16]	41,500 [12.16]	46,000 [13.48]	46,000 [13.48]
System Power KW / COP	3.65/3.4	3.65/3.4	3.89/3.4	3.89/3.4
Low Temp. Btuh [kW] Rating	24,200 [7.09]	24,200 [7.09]	26,600 [7.79]	26,600 [7.79]
System Power KW / COP	3.43/2.08	3.43/2.08	3.57/2.2	3.57/2.2
HSPF (Btu/Watts-hr)	7.7	7.7	7.7	7.7
<b>Compressor</b>				
No./Type	1/Copeland Scroll	1/Copeland Scroll	1/Copeland Scroll	1/Copeland Scroll
<b>Outdoor Sound Rating (dB)<sup>4</sup></b>				
	76	76	78	78
<b>Outdoor Coil - Fin Type</b>				
Tube Type	Louvered	Louvered	Louvered	Louvered
Tube Size in. [mm] OD	0.375 [9.5]	0.375 [9.5]	0.375 [9.5]	0.375 [9.5]
Face Area sq. ft. [sq. m]	16.32 [1.52]	16.32 [1.52]	16.32 [1.52]	16.32 [1.52]
Rows / FPI [FPcm]	2 / 22 [9]	2 / 22 [9]	2 / 22 [9]	2 / 22 [9]
Refrigerant Control	TX Valves	TX Valves	TX Valves	TX Valves
<b>Indoor Coil - Fin Type</b>				
Tube Type	Louvered	Louvered	Louvered	Louvered
Tube Size in. [mm]	0.375 [9.5]	0.375 [9.5]	0.375 [9.5]	0.375 [9.5]
Face Area sq. ft. [sq. m]	7.39 [0.69]	7.39 [0.69]	7.39 [0.69]	7.39 [0.69]
Rows / FPI [FPcm]	2 / 15 [6]	2 / 15 [6]	2 / 15 [6]	2 / 15 [6]
Refrigerant Control	TX Valves	TX Valves	TX Valves	TX Valves
Drain Connection No./Size in. [mm]	1/1 [25.4]	1/1 [25.4]	1/1 [25.4]	1/1 [25.4]
<b>Outdoor Fan - Type</b>				
No. Used/Diameter in. [mm]	Propeller 1/22 [558.8]	Propeller 1/22 [558.8]	Propeller 1/22 [558.8]	Propeller 1/22 [558.8]
Drive Type/No. Speeds	Direct/1	Direct/1	Direct/1	Direct/1
CFM [L/s]	3300 [1557]	3300 [1557]	3000 [1416]	3000 [1416]
No. Motors/HP	1 at 1/3 HP	1 at 1/3 HP	1 at 1/3 HP	1 at 1/3 HP
Motor RPM	1075	1075	1075	1075
<b>Indoor Fan - Type</b>				
No. Used/Diameter in. [mm]	FC Centrifugal 1/10x9 [254x228.6]	FC Centrifugal 1/10x9 [254x228.6]	FC Centrifugal 1/10x9 [254x228.6]	FC Centrifugal 1/10x9 [254x228.6]
Drive Type/No. Speeds	Direct/2	Direct/2	Direct/2	Direct/2
No. Motors	1	1	1	1
Motor HP	3/4	3/4	3/4	3/4
Motor RPM	1075	1075	1075	1075
Motor Frame Size	48	48	48	48
<b>Filter - Type</b>				
Furnished	Field Supplied	Field Supplied	Field Supplied	Field Supplied
(NO.) Size Recommended in. [mm x mm x mm]	No (1)1x24x24 [25x610x610]	No (1)1x24x24 [25x610x610]	No (1)1x24x24 [25x610x610]	No (1)1x24x24 [25x610x610]
<b>Refrigerant Charge Oz. [g]</b>				
	176 [4990]	176 [4990]	183 [5188]	183 [5188]
<b>Weights</b>				
Net Weight lbs. [kg]	508 [230]	505 [229]	500 [227]	510 [231]
Ship Weight lbs. [kg]	519 [235]	516 [234]	511 [232]	521 [236]

### NOTES:

- Cooling Performance is rated at 95° F ambient, 80° F entering dry bulb, 67° F entering wet bulb. Gross capacity does not include the effect of fan motor heat. ARI capacity is net and includes the effect of fan motor heat. Units are suitable for operation to ±20% of nominal cfm. Units are certified in accordance with the Unitary Air Conditioner Equipment certification program, which is based on ARI Standard 210/240 or 360.
- EER and/or SEER are rated at ARI conditions and in accordance with DOE test procedures.
- Outdoor Sound Rating shown is tested in accordance with ARI Standard 270.

# GENERAL DATA - RQPL- MODELS

## NOMINAL SIZES 2-4 TONS [7.1-14.6 kW]

Model RQPL- Series	B024JK	B025JK	B030JK	B036CK
Cooling Performance <sup>1</sup>				Continued ->
Gross Cooling Capacity Btu [kW]	25,000 [7.32]	24,400 [7.15]	29,800 [8.73]	36,600 [10.72]
EER/SEER <sup>2</sup>	11.8/14	12/14	12/14	11.3/14
Nominal CFM/AHRI Rated CFM [L/s]	800/850 [378/401]	800/850 [378/401]	1000/1050 [472/495]	1200/1250 [566/590]
AHRI Net Cooling Capacity Btu [kW]	24,400 [7.15]	23,800 [6.97]	29,200 [8.56]	36,000 [10.55]
Net Sensible Capacity Btu [kW]	18,800 [5.51]	17,800 [5.22]	23,000 [6.74]	27,100 [7.94]
Net Latent Capacity Btu [kW]	5,600 [1.64]	6,000 [1.76]	6,200 [1.82]	8,900 [2.61]
Net System Power kW	2.07	1.95	2.48	3
Heating Performance (Heat Pumps)				
High Temp. Btuh [kW] Rating	23,800 [6.97]	23,600 [6.91]	27,800 [8.15]	33,200 [9.73]
System Power KW / COP	1.99/3.5	1.87/3.7	2.26/3.6	2.7/3.6
Low Temp. Btuh [kW] Rating	13,800 [4.04]	12,900 [3.78]	15,500 [4.54]	18,000 [5.27]
System Power KW / COP	1.84/2.2	1.69/2.24	2.06/2.2	2.4/2.2
HSPF (Btu/Watts-hr)	8	8	8	8
Compressor				
No./Type	1/Scroll	1/Scroll	1/Scroll	1/Scroll
Outdoor Sound Rating (dB) <sup>5</sup>	76	76	76	76
Outdoor Coil - Fin Type				
Tube Type	Louvered	Louvered	Louvered	Louvered
Tube Size in. [mm] OD	Rifled	Rifled	Rifled	Rifled
Face Area sq. ft. [sq. m]	0.375 [9.5]	0.375 [9.5]	0.375 [9.5]	0.375 [9.5]
Rows / FPI [FPcm]	14.51 [1.35]	14.51 [1.35]	16.32 [1.52]	11.2 [1.04]
Refrigerant Control	1 / 22 [9]	1 / 22 [9]	1 / 22 [9]	2 / 22 [9]
TX Valves	TX Valves	TX Valves	TX Valves	TX Valves
Indoor Coil - Fin Type				
Tube Type	Louvered	Louvered	Louvered	Louvered
Tube Size in. [mm]	Rifled	Rifled	Rifled	Rifled
Face Area sq. ft. [sq. m]	0.375 [9.5]	0.375 [9.5]	0.375 [9.5]	0.375 [9.5]
Rows / FPI [FPcm]	5.54 [0.51]	5.54 [0.51]	7.39 [0.69]	7.39 [0.69]
Refrigerant Control	2 / 15 [6]	2 / 15 [6]	2 / 15 [6]	2 / 15 [6]
TX Valves	TX Valves	TX Valves	TX Valves	TX Valves
Drain Connection No./Size in. [mm]	1/1 [25.4]	1/1 [25.4]	1/1 [25.4]	1/1 [25.4]
Outdoor Fan - Type				
No. Used/Diameter in. [mm]	Propeller	Propeller	Propeller	Propeller
Drive Type/No. Speeds	1/22 [558.8]	1/22 [558.8]	1/22 [558.8]	1/22 [558.8]
CFM [L/s]	Direct/1	Direct/1	Direct/1	Direct/1
No. Motors/HP	2700 [1274]	2700 [1274]	2700 [1274]	2700 [1274]
Motor RPM	1 at 1/3 HP	1 at 1/3 HP	1 at 1/3 HP	1 at 1/3 HP
	1075	869	1075	1075
Indoor Fan - Type				
No. Used/Diameter in. [mm]	FC Centrifugal	FC Centrifugal	FC Centrifugal	FC Centrifugal
Drive Type	1/9x7 [229x178]	1/9x7 [229x178]	1/10x9 [254x229]	1/10x9 [254x229]
No. Speeds	Direct	Direct	Direct	Direct
No. Motors	Multiple	Multiple	Multiple	Multiple
Motor HP	1	1	1	1
Motor RPM	1/3	1/3	1/2	1/2
Motor Frame Size	1050	1050	1050	1075
	48	48	48	48
Filter - Type				
Furnished	Field Supplied	Field Supplied	Field Supplied	Field Supplied
(NO.) Size Recommended in. [mm x mm x mm]	No	No	No	No
	(1)1x20x20 [25x508x508]	(1)1x20x20 [25x508x508]	(1)1x24x24 [25x610x610]	(1)1x24x24 [25x610x610]
Refrigerant Charge Oz. [g]	98 [2778]	98 [2778]	108 [3062]	146 [4139]
Weights				
Net Weight lbs. [kg]	391 [177]	391 [177]	444 [201]	471 [214]
Ship Weight lbs. [kg]	401 [182]	401 [182]	455 [206]	482 [219]

# GENERAL DATA - RQPL- MODELS

## NOMINAL SIZES 2-4 TONS [7.1-14.6 kW]

Model RQPL- Series	B036JK	B042CK	B042JK	B048CK
Cooling Performance <sup>1</sup>				Continued ->
Gross Cooling Capacity Btu [kW]	36,600 [10.72]	43,500 [12.75]	43,500 [12.75]	49,000 [14.36]
EER/SEER <sup>2</sup>	11.3/14	11.3/14	11.3/14	11.5/14
Nominal CFM/AHRI Rated CFM [L/s]	1200/1250 [566/590]	1400/1400 [661/661]	1400/1400 [661/661]	1600/1600 [755/755]
AHRI Net Cooling Capacity Btu [kW]	36,000 [10.55]	42,500 [12.45]	42,500 [12.45]	47,500 [13.92]
Net Sensible Capacity Btu [kW]	27,100 [7.94]	31,650 [9.27]	31,650 [9.27]	35,850 [10.5]
Net Latent Capacity Btu [kW]	8,900 [2.61]	10,850 [3.18]	10,850 [3.18]	11,650 [3.41]
Net System Power kW	3	3.76	3.76	4.13
Heating Performance (Heat Pumps)				
High Temp. Btuh [kW] Rating	33,200 [9.73]	41,500 [12.16]	41,500 [12.16]	46,000 [13.48]
System Power KW / COP	2.7/3.6	3.58/3.4	3.58/3.4	3.92/3.44
Low Temp. Btuh [kW] Rating	18,000 [5.27]	24,200 [7.09]	24,200 [7.09]	26,600 [7.79]
System Power KW / COP	2.4/2.2	3.41/2.08	3.41/2.08	3.54/2.2
HSPF (Btu/Watts-hr)	8	8	8	8
Compressor				
No./Type	1/Scroll	1/Scroll	1/Scroll	1/Scroll
Outdoor Sound Rating (dB) <sup>5</sup>	76	76	76	78
Outdoor Coil - Fin Type				
Tube Type	Rifled	Rifled	Rifled	Rifled
Tube Size in. [mm] OD	0.375 [9.5]	0.375 [9.5]	0.375 [9.5]	0.375 [9.5]
Face Area sq. ft. [sq. m]	11.2 [1.04]	16.32 [1.52]	16.32 [1.52]	16.32 [1.52]
Rows / FPI [FPcm]	2 / 22 [9]	2 / 22 [9]	2 / 22 [9]	2 / 22 [9]
Refrigerant Control	TX Valves	TX Valves	TX Valves	TX Valves
Indoor Coil - Fin Type				
Tube Type	Rifled	Rifled	Rifled	Rifled
Tube Size in. [mm]	0.375 [9.5]	0.375 [9.5]	0.375 [9.5]	0.375 [9.5]
Face Area sq. ft. [sq. m]	7.39 [0.69]	7.39 [0.69]	7.39 [0.69]	7.39 [0.69]
Rows / FPI [FPcm]	2 / 15 [6]	2 / 15 [6]	2 / 15 [6]	2 / 15 [6]
Refrigerant Control	TX Valves	TX Valves	TX Valves	TX Valves
Drain Connection No./Size in. [mm]	1/1 [25.4]	1/1 [25.4]	1/1 [25.4]	1/1 [25.4]
Outdoor Fan - Type				
No. Used/Diameter in. [mm]	1/22 [558.8]	1/22 [558.8]	1/22 [558.8]	1/22 [558.8]
Drive Type/No. Speeds	Direct/1	Direct/1	Direct/1	Direct/1
CFM [L/s]	2700 [1274]	3300 [1557]	3300 [1557]	3000 [1416]
No. Motors/HP	1 at 1/3 HP	1 at 1/3 HP	1 at 1/3 HP	1 at 1/3 HP
Motor RPM	1075	1075	1075	1075
Indoor Fan - Type				
No. Used/Diameter in. [mm]	1/10x9 [254x229]	1/10x9 [254x229]	1/10x9 [254x229]	1/10x9 [254x229]
Drive Type	Direct	Direct	Direct	Direct
No. Speeds	Multiple	Multiple	Multiple	Multiple
No. Motors	1	1	1	1
Motor HP	1/2	3/4	3/4	3/4
Motor RPM	1050	1075	1075	1075
Motor Frame Size	48	48	48	48
Filter - Type				
Furnished	No	No	No	No
(NO.) Size Recommended in. [mm x mm x mm]	(1)1x24x24 [25x610x610]	(1)1x24x24 [25x610x610]	(1)1x24x24 [25x610x610]	(1)1x24x24 [25x610x610]
Refrigerant Charge Oz. [g]	146 [4139]	176 [4990]	176 [4990]	183 [5188]
Weights				
Net Weight lbs. [kg]	468 [212]	508 [230]	505 [229]	500 [227]
Ship Weight lbs. [kg]	479 [217]	519 [235]	516 [234]	511 [232]

# GENERAL DATA - RQPL- MODELS

## NOMINAL SIZES 2-4 TONS [7.1-14.6 kW]

Model RQPL- Series	B048JK
<b>Cooling Performance<sup>1</sup></b>	
Gross Cooling Capacity Btu [kW]	49,000 [14.36]
EER/SEER <sup>2</sup>	11.5/14
Nominal CFM/AHRI Rated CFM [L/s]	1600/1600 [755/755]
AHRI Net Cooling Capacity Btu [kW]	47,500 [13.92]
Net Sensible Capacity Btu [kW]	35,850 [10.5]
Net Latent Capacity Btu [kW]	11,650 [3.41]
Net System Power kW	4.13
<b>Heating Performance (Heat Pumps)</b>	
High Temp. Btuh [kW] Rating	46,000 [13.48]
System Power KW / COP	3.92/3.44
Low Temp. Btuh [kW] Rating	26,600 [7.79]
System Power KW / COP	3.54/2.2
HSPF (Btu/Watts-hr)	8
<b>Compressor</b>	
No./Type	1/Scroll
Outdoor Sound Rating (dB) <sup>5</sup>	78
Outdoor Coil - Fin Type	Louvered
Tube Type	Rifled
Tube Size in. [mm] OD	0.375 [9.5]
Face Area sq. ft. [sq. m]	16.32 [1.52]
Rows / FPI [FPcm]	2 / 22 [9]
Refrigerant Control	TX Valves
Indoor Coil - Fin Type	Louvered
Tube Type	Rifled
Tube Size in. [mm]	0.375 [9.5]
Face Area sq. ft. [sq. m]	7.39 [0.69]
Rows / FPI [FPcm]	2 / 15 [6]
Refrigerant Control	TX Valves
Drain Connection No./Size in. [mm]	1/1 [25.4]
Outdoor Fan - Type	Propeller
No. Used/Diameter in. [mm]	1/22 [558.8]
Drive Type/No. Speeds	Direct/1
CFM [L/s]	3000 [1416]
No. Motors/HP	1 at 1/3 HP
Motor RPM	1075
Indoor Fan - Type	FC Centrifugal
No. Used/Diameter in. [mm]	1/10x9 [254x229]
Drive Type	Direct
No. Speeds	Multiple
No. Motors	1
Motor HP	3/4
Motor RPM	1075
Motor Frame Size	48
Filter - Type	Field Supplied
Furnished	No
(NO.) Size Recommended in. [mm x mm x mm]	(1)1x24x24 [25x610x610]
Refrigerant Charge Oz. [g]	183 [5188]
<b>Weights</b>	
Net Weight lbs. [kg]	510 [231]
Ship Weight lbs. [kg]	521 [236]

### NOTES:

- Cooling Performance is rated at 95° F ambient, 80° F entering dry bulb, 67° F entering wet bulb. Gross capacity does not include the effect of fan motor heat. ARI capacity is net and includes the effect of fan motor heat. Units are suitable for operation to ±20% of nominal cfm. Units are certified in accordance with the Unitary Air Conditioner Equipment certification program, which is based on ARI Standard 210/240 or 360.
- EER and/or SEER are rated at ARI conditions and in accordance with DOE test procedures.
- Heating Performance limit settings and rating data were established and approved under laboratory test conditions using American National Standard Institute standards. Ratings shown are for elevations up to 2000 feet. For elevations above 2000 feet, ratings should be reduced at the rate of 4% for each 1000 feet above sea level.
- Outdoor Sound Rating shown is tested in accordance with ARI Standard 270.



# XX. MISCELLANEOUS

ELECTRICAL DATA – RQNL- SERIES									
		-B024JK	-B030JK	-B036CK	-B036JK	-B042CK	-B042JK	-B048CK	-B048JK
Unit Information	Unit Operating Voltage Range	187-253	187-253	187-253	187-253	187-253	187-253	187-253	187-253
	Minimum Circuit Ampacity	21/21	24/24	19/19	27/27	25/25	33/33	26/26	37/37
	Minimum Overcurrent Protection Device Size	25/25	25/25	20/20	25/25	30/30	35/35	30/30	40/40
	Maximum Overcurrent Protection Device Size	30/30	35/35	25/25	40/40	35/35	50/50	35/35	50/50
Compressor Motor	No.	1	1	1	1	1	1	1	1
	Volts	208/230	208/230	208/230	208/230	208/230	208/230	208/230	208/230
	Phase	1	1	3	1	3	1	3	1
	HP	2	2 1/2	3	3	3 1/2	3 1/2	4	4
	RPM	3450	3450	3450	3450	3450	3450	3450	3450
	Amps (RLA), Comp. 1	12.8/12.8	14.1/14.1	10.3/10.3	16.7/16.7	13.1/13.1	19.9/19.9	13.7/13.7	23.8/23.8
	Amps (LRA), Comp 2	58.3/58.3	73/73	73/73	79/79	83.1/83.1	109/109	83.1/83.1	117/117
Condenser Motor	No.	1	1	1	1	1	1	1	1
	Volts	208/230	208/230	208/230	208/230	208/230	208/230	208/230	208/230
	Phase	1	1	1	1	1	1	1	1
	HP	1/5	1/5	1/5	1/5	1/3	1/3	1/3	1/3
	Amps (FLA, each)	1.3	1.3	1.3	1.3	2	2	2	2
	Amps (LRA, each)	2.2	2.2	2.2	2.2	3.9	3.9	3.9	3.9
Evaporator Fan	No.	1	1	1	1	1	1	1	1
	Volts	208/230	208/230	208/230	208/230	208/230	208/230	208/230	208/230
	Phase	1	1	1	1	1	1	1	1
	HP	1/4	1/2	1/2	1/3	3/4	3/4	3/4	3/4
	Amps (FLA, each)	2.8	4.1	4.1	4.1	6	6	6	6
	Amps (LRA, each)	0	0	0	0	0	0	0	0

1. Horsepower Per Compressor.
2. Amp Draw Per Motor. Multiply Value By Number of Motors to Determine Total Amps.

## ELECTRICAL DATA – RQPL- SERIES

		-B024JK	-B025JK	-B030JK	-B036CK	-B036JK	-B042CK	-B042JK	-B048CK	-B048JK
Unit Information	Unit Operating Voltage Range	187-253	187-253	187-253	187-253	187-253	187-253	187-253	187-253	187-253
	Minimum Circuit Ampacity	21/21	21/21	24/24	19/19	27/27	25/25	33/33	26/26	37/37
	Minimum Overcurrent Protection Device Size	25/25	25/25	25/25	20/20	30/30	30/30	35/35	30/30	40/40
	Maximum Overcurrent Protection Device Size	30/30	30/30	35/35	25/25	40/40	35/35	50/50	35/35	50/50
Compressor Motor	No.	1	1	1	1	1	1	1	1	1
	Volts	208/230	208/230	208/230	208/230	208/230	208/230	208/230	208/230	208/230
	Phase	1	1	1	3	1	3	1	3	1
	HP	2	2	2 1/2	3	3	3 1/2	3 1/2	4	4
	RPM	3450	3450	3450	3450	3450	3450	3450	3450	3450
	Amps (RLA), Comp. 1	12.8/12.8	12.8/12.8	14.1/14.1	10.4/10.4	16.7/16.7	13.1/13.1	19.9/19.9	13.7/13.7	23.8/23.8
	Amps (LRA), Comp 2	58.3/58.3	58.3/58.3	73/73	73/73	79/79	83.1/83.1	109/109	83.1/83.1	117/117
Condenser Motor	No.	1	1	1	1	1	1	1	1	1
	Volts	208/230	208/230	208/230	208/230	208/230	208/230	208/230	208/230	208/230
	Phase	1	1	1	1	1	1	1	1	1
	HP	1/5	1/3	1/5	1/5	1/5	1/3	1/3	1/3	1/3
	Amps (FLA, each)	1.3	1.3	1.3	1.3	1.3	2	2	2	2
	Amps (LRA, each)	2.2	2.2	2.2	2.2	2.2	3.9	3.9	3.9	3.9
Evaporator Fan	No.	1	1	1	1	1	1	1	1	1
	Volts	208/230	208/230	208/230	208/230	208/230	208/230	208/230	208/230	208/230
	Phase	1	1	1	1	1	1	1	1	1
	HP	1/3	1/3	1/2	1/2	1/2	3/4	3/4	3/4	3/4
	Amps (FLA, each)	2.8	2.8	4.1	4.1	4.1	6	6	6	6
	Amps (LRA, each)	0	0/0	0	0	0	0	0	0	0

1. Horsepower Per Compressor.
2. Amp Draw Per Motor. Multiply Value By Number of Motors to Determine Total Amps.

# INDOOR AIRFLOW PERFORMANCE FOR 2-4 TON PACKAGE HEAT PUMP – RQNL-DIRECT DRIVE

## RQNL Indoor Airflow Performance - 208 Volts

Nominal Cooling Capacity Tons [kW]	Motor Speed from Factory	Manufacturer Recommended Airflow (Min/Max)	Blower Size/ Motor HP [W] & # of Speeds	Motor Speed	External Static Pressure - Inches W.C. [kPa] (Side Discharge-Wet Coil)									
					0.1 [0.02]	0.2 [0.05]	0.3 [0.07]	0.4 [1.0]	0.5 [1.12]	0.6 [1.15]	0.7 [1.17]			
2.0 [7.03]	High	700 CFM / 900 CFM	9 x 7 Blower 1/4 HP [186W] 2 Speed PSC Motor	Low	CFM [l/s]	675 [319]	657 [310]	634 [299]	602 [284]	560 [264]	505 [238]	435 [205]		
					RPM	695	785	870	905	940	980	1020		
					Watts	221	214	203	191	171	163	149		
2.5 [8.79]	Low	875 CFM / 1125 CFM	10 x 9 Blower 1/2 HP [373W] 3 Speed PSC Motor	Med.	CFM [l/s]	898 [424]	861 [406]	822 [388]	777 [367]	721 [340]	651 [307]	562 [265]		
					RPM	940	965	995	1020	1045	1070	1090		
					Watts	292	278	266	253	239	221	199		
3.0 [10.55]	High	1050 CFM / 1350 CFM	10 x 9 Blower 1/3 HP [249W] 1 Speed PSC Motor	High	CFM [l/s]	1076 [508]	1059 [500]	1032 [487]	996 [470]	950 [448]	896 [423]	832 [393]		
					RPM	730	775	820	865	905	940	975		
					Watts	356	349	341	331	320	305	287		
3.5 [12.31]	Low (Tap 1)	1225 CFM / 1575 CFM	10 x 9 Blower 3/4 HP [559W] 2 Speed X13 Motor	High	CFM [l/s]	1222 [577]	1197 [565]	1179 [556]	1162 [548]	1137 [537]	1097 [518]	1033 [488]		
					RPM	765	810	855	890	920	960	995		
					Watts	423	415	407	397	386	370	351		
4.0 [14.07]	Low (Tap 1)	1350 CFM / 1700 CFM	10 x 9 Blower 3/4 HP [559W] 2 Speed X13 Motor	High	CFM [l/s]	1514 [715]	1461 [690]	1415 [668]	1370 [647]	1322 [624]	1266 [597]	1197 [565]		
					RPM	895	930	965	985	1005	1025	1045		
					Watts	538	514	493	473	454	434	412		
3.0 [10.55]	High	1050 CFM / 1350 CFM	10 x 9 Blower 1/3 HP [249W] 1 Speed PSC Motor	High	CFM [l/s]	1222 [577]	1201 [567]	1173 [554]	1137 [537]	1090 [514]	1030 [486]	954 [450]		
					RPM	785	805	830	870	905	950	990		
					Watts	355	352	346	340	331	320	306		
3.5 [12.31]	Low (Tap 1)	1225 CFM / 1575 CFM	10 x 9 Blower 3/4 HP [559W] 2 Speed X13 Motor	High	CFM [l/s]	1455 [687]	1431 [675]	1396 [659]	1360 [642]	1315 [621]	1285 [606]	1241 [586]		
					RPM	824	856	889	931	968	1009	1041		
					Watts	268	280	288	303	311	325	331		
4.0 [14.07]	Low (Tap 1)	1350 CFM / 1700 CFM	10 x 9 Blower 3/4 HP [559W] 2 Speed X13 Motor	High	CFM [l/s]	1559 [736]	1530 [722]	1488 [702]	1454 [686]	1417 [669]	1375 [649]	1336 [631]		
					RPM	870	893	932	968	1007	1036	1072		
					Watts	321	327	338	351	364	371	381		
4.0 [14.07]	Low (Tap 1)	1350 CFM / 1700 CFM	10 x 9 Blower 3/4 HP [559W] 2 Speed X13 Motor	High	CFM [l/s]	1675 [791]	1658 [782]	1610 [760]	1580 [746]	1535 [724]	1491 [704]	1422 [671]		
					RPM	923	944	979	1013	1045	1077	1098		
					Watts	390	401	412	425	433	440	432		
4.0 [14.07]	Low (Tap 2)	1350 CFM / 1700 CFM	10 x 9 Blower 3/4 HP [559W] 2 Speed X13 Motor	High	CFM [l/s]	1770 [835]	1751 [826]	1706 [805]	1672 [789]	1624 [766]	1555 [734]	1463 [690]		
					RPM	966	989	1018	1050	1078	1100	1115		
					Watts	454	466	473	486	490	481	460		

Notes:  
 Italic type indicates airflow outside of manufacturers recommendation.  
 Do not connect wiring to unspecified speed taps.

Down Discharge Pressure Drop (Add to Side Discharge External Static Pressure)									
CFM [L/s]	600 [283]	800 [378]	1000 [472]	1200 [566]	1400 [661]	1600 [755]	1800 [849]	2000 [944]	
Pressure Drop - Inches W.C. [kPa]	0	.02 [0.005]	.05 [0.012]	.07 [0.017]	.1 [0.025]	.12 [0.030]	.15 [0.037]	.17 [0.042]	

# INDOOR AIRFLOW PERFORMANCE FOR 2-4 TON PACKAGE HEAT PUMP – RQNL- DIRECT DRIVE

## RQNL Indoor Airflow Performance - 230 Volts

Nominal Cooling Capacity Tons [kW]	Motor Speed from Factory	Manufacturer Recommended Airflow (Min/Max)	Blower Size/ Motor HP [W] & # of Speeds	Motor Speed	External Static Pressure - Inches W.C. [kPa] (Side Discharge-Wet Coil)							
					0.1 [.02]	0.2 [.05]	0.3 [.07]	0.4 [.10]	0.5 [.12]	0.6 [.15]	0.7 [.17]	
2.0 [7.03]	High	700 CFM / 900 CFM	9 x 7 Blower 1/4 HP [186W] 2 Speed PSC Motor	Low	CFM [l/s]	771 [364]	751 [354]	725 [342]	691 [326]	645 [304]	584 [276]	546 [258]
					RPM	825	870	910	950	985	1010	1030
					Watts	253	242	230	217	204	189	181
2.5 [8.79]	Low	875 CFM / 1125 CFM	10 x 9 Blower 1/2 HP [373W] 3 Speed PSC Motor	High	CFM [l/s]	946 [446]	922 [435]	882 [416]	830 [392]	769 [363]	701 [331]	630 [297]
					RPM	990	1015	1035	1055	1070	1085	1100
					Watts	315	303	288	273	257	241	226
2.5 [8.79]	Low	875 CFM / 1125 CFM	10 x 9 Blower 1/2 HP [373W] 3 Speed PSC Motor	Low	CFM [l/s]	1206 [569]	1182 [558]	1157 [546]	1128 [532]	1091 [515]	1044 [493]	983 [464]
					RPM	760	815	870	910	950	975	1000
					Watts	419	406	394	381	368	353	334
3.0 [10.55]	High	1050 CFM / 1350 CFM	10 x 9 Blower 1/3 HP [249W] 1 Speed PSC Motor	Med.	CFM [l/s]	1411 [666]	1368 [646]	1327 [626]	1285 [606]	1238 [584]	1183 [558]	1116 [527]
					RPM	865	900	935	970	1000	1020	1035
					Watts	498	498	481	464	447	431	391
3.5 [12.31]	Low (Tap 1)	1225 CFM / 1575 CFM	10 x 9 Blower 3/4 HP [559W] 2 Speed X13 Motor	High	CFM [l/s]	1641 [774]	1577 [744]	1515 [715]	1455 [687]	1393 [657]	1329 [627]	1262 [596]
					RPM	980	1000	1020	1035	1050	1065	1080
					Watts	589	565	543	523	503	481	456
4.0 [14.07]	Low (Tap 1)	1350 CFM / 1700 CFM	10 x 9 Blower 3/4 HP [559W] 2 Speed X13 Motor	High	CFM [l/s]	1391 [656]	1357 [640]	1312 [619]	1258 [594]	1201 [567]	1145 [540]	1093 [516]
					RPM	835	875	915	940	965	985	1000
					Watts	428	419	406	392	378	365	355
4.0 [14.07]	Low (Tap 1)	1350 CFM / 1700 CFM	10 x 9 Blower 3/4 HP [559W] 2 Speed X13 Motor	High	CFM [l/s]	1467 [692]	1439 [679]	1408 [665]	1360 [642]	1331 [628]	1287 [607]	1259 [594]
					RPM	831	854	894	932	972	1005	1042
					Watts	276	282	297	307	319	326	341
4.0 [14.07]	Low (Tap 1)	1350 CFM / 1700 CFM	10 x 9 Blower 3/4 HP [559W] 2 Speed X13 Motor	High (Tap 2)	CFM [l/s]	1550 [732]	1520 [717]	1486 [701]	1449 [684]	1407 [664]	1382 [652]	1337 [631]
					RPM	867	890	930	974	1003	1039	1073
					Watts	317	323	339	355	362	377	385
4.0 [14.07]	Low (Tap 1)	1350 CFM / 1700 CFM	10 x 9 Blower 3/4 HP [559W] 2 Speed X13 Motor	Low (Tap 1)	CFM [l/s]	1692 [799]	1661 [784]	1633 [771]	1589 [750]	1560 [736]	1512 [714]	1442 [681]
					RPM	931	950	982	1018	1054	1082	1103
					Watts	404	409	424	434	450	453	443
4.0 [14.07]	Low (Tap 1)	1350 CFM / 1700 CFM	10 x 9 Blower 3/4 HP [559W] 2 Speed X13 Motor	High (Tap 2)	CFM [l/s]	1748 [825]	1718 [811]	1686 [796]	1647 [777]	1616 [763]	1543 [728]	1472 [695]
					RPM	955	978	1010	1043	1073	1096	1111
					Watts	440	446	462	475	484	473	459

**Notes:**

Italic type indicates airflow outside of manufacturers recommendation.  
Do not connect wiring to unspecified speed taps.

**Down Discharge Pressure Drop (Add to External Static Pressure)**

CFM [l/s]	600 [283]	800 [378]	1000 [472]	1200 [566]	1400 [661]	1600 [755]	1800 [849]	2000 [944]
Pressure Drop - Inches W.C. [kPa]	0	.02 [0.005]	.05 [0.012]	.07 [0.017]	.1 [0.025]	.12 [0.030]	.15 [0.037]	.17 [0.042]

# INDOOR AIRFLOW PERFORMANCE FOR 2-4 TON PACKAGE HEAT PUMP – RQPL- DIRECT DRIVE

## RQPL Indoor Airflow Performance - 208 Volts

Nominal Cooling Capacity Tons [kW]	Motor Speed from Factory	Manufacturer Recommended Airflow (Min/Max)	Blower Size/Motor HP [W] & # of Speeds	Motor Speed	External Static Pressure - Inches W.C. [kPa] (Side Discharge-Wet Coil)									
					0.1 [1.02]	0.2 [1.05]	0.3 [1.07]	0.4 [1.10]	0.5 [1.12]	0.6 [1.15]	0.7 [1.17]	0.8 [1.20]		
2.0 [7.03]	Low (Tap 1)	700 CFM / 900 CFM	9 x 7 Blower 1/3 HP [249W] 3 Speed X13 Motor	Low (Tap 1)	CFM [l/s]	847 [400]	818 [386]	788 [372]	765 [361]	737 [348]	695 [328]	659 [311]	581 [274]	
					RPM	862	888	940	976	1033	1066	1122	1193	
					Watts	145	147	156	157	164	167	167	155	
	High (Tap 2)	CFM [l/s]	914 [431]	887 [419]	853 [403]	824 [389]	793 [374]	762 [360]	717 [338]	602 [284]				
		RPM	934	971	1024	1053	1083	1121	1135	1155				
		Watts	173	177	185	186	188	192	185	164				
2.5 [8.79]	Low (Tap 1)	875 CFM / 1125 CFM	10 x 9 Blower 1/2 HP [373W] 3 Speed X13 Motor	Low (Tap 1)	CFM [l/s]	1067 [504]	1034 [488]	992 [468]	957 [452]	912 [430]	820 [387]	778 [367]	729 [344]	
					RPM	719	749	791	819	876	952	983	1024	
					Watts	143	145	155	159	169	182	185	192	
					CFM [l/s]	1165 [550]	1132 [534]	1091 [515]	1051 [496]	1009 [476]	959 [453]	855 [404]	819 [387]	
					RPM	744	785	833	864	905	951	1020	1053	
					Watts	167	177	188	191	202	206	217	351	
	High (Tap 3)	CFM [l/s]	1252 [591]	1213 [572]	1166 [550]	1137 [537]	1099 [519]	1046 [494]	986 [465]	892 [421]				
		RPM	796	826	868	893	934	982	1026	1086				
		Watts	206	210	219	225	234	245	248	256				
		CFM [l/s]	1247 [589]	1220 [576]	1178 [556]	1143 [539]	1099 [519]	1064 [502]	998 [471]	904 [427]				
		RPM	784	819	863	890	932	957	1012	1075				
		Watts	200	208	219	224	233	236	246	256				
3.0 [10.55]	Low (Tap 1)	1050 CFM / 1350 CFM	10 x 9 Blower 1/2 HP [373W] 3 Speed X13 Motor	Med. (Tap 2)	CFM [l/s]	1307 [617]	1292 [610]	1238 [584]	1214 [573]	1170 [552]	1135 [536]	1087 [513]	989 [467]	
					RPM	820	850	889	918	944	981	1028	1087	
					Watts	233	242	248	255	262	268	277	284	
					CFM [l/s]	1396 [659]	1357 [640]	1334 [630]	1286 [607]	1253 [591]	1207 [570]	1163 [549]	1103 [521]	
					RPM	864	898	920	942	976	1010	1043	1089	
					Watts	268	280	288	292	299	304	310	316	
	High (Tap 2)	CFM [l/s]	1455 [687]	1431 [675]	1396 [659]	1360 [642]	1315 [621]	1285 [606]	1241 [586]					
		RPM	824	856	889	931	968	1009	1041					
		Watts	268	280	288	303	311	325	331					
		CFM [l/s]	1559 [736]	1530 [722]	1488 [702]	1454 [686]	1417 [669]	1375 [649]	1336 [631]					
		RPM	870	893	932	968	1007	1036	1072					
		Watts	321	327	338	351	364	371	381					
3.5 [12.31]	Low (Tap 1)	1225 CFM / 1575 CFM	10 x 9 Blower 3/4 HP [559W] 2 Speed X13 Motor	Low (Tap 1)	CFM [l/s]	1675 [791]	1658 [782]	1610 [760]	1580 [746]	1535 [724]	1491 [704]	1422 [671]		
					RPM	923	944	979	1013	1045	1077	1098		
					Watts	390	401	412	425	433	440	432		
					CFM [l/s]	1770 [835]	1751 [826]	1706 [805]	1672 [789]	1624 [766]	1555 [734]	1463 [690]		
					RPM	966	989	1018	1050	1078	1100	1115		
					Watts	454	466	473	486	490	481	460		
	High (Tap 2)	CFM [l/s]	1675 [791]	1658 [782]	1610 [760]	1580 [746]	1535 [724]	1491 [704]	1422 [671]					
		RPM	923	944	979	1013	1045	1077	1098					
		Watts	390	401	412	425	433	440	432					
		CFM [l/s]	1770 [835]	1751 [826]	1706 [805]	1672 [789]	1624 [766]	1555 [734]	1463 [690]					
		RPM	966	989	1018	1050	1078	1100	1115					
		Watts	454	466	473	486	490	481	460					

Notes:  
 Italic type indicates airflow outside of manufacturer's recommendation.  
 Do not connect wiring to unspecified speed taps.

Down Discharge Pressure Drop (Add to Side Discharge External Static Pressure)	
CFM [l/s]	600 [283]
Pressure Drop - Inches W.C. [kPa]	0
	.05 [1.012]
	.07 [1.017]
	.1 [1.025]
	.12 [1.030]
	.15 [1.037]
	.17 [1.042]
	.2000 [944]

# INDOOR AIRFLOW PERFORMANCE FOR 2-4 TON PACKAGE HEAT PUMP – RQPL-DIRECT DRIVE

<b>RQPL Indoor Airflow Performance - 230 Volts</b>													
Nominal Cooling Capacity Tons [kW]	Motor Speed from Factory	Manufacturer Recommended Airflow (Min/Max)	Blower Size/ Motor HP [W] & # of Speeds	Motor Speed	External Static Pressure - Inches W.C. [kPa] (Side Discharge-Wet Coil)								
					0.1 [0.02]	0.2 [0.05]	0.3 [0.07]	0.4 [0.10]	0.5 [0.12]	0.6 [0.15]	0.7 [0.17]	0.8 [0.20]	
2.0 [7.03]	Low (Tap 1)	700 CFM / 900 CFM	9 x 7 Blower 1/3 HP [249W] 3 Speed X13 Motor	Low (Tap 1)	CFM [l/s]	862 [407]	834 [394]	819 [387]	781 [369]	761 [359]	729 [344]	695 [328]	606 [286]
					Watts	889	953	974	1018	1065	1101	1133	1156
					RPM	151	159	162	166	173	176	180	165
	High (Tap 2)	900 CFM	X13 Motor	High (Tap 2)	CFM [l/s]	918 [433]	888 [419]	874 [412]	838 [395]	819 [387]	781 [369]	711 [336]	616 [291]
					Watts	953	988	1032	1060	1091	1126	1146	1157
					RPM	181	184	194	198	200	204	189	168
2.5 [8.79]	Low (Tap 1)	875 CFM / 1125 CFM	10 x 9 Blower 1/2 HP [373W] 3 Speed X13 Motor	Low (Tap 1)	CFM [l/s]	1076 [508]	1041 [491]	1017 [480]	970 [458]	928 [438]	852 [402]	785 [370]	745 [352]
					Watts	715	753	787	825	877	946	1005	1032
					RPM	144	148	157	169	175	187	198	202
	Med. (Tap 2)	1125 CFM	X13 Motor	Med. (Tap 2)	CFM [l/s]	1187 [560]	1124 [530]	1096 [517]	1071 [505]	1024 [483]	987 [466]	896 [423]	852 [402]
					Watts	762	799	832	859	914	940	1021	1059
					RPM	176	182	191	196	209	212	227	235
High (Tap 3)	1350 CFM	X13 Motor	High (Tap 3)	CFM [l/s]	1271 [600]	1223 [577]	1169 [552]	1137 [537]	1104 [521]	1071 [505]	1015 [479]	934 [441]	
				Watts	797	836	878	905	939	974	1026	1089	
				RPM	212	217	227	231	241	247	257	270	
3.0 [10.55]	Low (Tap 1)	1050 CFM / 1350 CFM	10 x 9 Blower 1/2 HP [373W] 3 Speed X13 Motor	Low (Tap 1)	CFM [l/s]	1258 [594]	1215 [573]	1200 [566]	1160 [547]	1130 [533]	1082 [511]	1026 [484]	954 [450]
					Watts	802	829	861	894	933	971	1020	1077
					RPM	210	217	225	230	239	245	259	268
	Med. (Tap 2)	1350 CFM	X13 Motor	Med. (Tap 2)	CFM [l/s]	1336 [631]	1298 [613]	1259 [594]	1229 [580]	1198 [565]	1160 [547]	1116 [527]	1071 [505]
					Watts	821	867	903	920	957	993	1038	1071
					RPM	239	249	259	262	275	279	290	299
High (Tap 3)	1350 CFM	X13 Motor	High (Tap 3)	CFM [l/s]	1416 [668]	1379 [651]	1342 [633]	1292 [610]	1275 [602]	1240 [585]	1200 [566]	1168 [551]	
				Watts	874	898	933	952	993	1011	1060	1091	
				RPM	285	290	299	304	314	322	328	337	
3.5 [12.31]	Low (Tap 1)	1225 CFM / 1575 CFM	10 x 9 Blower 3/4 HP [559W] 2 Speed X13 Motor	Low (Tap 1)	CFM [l/s]	1467 [692]	1439 [679]	1408 [665]	1360 [642]	1331 [628]	1287 [607]	1259 [594]	
					Watts	831	854	894	932	972	1005	1042	
					RPM	276	282	297	307	319	326	341	
	High (Tap 2)	1575 CFM	X13 Motor	High (Tap 2)	CFM [l/s]	1550 [732]	1520 [717]	1486 [701]	1449 [684]	1407 [664]	1382 [652]	1337 [631]	
					Watts	867	890	930	974	1003	1039	1073	
					RPM	317	323	339	355	362	377	385	
Low (Tap 1)	1700 CFM	X13 Motor	Low (Tap 1)	CFM [l/s]	1692 [799]	1661 [784]	1633 [771]	1589 [750]	1560 [736]	1512 [714]	1442 [681]		
				Watts	931	950	982	1018	1054	1082	1103		
				RPM	404	409	424	434	450	453	443		
High (Tap 2)	1700 CFM	X13 Motor	High (Tap 2)	CFM [l/s]	1748 [825]	1718 [811]	1686 [796]	1647 [777]	1616 [763]	1543 [728]	1472 [695]		
				Watts	955	978	1010	1043	1073	1096	1111		
				RPM	440	446	462	475	484	473	459		

Notes:  
 Italic type indicates airflow outside of manufacturers recommendation.  
 Do not connect wiring to unspecified speed taps.

<b>Down Discharge Pressure Drop (Add to External Static Pressure)</b>	
CFM [l/s]	600 [283]
Pressure Drop - Inches W.C. [kPa]	0

# AUXILIARY HEATER KITS CHARACTERISTICS AND APPLICATION – RQNL-

<b>208/240 VOLT, THREE PHASE, 60 HZ, AUXILIARY ELECTRIC HEATER KITS CHARACTERISTICS AND APPLICATION</b>												
Single Power Supply for Both Unit and Heater Kit						Separate Power Supply For Both Unit and Heater Kit						
Rheem Model Number	RXQJ- Heater Kit Nominal kW	No. of Sequence Steps	Rated Heater kW @ 208/240V	Heater KBTU/Hr @ 208/240 V	Heater Amp. @ 208/240V	Heat Pump			Heater Kit			
						Unit Min. Ckt. Ampacity @ 208/240 V	Over Current Protective Device Size		Min. Ckt. Ampacity 208/240V	Max. Fuse Size 208/240V	Over Current Protective Device Size	
							Min./Max. @ 208 V	Min./Max. @ 240 V			Min./Max. @ 208 V	Min./Max. @ 240 V
RQNL-B036CK	No Heat	—	—	—	—	17/17	20/25	20/25	—	17/17	20/25	20/25
	A10C	1	7.2/9.6	24.56/32.75	20/23.1	42/46	45/45	50/50	25/29	25/30	20/25	20/25
	A15C	1	10.8/14.4	36.84/49.13	30.1/34.7	55/61	60/60	60/60	38/44	40/45	20/25	20/25
RQNL-B042CK	No Heat	—	—	—	—	25/25	30/35	30/35	—	—	30/35	30/35
	A10C	1	7.2/9.6	24.56/32.75	20/23.1	50/54	60/60	60/60	25/29	25/30	30/35	30/35
	A15C	1	10.8/14.4	36.84/49.13	30.1/34.7	63/69	70/70	70/70	38/44	40/45	30/35	30/35
RQNL-B048CK	No Heat	—	—	—	—	26/26	30/35	30/35	—	—	30/35	30/35
	A10C	1	7.2/9.6	24.56/32.75	20/23.1	51/55	60/60	60/60	25/29	25/30	30/35	30/35
	A15C	1	10.8/14.4	36.84/49.13	30.1/34.7	64/70	70/70	80/80	38/44	40/45	30/35	30/35

<b>208/240 VOLT, SINGLE PHASE, 60 HZ, AUXILIARY ELECTRIC HEATER KITS CHARACTERISTICS AND APPLICATION</b>												
Single Power Supply for Both Unit and Heater Kit						Separate Power Supply For Both Unit and Heater Kit						
Rheem Model Number	RXQJ- Heater Kit Nominal kW	No. of Sequence Steps	Rated Heater kW @ 208/240V	Heater KBTU/Hr @ 208/240 V	Heater Amp. @ 208/240V	Heat Pump			Heater Kit			
						Unit Min. Ckt. Ampacity @ 208/240 V	Over Current Protective Device Size		Min. Ckt. Ampacity 208/240V	Max. Fuse Size 208/240V	Over Current Protective Device Size	
							Min./Max. @ 208 V	Min./Max. @ 240 V			Min./Max. @ 208 V	Min./Max. @ 240 V
RQNL-B024JK	No Heat	—	—	—	—	19/19	25/30	25/30	—	—	25/30	25/30
	A05J	1	3.6/4.8	12.28/16.38	17.3/20	41/44	45/45	45/50	22/25	25/25	25/30	25/30
	A10J	1	7.2/9.6	24.56/32.75	34.6/40	63/69	70/70	70/70	44/50	45/50	25/30	25/30
RQNL-B030JK	No Heat	—	—	—	—	22/22	25/35	25/35	—	—	25/35	25/35
	A05J	1	3.6/4.8	12.28/16.38	17.3/20	44/47	45/50	50/50	22/25	25/25	25/35	25/35
	A10J	1	7.2/9.6	24.56/32.75	34.6/40	66/72	70/70	80/80	44/50	45/50	25/35	25/35
RQNL-B036JK	No Heat	—	—	—	—	24/24	25/40	25/40	—	—	25/40	25/40
	B06J	1	4.2/5.6	14.33/19.1	20.2/23.3	50/54	50/60	60/60	26/30	30/30	25/40	25/40
	A10J	1	7.2/9.6	24.56/32.75	34.6/40	68/74	70/70	80/80	44/50	45/50	25/40	25/40
RQNL-B042JK	No Heat	—	—	—	—	89/99	90/90	100/100	65/75	70/80	25/40	25/40
	B06J	1	4.2/5.6	14.33/19.1	20.2/23.3	33/33	35/50	35/50	—	—	35/50	35/50
	B10J	1	7.2/9.6	24.56/32.75	34.6/40	77/83	80/80	90/90	44/50	45/50	35/50	35/50
RQNL-B048JK	No Heat	—	—	—	—	98/108	100/100	110/110	65/75	70/80	35/50	35/50
	B06J	1	4.2/5.6	14.33/19.1	20.2/23.3	37/37	40/50	40/50	—	—	40/50	40/50
	B10J	1	7.2/9.6	24.56/32.75	34.6/40	81/87	90/90	90/100	44/50	45/50	40/50	40/50
RQNL-B048JK	No Heat	—	—	—	—	102/112	110/110	125/125	65/75	70/80	40/50	40/50
	B06J	1	4.2/5.6	14.33/19.1	20.2/23.3	63/67	70/80	70/80	26/30	30/30	40/50	40/50
	B15J	1	10.8/14.4	36.84/49.13	51.9/60	102/112	110/110	125/125	65/75	70/80	40/50	40/50

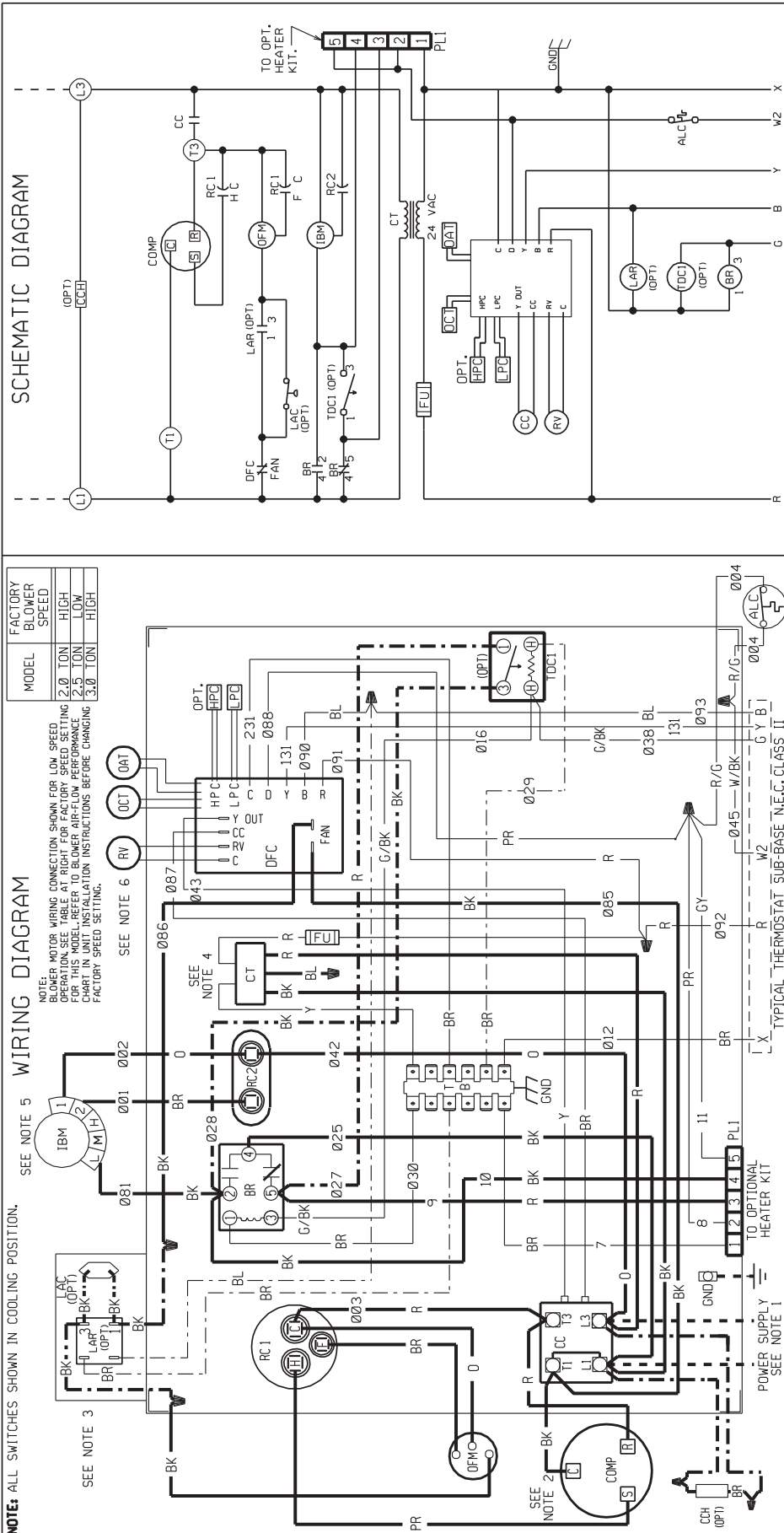
# AUXILIARY HEATER KITS CHARACTERISTICS AND APPLICATION – RQPL-

<b>208/240 VOLT, THREE PHASE, 60 HZ, AUXILIARY ELECTRIC HEATER KITS CHARACTERISTICS AND APPLICATION</b>												
Separate Power Supply For Both Unit And Heater Kit												
Rheem Model Number	Single Power Supply for Both Unit and Heater Kit						Separate Power Supply For Both Unit And Heater Kit					
	Heater Kit			Heat Pump			Heater Kit			Heat Pump		
	RXQJ- Heater Kit Nominal kW	No. of Sequence Steps	Rated Heater kW @ 208/240V	Heater KBTU/Hr @ 208/240 V	Heater Amp. @ 208/240V	Unit Min. Ckt. Ampacity @ 208/240 V	Over Current Protective Device Size Min./Max. @ 208 V	Min. Ckt. Ampacity 208/240V	Max. Fuse Size 208/240V	Min. Circuit Ampacity 208/240V	Over Current Protective Device Size Min./Max. @ 208 V	Min./Max. @ 240 V
RQPL-B036CK	No Heat	—	—	—	—	19/19	20/25	—	—	19/19	20/25	20/25
	A10C	1	7.2/9.6	24.56/32.75	20/23.1	44/48	45/45	25/29	25/30	19/19	20/25	20/25
	A15C	1	10.8/14.4	36.84/49.13	30.1/34.7	57/63	60/60	38/44	40/45	19/19	20/25	20/25
RQPL-B042CK	No Heat	—	—	—	—	25/25	30/35	—	—	25/25	30/35	30/35
	A10C	1	7.2/9.6	24.56/32.75	20/23.1	50/54	60/60	25/29	25/30	25/25	30/35	30/35
	A15C	1	10.8/14.4	36.84/49.13	30.1/34.7	63/69	70/70	38/44	40/45	25/25	30/35	30/35
RQPL-B048CK	No Heat	—	—	—	—	26/26	30/35	—	—	26/26	30/35	30/35
	A10C	1	7.2/9.6	24.56/32.75	20/23.1	51/55	60/60	25/29	25/30	26/26	30/35	30/35
	A15C	1	10.8/14.4	36.84/49.13	30.1/34.7	64/70	70/70	38/44	40/45	26/26	30/35	30/35

<b>208/240 VOLT, SINGLE PHASE, 60 HZ, AUXILIARY ELECTRIC HEATER KITS CHARACTERISTICS AND APPLICATION</b>												
Separate Power Supply For Both Unit And Heater Kit												
Rheem Model Number	Single Power Supply for Both Unit and Heater Kit						Separate Power Supply For Both Unit And Heater Kit					
	Heater Kit			Heat Pump			Heater Kit			Heat Pump		
	RXQJ- Heater Kit Nominal kW	No. of Sequence Steps	Rated Heater kW @ 208/240V	Heater KBTU/Hr @ 208/240 V	Heater Amp. @ 208/240V	Unit Min. Ckt. Ampacity @ 208/240 V	Over Current Protective Device Size Min./Max. @ 208 V	Min. Ckt. Ampacity 208/240V	Max. Fuse Size 208/240V	Min. Circuit Ampacity 208/240V	Over Current Protective Device Size Min./Max. @ 208 V	Min./Max. @ 240 V
RQPL-B024JK	No Heat	—	—	—	—	21/21	25/30	—	—	21/21	25/30	25/30
	A05J	1	3.6/4.8	12.28/16.38	17.3/20	43/46	45/50	22/25	25/25	21/21	25/30	25/30
	A10J	1	7.2/9.6	24.56/32.75	34.6/40	65/71	70/70	44/50	45/50	21/21	25/30	25/30
RQPL-B025JK	No Heat	—	—	—	—	21/21	25/30	—	—	21/21	25/30	25/30
	A05J	1	3.6/4.8	12.28/16.38	17.3/20	43/46	45/50	22/25	25/25	21/21	25/30	25/30
	A10J	1	7.2/9.6	24.56/32.75	34.6/40	65/71	70/70	44/50	45/50	21/21	25/30	25/30
RQPL-B030JK	No Heat	—	—	—	—	24/24	25/35	—	—	24/24	25/35	25/35
	A05J	1	3.6/4.8	12.28/16.38	17.3/20	46/49	50/50	22/25	25/25	24/24	25/35	25/35
	A10J	1	7.2/9.6	24.56/32.75	34.6/40	68/74	70/70	44/50	45/50	24/24	25/35	25/35
RQPL-B036JK	No Heat	—	—	—	—	27/27	30/40	—	—	27/27	30/40	30/40
	B06J	1	4.2/5.6	14.33/19.1	20.2/23.3	53/57	60/60	26/30	30/30	27/27	30/40	30/40
	A10J	1	7.2/9.6	24.56/32.75	34.6/40	71/77	80/80	44/50	45/50	27/27	30/40	30/40
RQPL-B042JK	No Heat	—	—	—	—	92/102	100/100	—	—	27/27	30/40	30/40
	B06J	1	4.2/5.6	14.33/19.1	20.2/23.3	33/33	35/50	—	—	33/33	35/50	35/50
	B10J	1	7.2/9.6	24.56/32.75	34.6/40	59/63	70/70	26/30	30/30	33/33	35/50	35/50
RQPL-B048JK	No Heat	—	—	—	—	98/108	100/100	—	—	33/33	35/50	35/50
	B06J	1	4.2/5.6	14.33/19.1	20.2/23.3	63/67	70/80	26/30	30/30	37/37	40/50	40/50
	B10J	1	7.2/9.6	24.56/32.75	34.6/40	81/87	90/90	44/50	45/50	37/37	40/50	40/50
RQPL-B050JK	No Heat	—	—	—	—	102/112	110/110	—	—	37/37	40/50	40/50
	B06J	1	4.2/5.6	14.33/19.1	20.2/23.3	63/67	70/80	26/30	30/30	37/37	40/50	40/50
	B10J	1	7.2/9.6	24.56/32.75	34.6/40	81/87	90/90	44/50	45/50	37/37	40/50	40/50
RQPL-B055JK	No Heat	—	—	—	—	102/112	110/110	—	—	37/37	40/50	40/50
	B06J	1	4.2/5.6	14.33/19.1	20.2/23.3	63/67	70/80	26/30	30/30	37/37	40/50	40/50
	B10J	1	7.2/9.6	24.56/32.75	34.6/40	81/87	90/90	44/50	45/50	37/37	40/50	40/50



**FIGURE 12**  
**WIRING DIAGRAM**



**SCHEMATIC DIAGRAM**

MODEL	FACTORY BLOWER SPEED
2.0 TON	HIGH
2.5 TON	LOW
3.0 TON	HIGH

**NOTE:** BLOWER MOTOR WIRING CONNECTION SHOWN FOR LOW SPEED. REFER TO THE WIRING DIAGRAM FOR THIS MODEL. REFER TO BLOWER AIR-FLOW PERFORMANCE CHART IN UNIT INSTALLATION INSTRUCTIONS BEFORE CHANGING FACTORY SPEED SETTING.

**WIRING DIAGRAM**

**NOTE:** ALL SWITCHES SHOWN IN COOLING POSITION.

**WIRE COLOR CODE**

BK	BLACK
BR	BROWN
BL	BLUE
G	GREEN
GY	GRAY
0	ORANGE
PR	PURPLE
R	RED
W	WHITE
Y	YELLOW

**ELECTRICAL WIRING DIAGRAM**

**PACKAGE HEAT PUMP**

1 PH, 208-230 VOLT

PSC INDOOR BLOWER MOTOR

DR. BY: \_\_\_\_\_ DATE: 6-17-10

MGR: \_\_\_\_\_

DWG. NO. **90-23621-31**

REV: **03**

**WIRING INFORMATION**

LINE VOLTAGE

- FACTORY STANDARD
- FACTORY OPTION
- FIELD INSTALLED
- LOW VOLTAGE
- FACTORY STANDARD
- FACTORY OPTION
- FIELD INSTALLED

REPLACEMENT WIRE

- MUST BE THE SAME SIZE AND TYPE OF INSULATION AS ORIGINAL (105 C. MIN.)
- WARNING
- CABINET MUST BE PERMANENTLY GROUNDED AND CONFORM TO I.E.C., N.E.C., C.E.C. NATIONAL WIRING REGULATIONS, AND LOCAL CODES AS APPLICABLE.

**NOTES:**

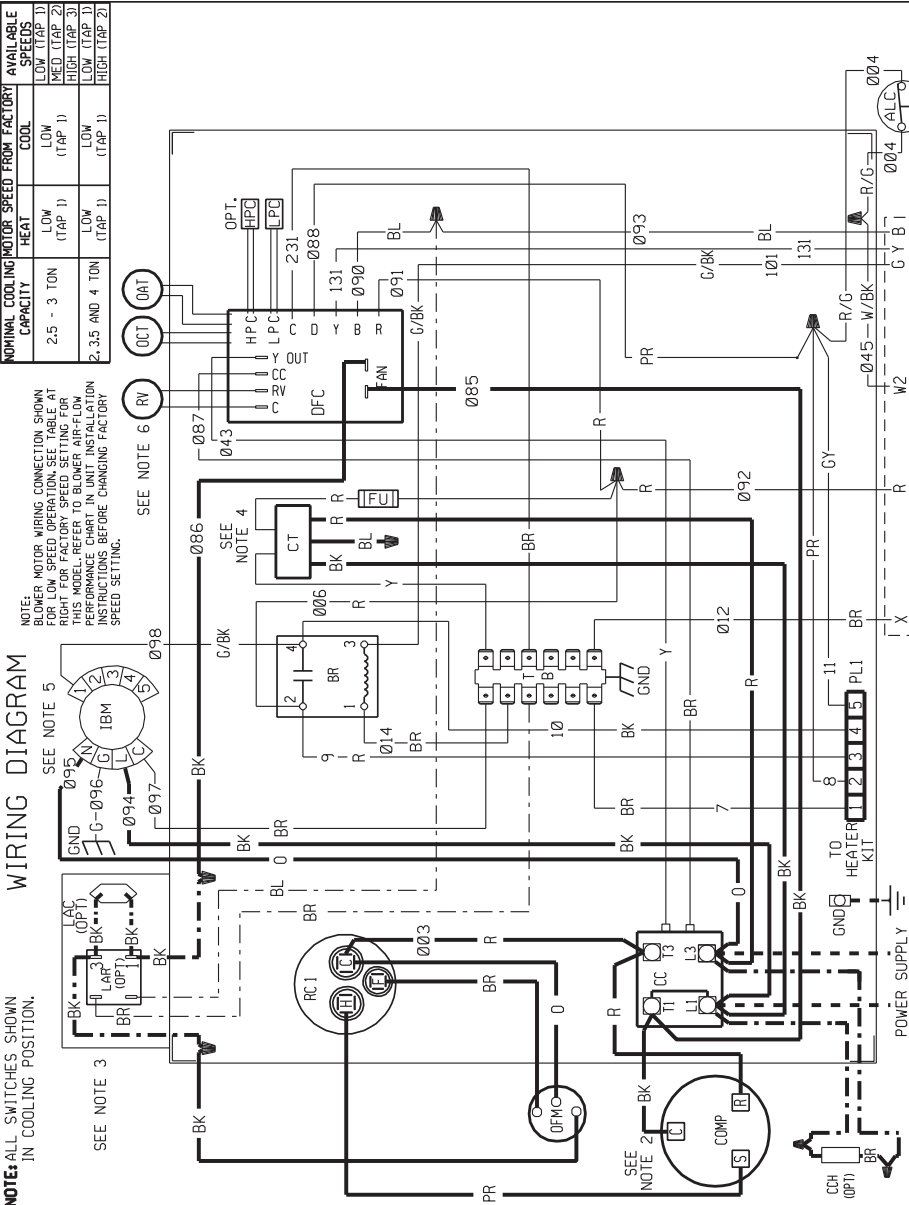
- CONNECTORS SUITABLE FOR USE WITH COPPER CONDUCTORS ONLY.
- COMPRESSOR MOTOR THERMALLY PROTECTED.
- IF LAC/LAR IS NOT USED, CONNECT BLACK WIRE FROM OFM TO WIRE NUT FROM DR.
- TRANSFORMER FACTORY WIRED FOR 230 VOLTS. USE RED AND BLUE LEADS FOR 208 VOLTS.
- MOTOR FACTORY WIRED FOR CORRECT SPEED.
- THIS COMPONENT ENERGIZED IN HEATING.
- SEE FUSE LABEL ON CONTROL BOX COVER FOR FUSE SIZING AND CLASSIFICATION.

**COMPONENT CODE**

LAR	LOW AMBIENT CONTROL
ALC	AUX. LIMIT CONTROL
BR	BLOWER RELAY
CC	COMPRESSOR CONTACTOR
CH (OPT)	CRANKCASE HEATER
CC	COMPRESSOR
COMP	COMPRESSOR
CT	CONTROL TRANSFORMER
DFC	DEFROST CONTROL
FUSE	FUSE
PL	PLUG
RC	RUN CAPACITOR
RV	REVERSING VALVE
GND	GROUND
HPC	HIGH PRESSURE CONTROL
IBM	INDOOR BLOWER MOTOR
LAC	LOW AMBIENT COOLING CONTROL
LPC	LOW PRESSURE CONTROL
OPT	OPTIONAL
PL	PLUG
RC	RUN CAPACITOR
RV	REVERSING VALVE
TB	TERMINAL BLOCK
TO OPT. HEATER KIT	TO OPTIONAL HEATER KIT
WIRE NUT	WIRE NUT

**FIGURE 13**  
**WIRING DIAGRAM**

**SCHEMATIC DIAGRAM**



**NOMINAL COOLING MOTOR SPEED FROM FACTORY**

CAPACITY	HEAT	COOL	AVAILABLE SPEEDS (1)
2.5 - 3 TON	(TAP 1)	(TAP 1)	LOW (TAP 2)
2.5 AND 4 TON	(TAP 1)	(TAP 1)	HIGH (TAP 2)

**NOTE:** BLOWER MOTOR WIRING CONNECTION SHOWN FOR LOW SPEED OPERATION. SEE TABLE AT RIGHT FOR LOW SPEED OPERATION. SEE TABLE AT THIS MODEL REFER TO BLOWER AIR-FLOW INSTRUCTIONS BEFORE CHANGING FACTORY SPEED SETTING.

**WIRING DIAGRAM**



**NOTE:** ALL SWITCHES SHOWN IN COOLING POSITION.

**WIRING INFORMATION**

- LINE VOLTAGE
- FACTORY STANDARD
- FACTORY OPTION
- FIELD INSTALLED
- LOW VOLTAGE
- FACTORY STANDARD
- FIELD INSTALLED
- REPLACEMENT WIRE
- MUST BE THE SAME SIZE AND TYPE OF INSULATION AS ORIGINAL (105 C. MIN.)
- WARNING
- CABINET MUST BE PERMANENTLY GROUNDED AND CONFORM TO I.E.C., N.E.C., C.E.C. NATIONAL WIRING REGULATIONS, AND LOCAL CODES AS APPLICABLE.

**NOTES:**

1. CONNECTORS SUITABLE FOR USE WITH COPPER CONDUCTORS ONLY.
2. COMPRESSOR MOTOR THERMALLY PROTECTED.
3. IF LAC/LAR IS NOT USED, CONNECT BLACK WIRE FROM OFM TO WIRE NUT FROM DR
4. TRANSFORMER FACTORY WIRE FOR 230 VOLTS. USE RED AND BLUE LEADS FOR 208 VOLTS.
5. MOTOR FACTORY WIRED FOR CORRECT SPEED.
6. THIS COMPONENT WIRED FOR HEATING.
7. SEE FUSE LABEL ON CONTROL BOX COVER FOR FUSE SIZING AND CLASSIFICATION.

**COMPONENT CODE**

- ALC AUX. LIMIT CONTROL
- BR BLOWER RELAY CONTACTOR
- CC COMPRESSOR CAPACITOR
- CH (OPT) HEATER
- COMP COMPRESSOR
- CT CONTROL TRANSFORMER
- DEFROST CONTROL
- FUSE FUSE
- GROUND HIGH PRESSURE CONTROL
- HFC INDOOR BLOWER MOTOR
- IBM LOW AMBIENT COOLING CONTROL
- LAR LOW AMBIENT RELAY
- LPC LOW PRESSURE CONTROL
- OAT OUTDOOR AMBIENT TEMP
- RC REVERSING VALVE
- RC RUN CAPACITOR
- RC REVERSING VALVE
- RB TERMINAL BLOCK
- WIRE NUT

**WIRE COLOR CODE**

- BK BLACK
- BR BROWN
- BL BLUE
- G GREEN
- GY GRAY
- OR ORANGE
- PR PURPLE
- RED RED
- W WHITE
- Y YELLOW

**ELECTRICAL WIRING DIAGRAM**

**PACKAGE HEAT PUMP**  
1 PH, 208-230 VOLT  
X-13 INDOOR BLOWER MOTOR

REV	DATE	APP. BY	DWG. NO.
03	6-18-10	MGR	90-23621-32

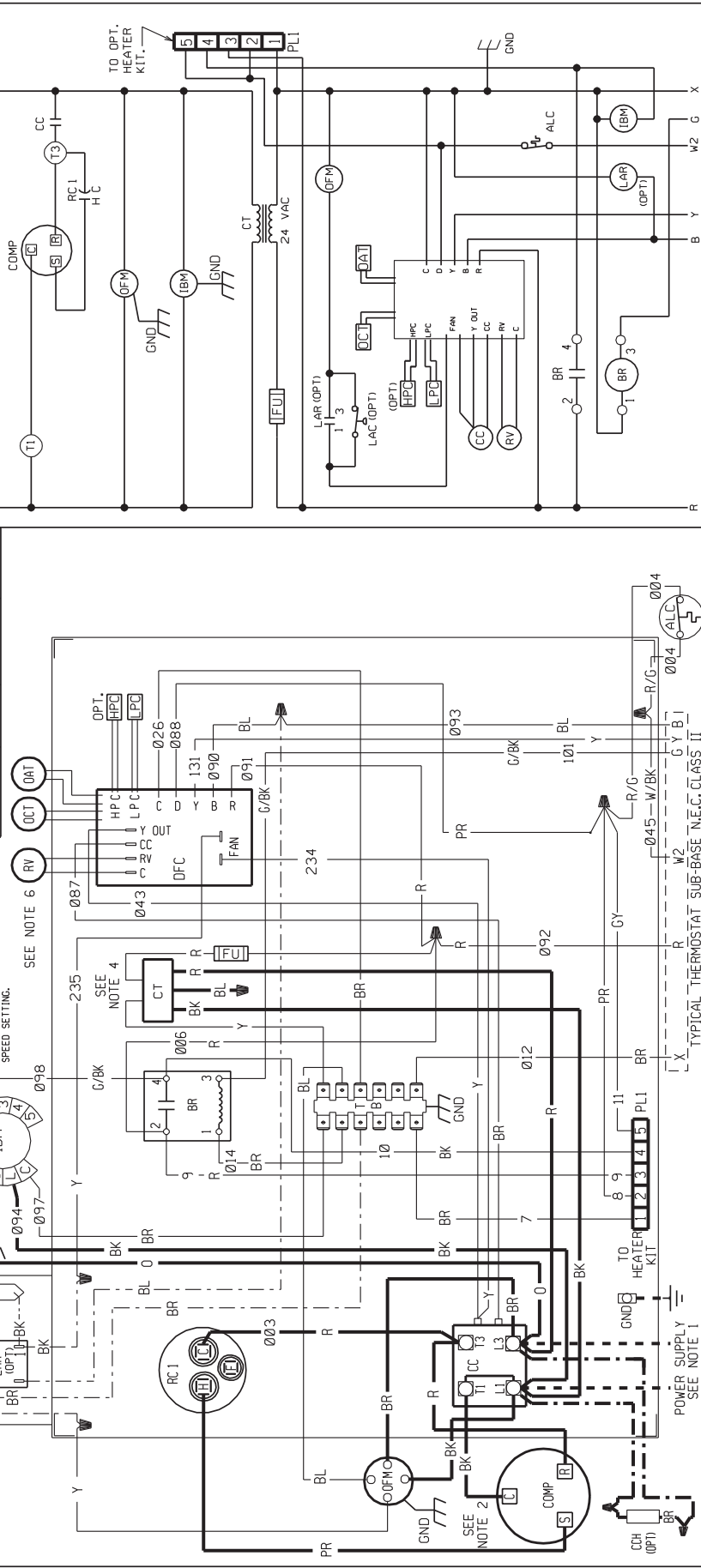
**FIGURE 14**  
**WIRING DIAGRAM**

**SCHEMATIC DIAGRAM**

NOMINAL COOLING MOTOR SPEED FROM FACTORY		AVAILABLE SPEEDS	
CAPACITY	HEAT	LOW (TAP 1)	HIGH (TAP 2)
2.5 - 3 TON	LOW (TAP 1)	LOW (TAP 2)	HIGH (TAP 2)
2.35 AND 4 TON	LOW (TAP 1)	LOW (TAP 2)	HIGH (TAP 2)

**NOTE:** BLOWER MOTOR WIRING CONNECTION SHOWN FOR LOW SPEED OPERATION. SEE TABLE AT RIGHT FOR LOW SPEED SETTING. SEE TABLE AT THIS MODEL. REFER TO BLOWER AIR-FLOW INSTRUCTIONS BEFORE CHANGING FACTORY SPEED SETTING.

**NOTE:** ALL SWITCHES SHOWN IN COOLING POSITION.



SEE NOTE 3  
SEE NOTE 4  
SEE NOTE 5  
SEE NOTE 6

**WIRE COLOR CODE**

BK	BLACK	G	GREEN	PR	PURPLE
BR	BROWN	GY	GRAY	R	RED
BL	BLUE	O	ORANGE	W	WHITE
CL	CLEAR	PK	PINK	Y	YELLOW

**WIRING INFORMATION**

- LINE VOLTAGE
- FACTORY STANDARD
- FACTORY OPTION
- FIELD INSTALLED
- LOW VOLTAGE
- FACTORY STANDARD
- FACTORY OPTION
- FIELD INSTALLED
- REPLACEMENT WIRE
- MUST BE THE SAME SIZE AND TYPE OF INSULATION AS ORIGINAL (105 C MIN.)
- WARNING
- CABINET MUST BE PERMANENTLY GROUNDED AND CONFORM TO I.E.C., N.E.C., C.E.C. AND LOCAL CODES AS APPLICABLE.

**NOTES:**

- CONNECTORS SUITABLE FOR USE WITH COPPER CONDUCTORS ONLY.
- COMPRESSOR MOTOR THERMALLY PROTECTED. IF LAC/LAR IS NOT USED, CONNECT BLACK WIRE FROM COMP TO WIRE NUT FROM DR
- TRANSFORMER FACTORY WIRED FOR 230 VOLTS; USE RED AND BLUE LEADS FOR 208 VOLTS.
- MOTOR FACTORY WIRED FOR CORRECT SPEED. THIS COMPONENT ENERGIZED IN HEATING. SEE FUSE LABEL ON CONTROL BOX COVER FOR FUSE SIZING AND CLASSIFICATION.

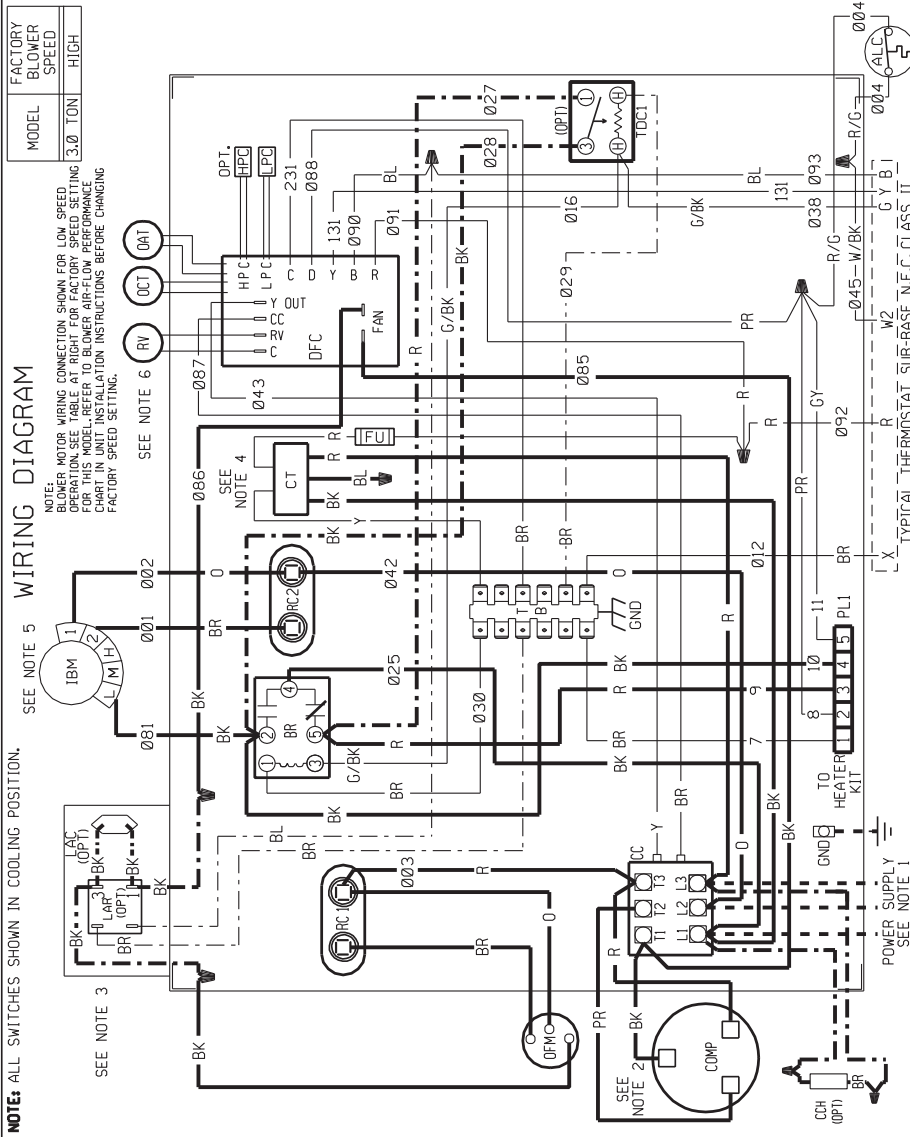
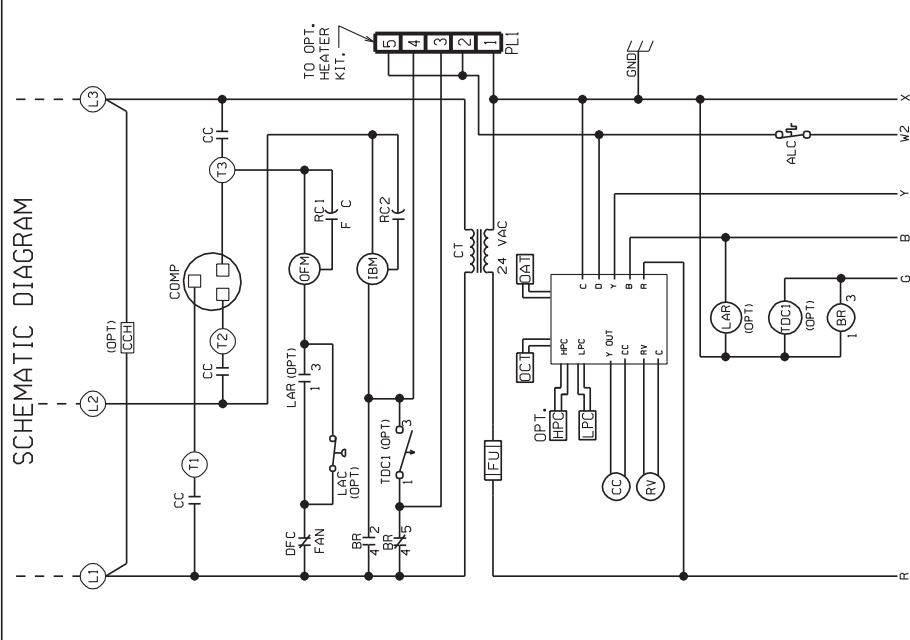
**COMPONENT CODE**

ALC	AUX. LIMIT CONTROL
BR	BLOWER RELAY CONTACTOR
CC	CRANKCASE HEATER
CH	COMPRESSOR HEATER
COMP	CONTROL TRANSFORMER
CT	DEFROST CONTROL
DFC	FUSE
FU	GROUND
GND	HIGH PRESSURE CONTROL
HPC	INDOOR BLOWER MOTOR
IBM	INDOOR BLOWER MOTOR CONTROL
LAC	LOW AMBIENT COOLING CONTROL
LAR	LOW AMBIENT RELAY
LPC	LOW PRESSURE CONTROL
OAT	OUTDOOR AMBIENT TEMP
OC	OUTDOOR FAN CONTROL
OCF	OUTDOOR FAN CONTROL OPTIONAL
OPT	OPTIONAL
PL	PLUG
RC	RUN CAPACITOR
RV	REVERSING VALVE
TB	TERMINAL BLOCK
W	WIRE NUT

**ELECTRICAL WIRING DIAGRAM**  
**PACKAGE HEAT PUMP**  
ECM OUTDOOR MOTOR  
1 PH, 208-230 VOLT  
INDOOR BLOWER MOTOR

DR. BY	APP. BY	DATE	DWG. NO.	REV
	X-13	7-19-10	90-23621-37	01

**FIGURE 15**  
**WIRING DIAGRAM**



MODEL	FACTORY BLOWER SPEED
3.0 TON	HIGH

**NOTE:** BLOWER MOTOR WIRING CONNECTION SHOWN FOR LOW SPEED OPERATION. SEE TABLE AT RIGHT FOR FACTORY SPEED SETTING FOR THIS MODEL. REFER TO BLOWER AIR-FLOW PERFORMANCE CHART ON UNIT INSTALLATION INSTRUCTIONS BEFORE CHANGING FACTORY SPEED SETTING.

SEE NOTE 6

**NOTE:** ALL SWITCHES SHOWN IN COOLING POSITION.

SEE NOTE 5

**SCHEMATIC DIAGRAM**

**WIRE COLOR CODE**

BK	BLACK	O	ORANGE
BR	BROWN	PR	PURPLE
BL	BLUE	R	RED
G	GREEN	W	WHITE
GY	GRAY	Y	YELLOW

**ELECTRICAL WIRING DIAGRAM**

**PACKAGE HEAT PUMP**

3 PH, 208-230 VOLT

PSC INDOOR BLOWER MOTOR

DR. BY MGR    APP. BY DATE    DWG. NO. 90-23621-33    REV 03

**WIRING INFORMATION**

LINE VOLTAGE  
 -FACTORY STANDARD  
 -FACTORY OPTION  
 -FIELD INSTALLED  
 LOW VOLTAGE  
 -FACTORY STANDARD  
 -FACTORY OPTION  
 -FIELD INSTALLED  
 -REPLACEMENT WIRE  
 -MUST BE THE SAME SIZE AND TYPE OF INSULATION AS ORIGINAL (105 C. MIN.)

**NOTES:**

- CONNECTORS SUITABLE FOR USE WITH COPPER CONDUCTORS ONLY.
- COMPRESSOR MOTOR THERMALLY PROTECTED.
- IF LAC/LAR IS NOT USED, CONNECT BLACK WIRE FROM OPT. TO WIRE NUT FROM DR.
- TRANSFORMER FACTORY WIRED FOR 230 VOLTS. USE RED AND BLUE LEADS FOR 208 VOLTS.
- MOTOR FACTORY WIRED FOR CORRECT SPEED.
- THIS COMPONENT ENERGIZED IN HEATING.
- SEE FUSE LABEL ON CONTROL BOX COVER FOR FUSE SIZING AND CLASSIFICATION.

X TYPICAL THERMOSTAT SUB-BASE N.E.C. CLASS II

**COMPONENT CODE**

ALC	AUX. LIMIT CONTROL
BR	BLOWER RELAY
CC	COMPRESSOR CONTACTOR
CCH	CRANKCASE HEATER
COMP	COMPRESSOR
CT	CONTROL TRANSFORMER
FUSE	FUSE
FLC	FAN MOTOR CONTROL
GND	GROUND
HPC	HIGH PRESSURE CONTROL
IBM	INDOOR BLOWER MOTOR
LAC	LOW AMBIENT COOLING CONTROL
LAR	LOW AMBIENT RELAY
LPC	LOW PRESSURE CONTROL
OAT	OUTDOOR AMBIENT TEMP
OCCT	OUTDOOR COIL TEMP
OFM	OUTDOOR FAN MOTOR
OPT	OPTIONAL PLUG
PC	RUN CAPACITOR
RV	REVERSING VALVE
TB	TERMINAL BLOCK
TDC	TIME DELAY CONTROL
WIRE NUT	WIRE NUT

**NOTES:**

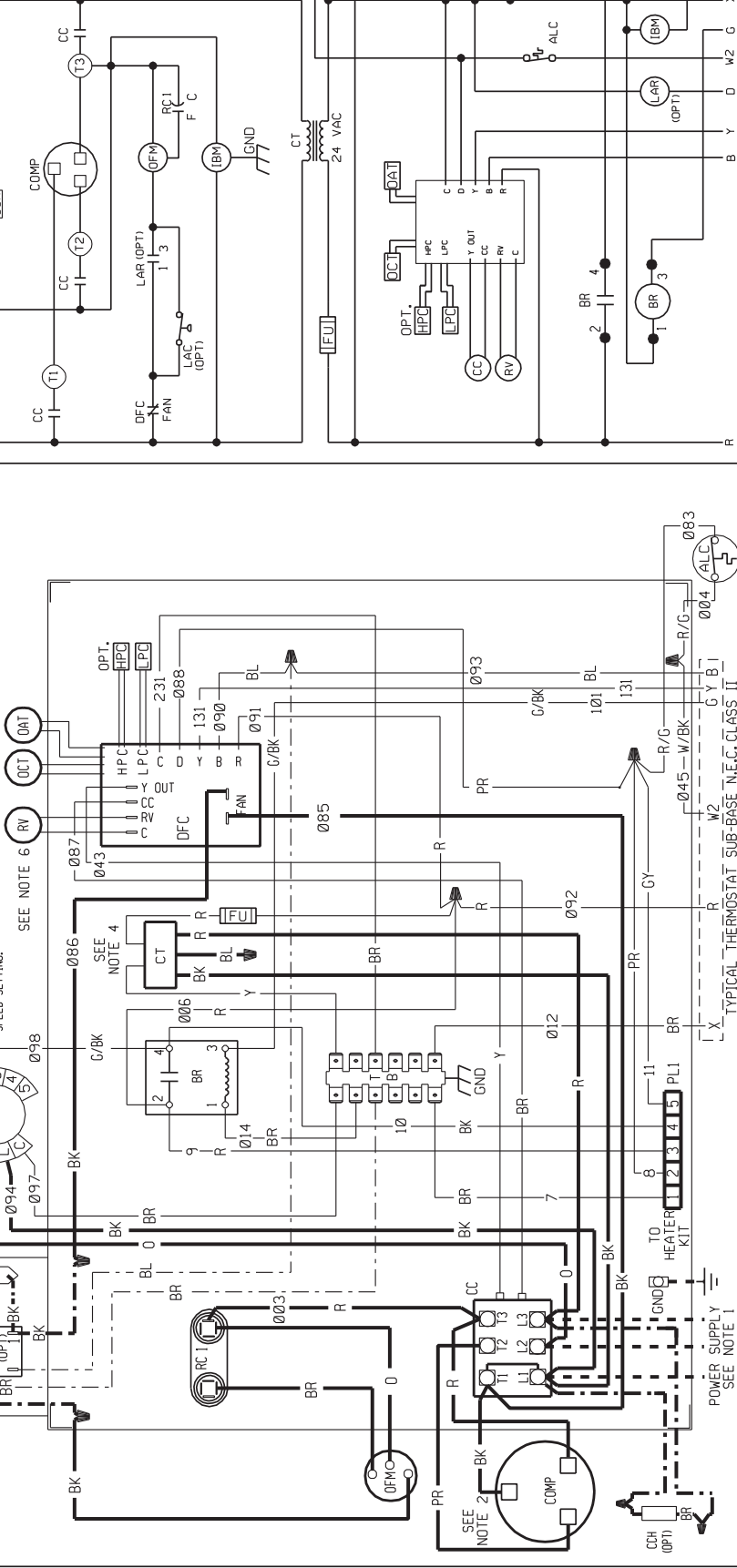
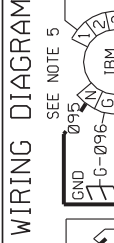
- CONNECTORS SUITABLE FOR USE WITH COPPER CONDUCTORS ONLY.
- COMPRESSOR MOTOR THERMALLY PROTECTED.
- IF LAC/LAR IS NOT USED, CONNECT BLACK WIRE FROM OPT. TO WIRE NUT FROM DR.
- TRANSFORMER FACTORY WIRED FOR 230 VOLTS. USE RED AND BLUE LEADS FOR 208 VOLTS.
- MOTOR FACTORY WIRED FOR CORRECT SPEED.
- THIS COMPONENT ENERGIZED IN HEATING.
- SEE FUSE LABEL ON CONTROL BOX COVER FOR FUSE SIZING AND CLASSIFICATION.

**FIGURE 16**  
**WIRING DIAGRAM**

**SCHEMATIC DIAGRAM**

NOMINAL COOLING MOTOR SPEED FROM FACTORY		AVAILABLE SPEEDS	
CAPACITY	HEAT	LOW (TAP 1)	HIGH (TAP 2)
2.5 - 3 TON	LOW (TAP 1)	LOW (TAP 1)	HIGH (TAP 2)
2.35 AND 4 TON	LOW (TAP 1)	LOW (TAP 1)	HIGH (TAP 2)

**NOTE:** BLOWER MOTOR WIRING CONNECTION SHOWN FOR LOW SPEED OPERATION. SEE TABLE AT RIGHT FOR SPEED SETTING. THIS MODEL REFERS TO BLOWER AIR-FLOW INSTRUCTIONS BEFORE CHANGING FACTORY SPEED SETTING.



**WIRING INFORMATION**

- LINE VOLTAGE
- FACTORY STANDARD
- FACTORY OPTION
- FIELD INSTALLED
- LOW VOLTAGE
- FACTORY STANDARD
- FACTORY OPTION
- FIELD INSTALLED
- REPLACEMENT WIRE
- MUST BE THE SAME SIZE AND TYPE OF INSULATION AS ORIGINAL (105 C. MIN.)
- WARNING
- CABINET MUST BE PERMANENTLY GROUNDED AND CONFORM TO I.E.C., N.E.C., C.E.C. NATIONAL WIRING REGULATIONS, AND LOCAL CODES AS APPLICABLE.

**NOTES:**

- CONNECTORS SUITABLE FOR USE WITH COPPER CONDUCTORS ONLY.
- COMPRESSOR MOTOR THERMALLY PROTECTED.
- IF LAC/LAR IS NOT USED, CONNECT BLACK WIRE FROM OFM TO WIRE NUT FROM DR
- TRANSFORMER FACTORY WIRED FOR 230 VOLTS. USE RED AND BLUE LEADS FOR 208 VOLTS.
- MOTOR FACTORY WIRED FOR CORRECT SPEED.
- THIS COMPONENT ENERGIZED IN HEATING.
- SEE FUSE LABEL ON CONTROL BOX COVER FOR FUSE SIZING AND CLASSIFICATION.

**COMPONENT CODE**

- ALC AUX. LIMIT CONTROL
- BR BLOWER RELAY CONTACTOR
- CC CAPACITOR
- CH (OPT) HEATER
- COMP COMPRESSOR
- CT CONTROL TRANSFORMER
- DFC DEFROST CONTROL
- FU FUSE
- GND GROUND
- HPC HIGH PRESSURE CONTROL
- IBM INDOOR BLOWER MOTOR
- LAC LOW AMBIENT COOLING CONTROL
- LAR LOW AMBIENT RELAY
- LPC LOW PRESSURE CONTROL
- OAT OUTDOOR AMBIENT TEMP CONTROL
- OFM OUTDOOR FAN MOTOR
- OPT OPTIONAL
- PL PLUG
- RC RUN CAPACITOR
- RV REVERSING VALVE
- TB TERMINAL BLOCK
- WIRE NUT

**WIRE COLOR CODE**

- BK BLACK
- BR BROWN
- BL BLUE
- G GREEN
- GY GRAY
- O ORANGE
- PR PURPLE
- R RED
- W WHITE
- Y YELLOW

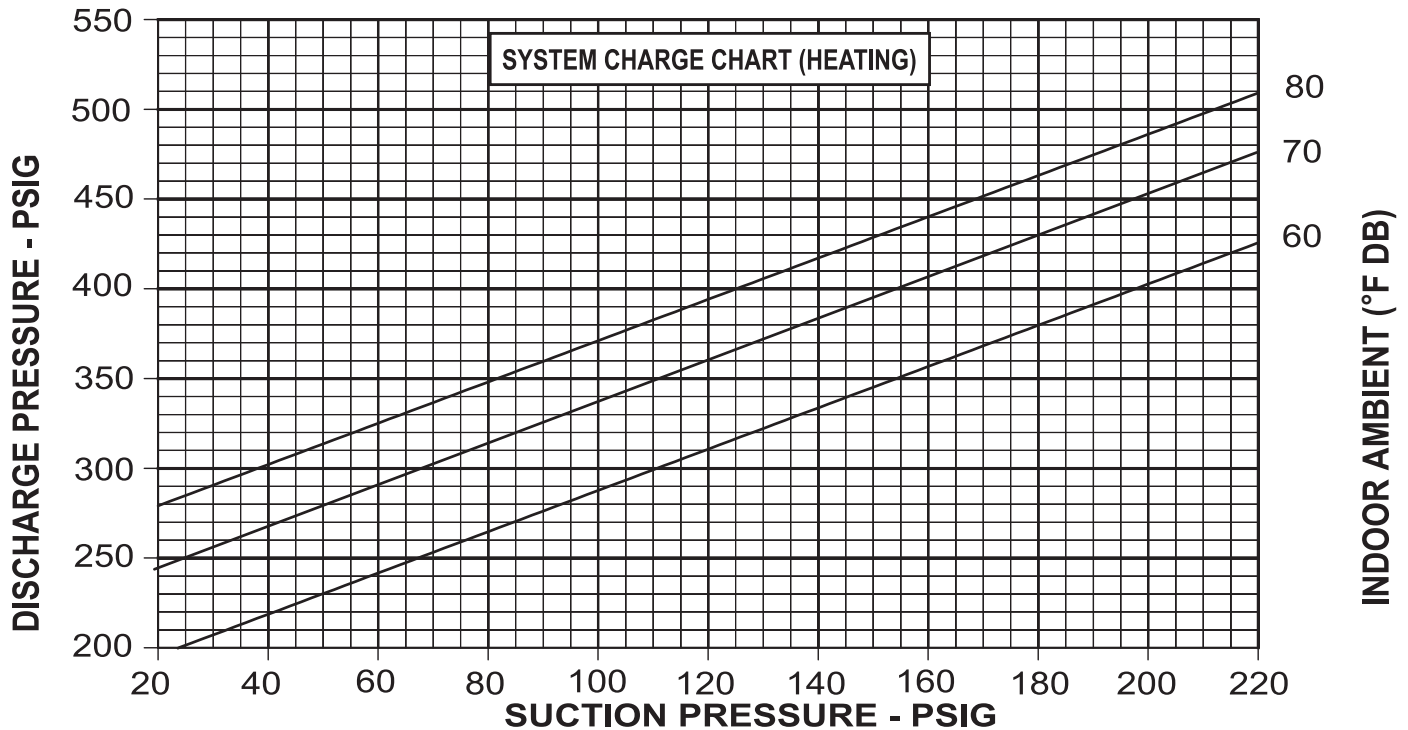
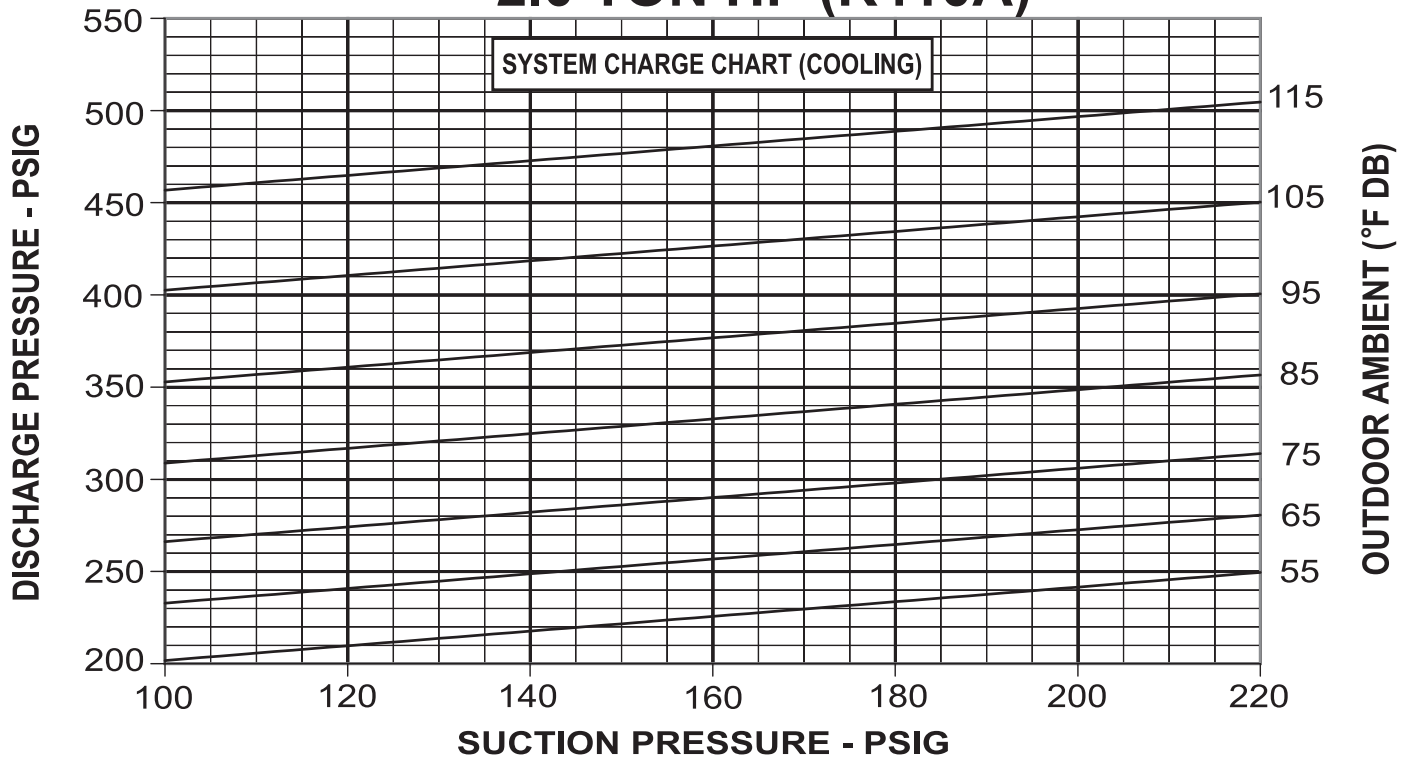
**ELECTRICAL WIRING DIAGRAM**

**PACKAGE HEAT PUMP**  
3 PH, 208-230 VOLT  
X-13 INDOOR BLOWER MOTOR

DR. BY	APP. BY	DATE	DWG. NO.	REV
MGR		6-18-10	90-23621-34	03

# 2 TON HEAT PUMP

## 2.0 TON HP (R410A)



**CAUTION:** BEFORE FINAL REFRIGERANT CHECK, INDOOR RETURN AIR TEMPERATURE MUST BE BETWEEN 72°F & 76°F DB AT 50% R.H. (COOLING), AND NO ICE ON OUTDOOR COILS (HEATING).

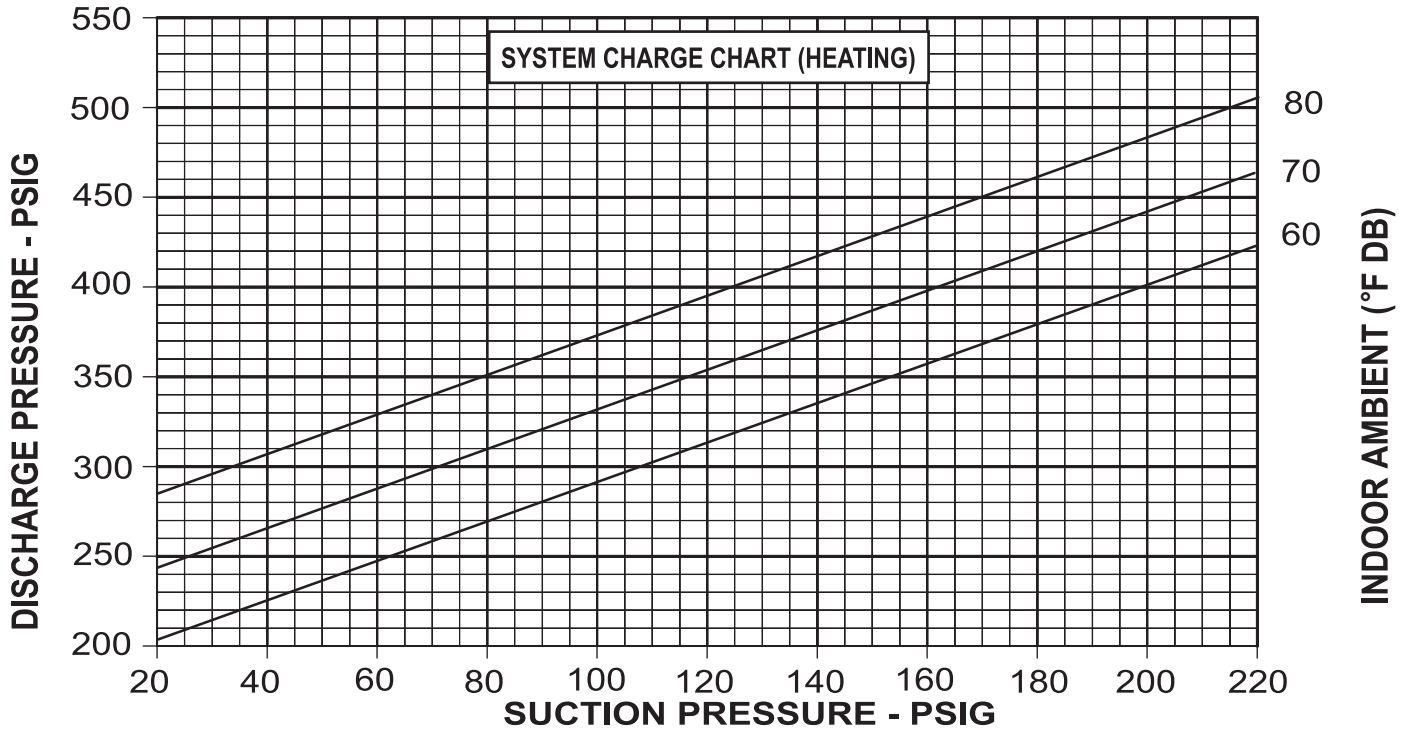
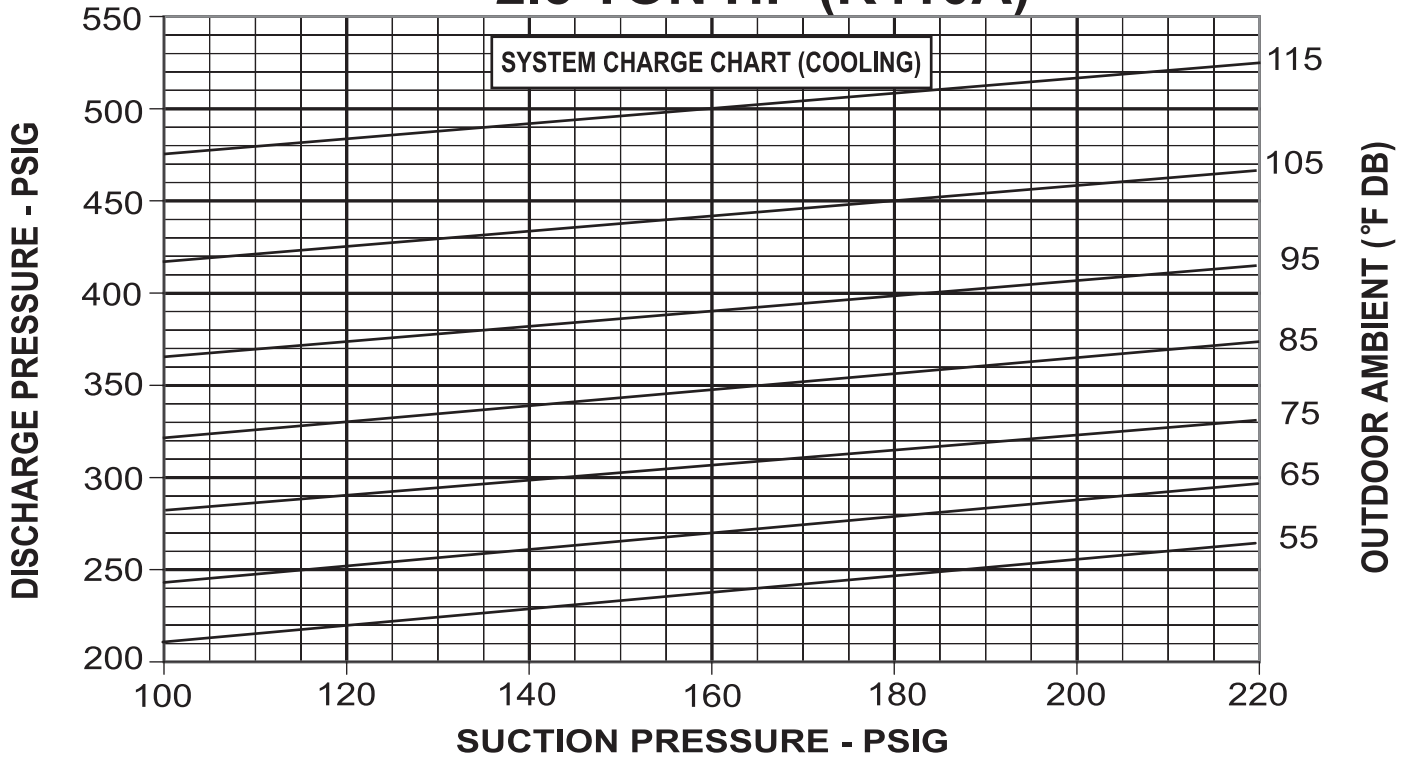
**INSTRUCTIONS:**

1. CONNECT PRESSURE GAUGES TO SUCTION AND DISCHARGE PORTS ON UNIT.
2. MEASURE AIR TEMPERATURE TO: (a) OUTDOOR COIL FOR COOLING, (b) INDOOR COIL FOR HEATING.
3. PLACE AN "X" ON THE APPROPRIATE CHART WHERE THE SUCTION AND DISCHARGE PRESSURES CROSS.
4. IF "X" IS BELOW AMBIENT TEMPERATURE LINE, ADD CHARGE AND REPEAT STEP 3.
5. IF "X" IS ABOVE AMBIENT TEMPERATURE LINE, RECOVER EXCESS CHARGE AND REPEAT STEP 3.

92-102223-01-02

# 2.5 TON HEAT PUMP

## 2.5 TON HP (R410A)



**CAUTION:** BEFORE FINAL REFRIGERANT CHECK, INDOOR RETURN AIR TEMPERATURE MUST BE BETWEEN 72°F & 76°F DB AT 50% R.H. (COOLING), AND NO ICE ON OUTDOOR COILS (HEATING).

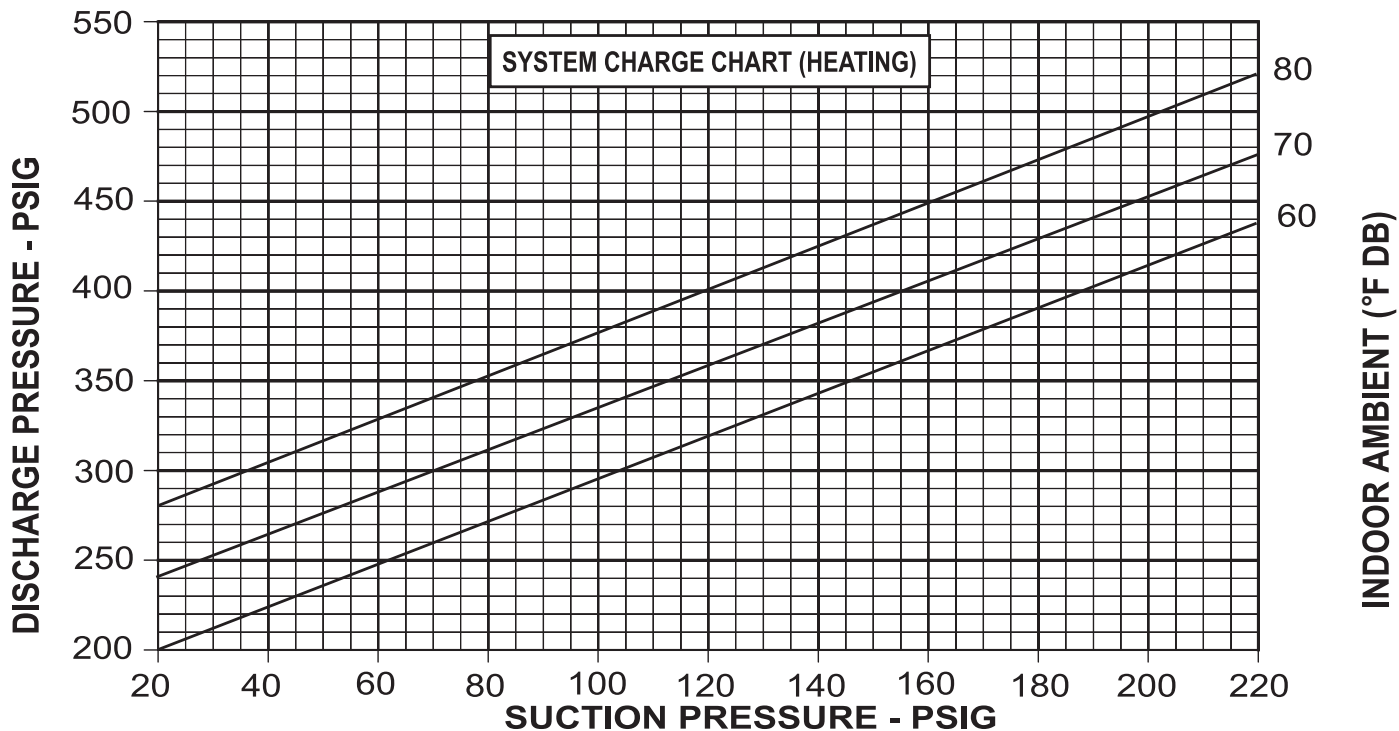
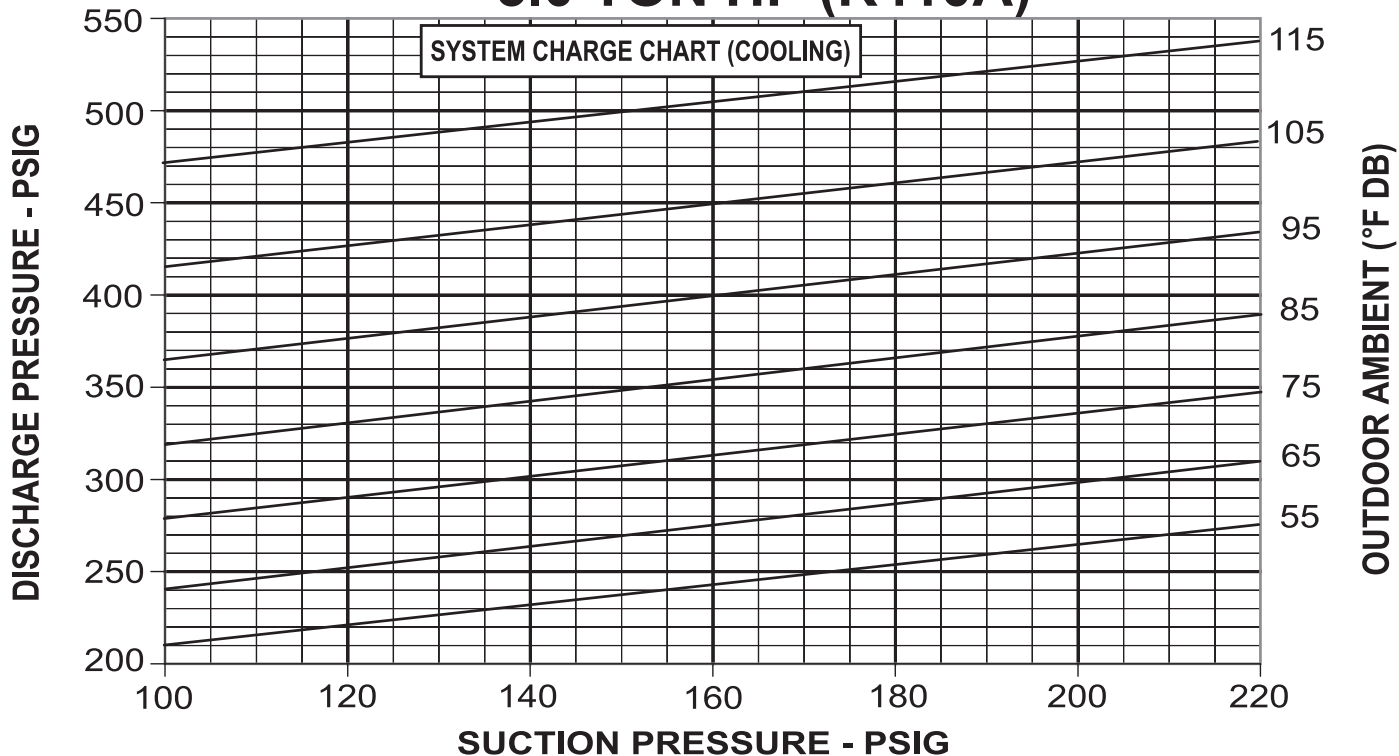
**INSTRUCTIONS:**

1. CONNECT PRESSURE GAUGES TO SUCTION AND DISCHARGE PORTS ON UNIT.
2. MEASURE AIR TEMPERATURE TO: (a) OUTDOOR COIL FOR COOLING, (b) INDOOR COIL FOR HEATING.
3. PLACE AN "X" ON THE APPROPRIATE CHART WHERE THE SUCTION AND DISCHARGE PRESSURES CROSS.
4. IF "X" IS BELOW AMBIENT TEMPERATURE LINE, ADD CHARGE AND REPEAT STEP 3.
5. IF "X" IS ABOVE AMBIENT TEMPERATURE LINE, RECOVER EXCESS CHARGE AND REPEAT STEP 3.

92-102223-02-02

# 3.0 TON HEAT PUMP

## 3.0 TON HP (R410A)



**CAUTION:** BEFORE FINAL REFRIGERANT CHECK, INDOOR RETURN AIR TEMPERATURE MUST BE BETWEEN 72°F & 76°F DB AT 50% R.H. (COOLING), AND NO ICE ON OUTDOOR COILS (HEATING).

**INSTRUCTIONS:**

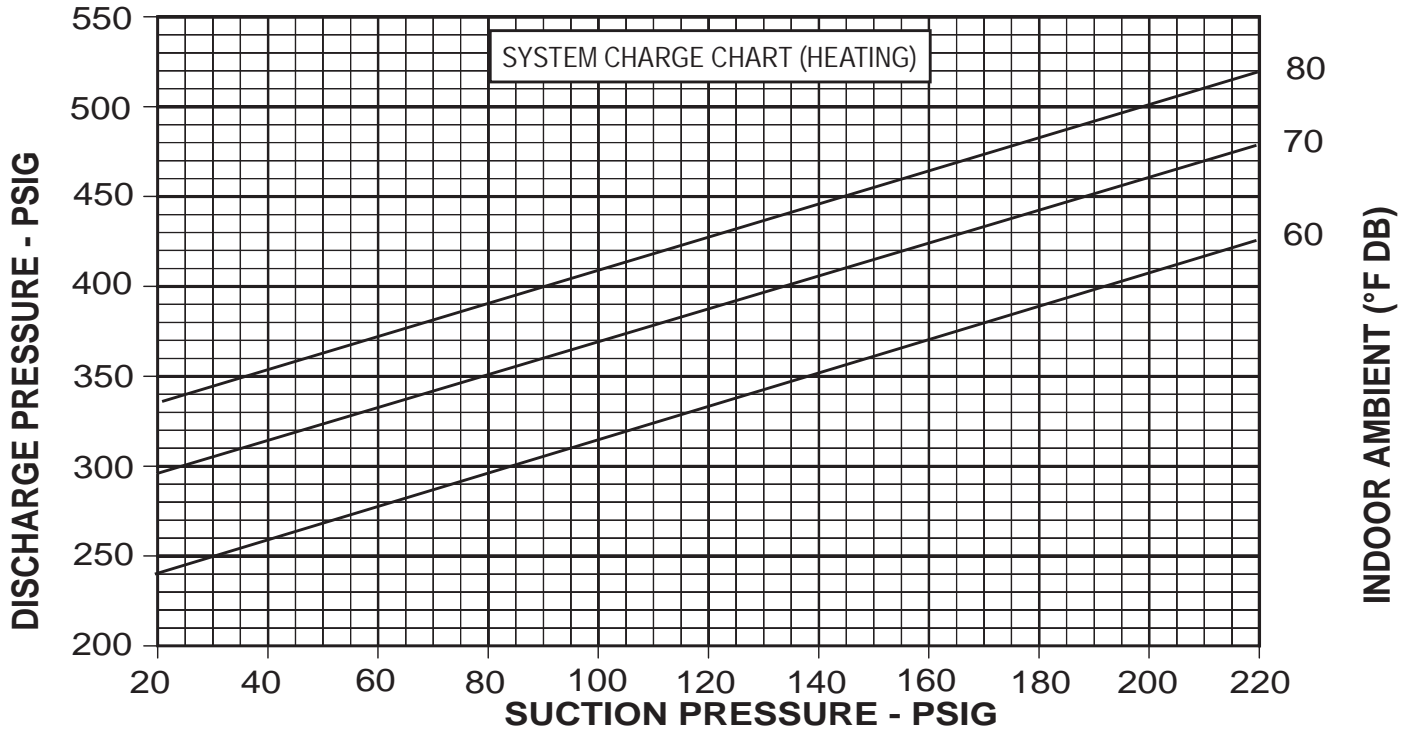
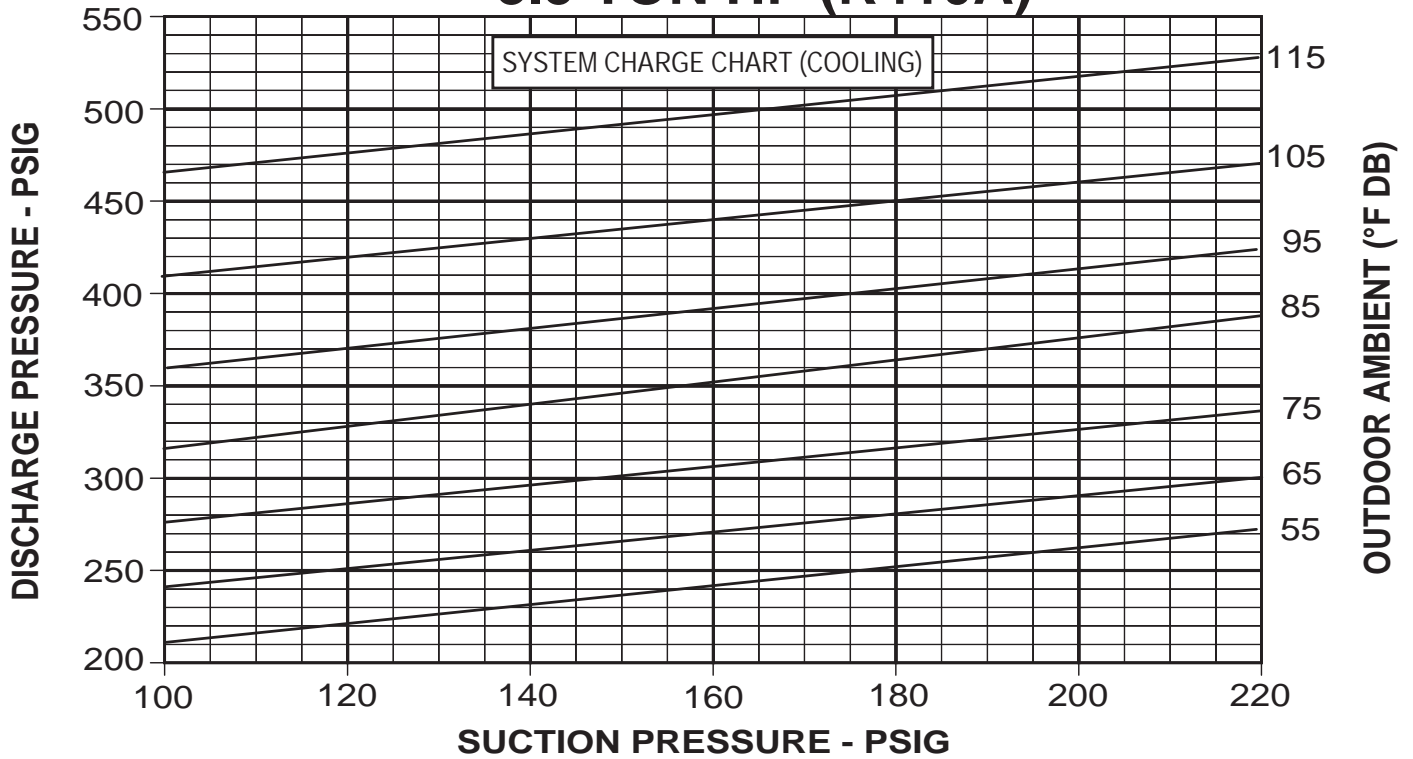
1. CONNECT PRESSURE GAUGES TO SUCTION AND DISCHARGE PORTS ON UNIT.
2. MEASURE AIR TEMPERATURE TO: (a) OUTDOOR COIL FOR COOLING, (b) INDOOR COIL FOR HEATING.
3. PLACE AN "X" ON THE APPROPRIATE CHART WHERE THE SUCTION AND DISCHARGE PRESSURES CROSS.
4. IF "X" IS BELOW AMBIENT TEMPERATURE LINE, ADD CHARGE AND REPEAT STEP 3.
5. IF "X" IS ABOVE AMBIENT TEMPERATURE LINE, RECOVER EXCESS CHARGE AND REPEAT STEP 3.

92-102223-03-02



# 3.5 TON HEAT PUMP

## 3.5 TON HP (R410A)



**CAUTION:** BEFORE FINAL REFRIGERANT CHECK, INDOOR RETURN AIR TEMPERATURE MUST BE BETWEEN 72°F & 76°F DB AT 50% R.H. (COOLING), AND NO ICE ON OUTDOOR COILS (HEATING).

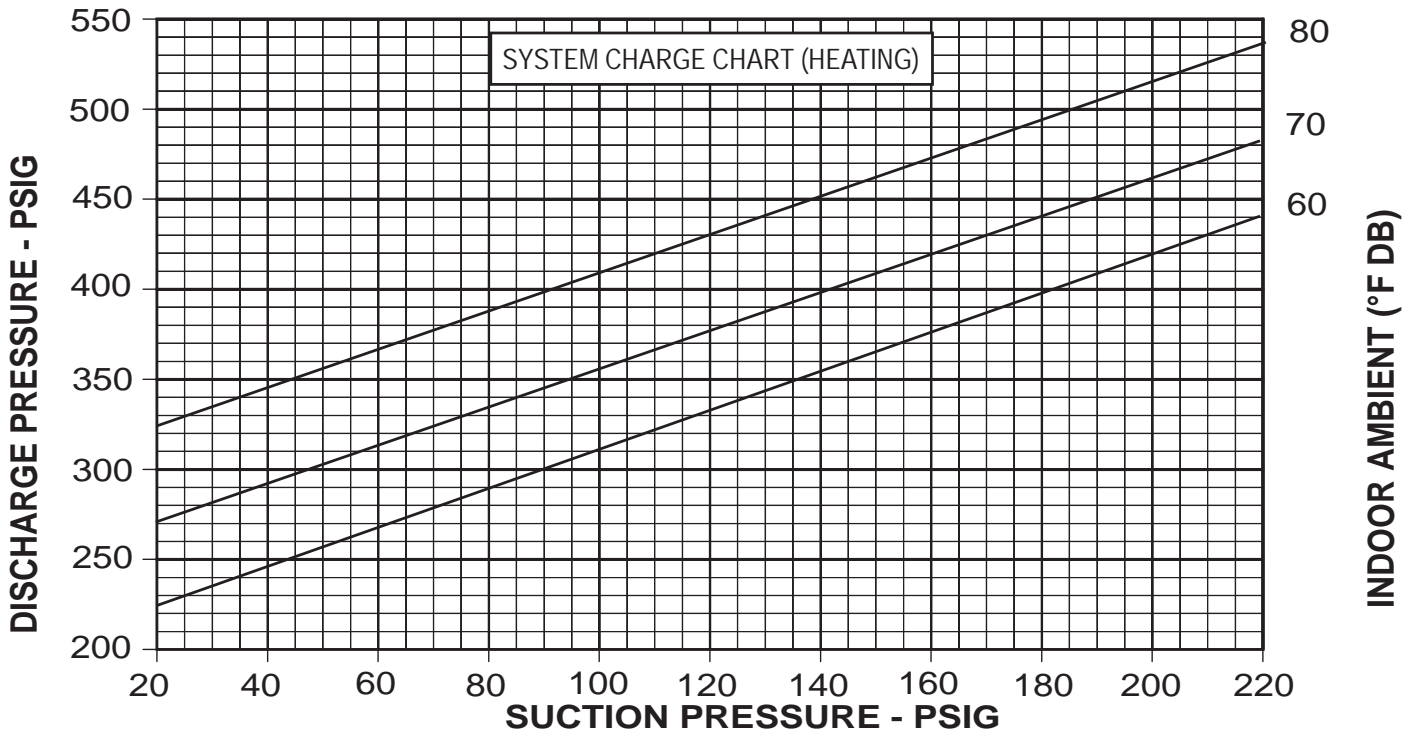
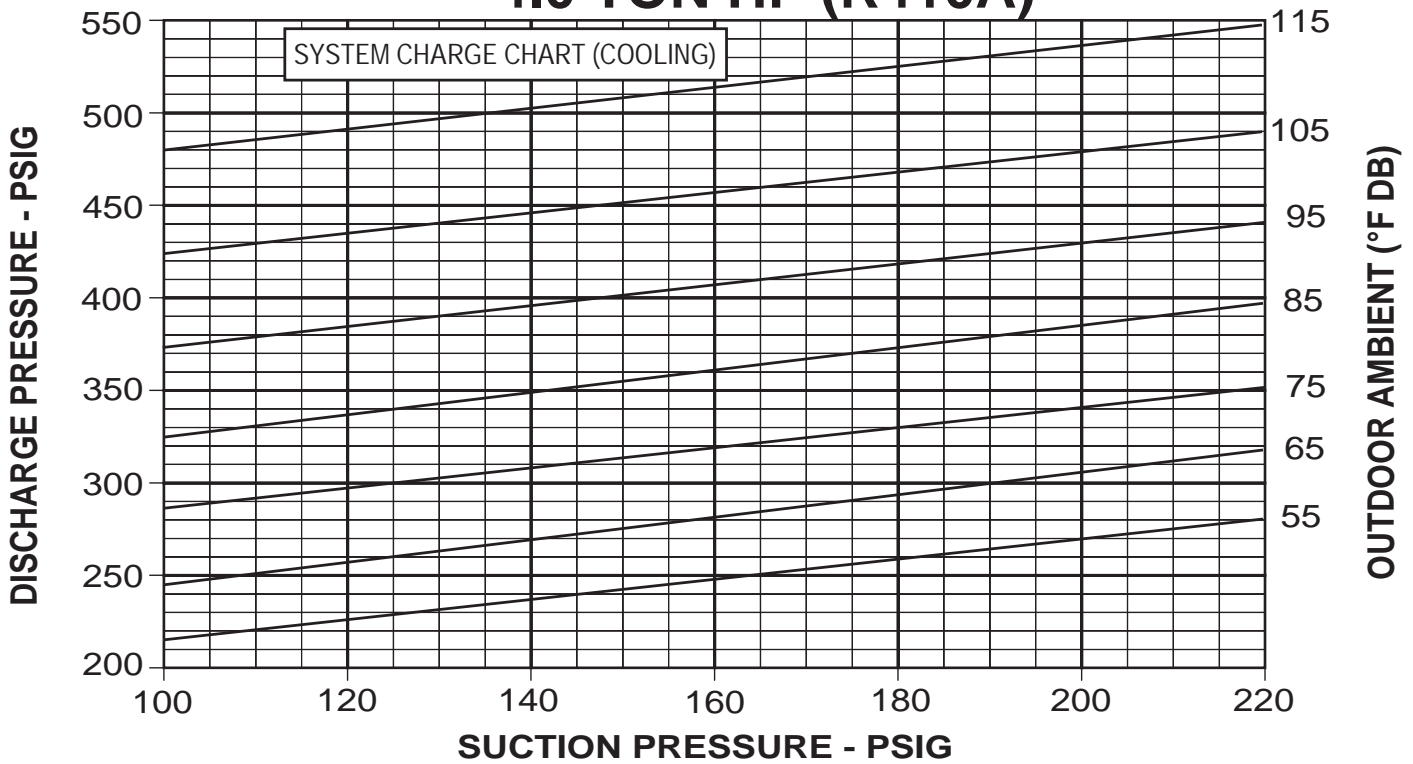
**INSTRUCTIONS:**

1. CONNECT PRESSURE GAUGES TO SUCTION AND DISCHARGE PORTS ON UNIT.
2. MEASURE AIR TEMPERATURE TO: (a) OUTDOOR COIL FOR COOLING, (b) INDOOR COIL FOR HEATING.
3. PLACE AN "X" ON THE APPROPRIATE CHART WHERE THE SUCTION AND DISCHARGE PRESSURES CROSS.
4. IF "X" IS BELOW AMBIENT TEMPERATURE LINE, ADD CHARGE AND REPEAT STEP 3.
5. IF "X" IS ABOVE AMBIENT TEMPERATURE LINE, RECOVER EXCESS CHARGE AND REPEAT STEP 3.

92-102223-04-02

# 4.0 TON HEAT PUMP

## 4.0 TON HP (R410A)



**CAUTION:** BEFORE FINAL REFRIGERANT CHECK, INDOOR RETURN AIR TEMPERATURE MUST BE BETWEEN 72°F & 76°F DB AT 50% R.H. (COOLING), AND NO ICE ON OUTDOOR COILS (HEATING).

**INSTRUCTIONS:**

1. CONNECT PRESSURE GAUGES TO SUCTION AND DISCHARGE PORTS ON UNIT.
2. MEASURE AIR TEMPERATURE TO: (a) OUTDOOR COIL FOR COOLING, (b) INDOOR COIL FOR HEATING.
3. PLACE AN "X" ON THE APPROPRIATE CHART WHERE THE SUCTION AND DISCHARGE PRESSURES CROSS.
4. IF "X" IS BELOW AMBIENT TEMPERATURE LINE, ADD CHARGE AND REPEAT STEP 3.
5. IF "X" IS ABOVE AMBIENT TEMPERATURE LINE, RECOVER EXCESS CHARGE AND REPEAT STEP 3.

92-102223-05-02

# TROUBLE SHOOTING CHART

**▲ WARNING**

**DISCONNECT ALL POWER TO UNIT BEFORE SERVICING. CONTACTOR MAY BREAK ONLY ONE SIDE. FAILURE TO SHUT OFF POWER CAN CAUSE ELECTRICAL SHOCK RESULTING IN PERSONAL INJURY OR DEATH.**

SYMPTOM	POSSIBLE CAUSE	REMEDY
Unit will not run	<ul style="list-style-type: none"> <li>• Power off or loose electrical connection</li> <li>• Thermostat out of calibration-set too high</li> <li>• Defective contactor</li> <li>• Blown fuses</li> <li>• Transformer defective</li> <li>• High pressure control open (if provided)</li> <li>• Interconnecting low voltage wiring damaged</li> </ul>	<ul style="list-style-type: none"> <li>• Check for correct voltage at compressor contactor in control box</li> <li>• Reset</li> <li>• Check for 24 volts at contactor coil - replace if contacts are open</li> <li>• Replace fuses</li> <li>• Check wiring-replace transformer</li> <li>• Reset-also see high head pressure remedy-</li> <li>• Replace thermostat wiring</li> </ul>
Condenser fan runs, compressor doesn't	<ul style="list-style-type: none"> <li>• Run capacitor defective (single phase only)</li> <li>• Loose connection</li> <li>• Compressor stuck, grounded or open motor winding, open internal overload.</li> <li>• Low voltage condition</li> <li>• Low voltage condition</li> </ul>	<ul style="list-style-type: none"> <li>• Replace</li> <li>• Check for correct voltage at compressor - check &amp; tighten all connections</li> <li>• Wait at least 2 hours for overload to reset. If still open, replace the compressor.</li> <li>• At compressor terminals, voltage must be within 10% of rating</li> <li>• Add start kit components</li> </ul>
Insufficient cooling	<ul style="list-style-type: none"> <li>• Improperly sized unit</li> <li>• Improper airflow</li> <li>• Incorrect refrigerant charge</li> <li>• Air, non-condensibles or moisture in system</li> <li>• Incorrect voltage</li> </ul>	<ul style="list-style-type: none"> <li>• Recalculate load</li> <li>• Check - should be approximately 400 CFM per ton.</li> <li>• Charge per procedure attached to unit service panel</li> <li>• Recover refrigerant, evacuate &amp; recharge, add filter drier</li> <li>• At compressor terminals, voltage must be within 10% of rating plate volts when unit is operating.</li> </ul>
Compressor short cycles	<ul style="list-style-type: none"> <li>• Incorrect voltage</li> <li>• Defective overload protector</li> <li>• Refrigerant undercharge</li> </ul>	<ul style="list-style-type: none"> <li>• At compressor terminals, voltage must be <math>\pm 10\%</math> of nameplate marking when unit is operating.</li> <li>• Replace - check for correct voltage</li> <li>• Add refrigerant</li> </ul>
Registers sweat	<ul style="list-style-type: none"> <li>• Low evaporator airflow</li> </ul>	<ul style="list-style-type: none"> <li>• Increase speed of blower or reduce restriction - replace air filter</li> </ul>
High head-low vapor pressures	<ul style="list-style-type: none"> <li>• Restriction in liquid line, expansion device or filter drier</li> <li>• Flow check piston size too small</li> <li>• Incorrect capillary tubes</li> <li>• TXV does not open</li> </ul>	<ul style="list-style-type: none"> <li>• Remove or replace defective component</li> <li>• Change to correct size piston</li> <li>• Change coil assembly</li> <li>• Replace TXV</li> </ul>
High head-high or normal vapor pressure - Cooling mode	<ul style="list-style-type: none"> <li>• Dirty condenser coil</li> <li>• Refrigerant overcharge</li> <li>• Condenser fan not running</li> <li>• Air or non-condensibles in system</li> </ul>	<ul style="list-style-type: none"> <li>• Clean coil</li> <li>• Correct system charge</li> <li>• Repair or replace</li> <li>• Recover refrigerant, evacuate &amp; recharge</li> </ul>
High head-high or normal vapor pressure - Heating mode	<ul style="list-style-type: none"> <li>• Low air flow - condenser coil</li> <li>• Refrigerant overcharge</li> <li>• Air or non-condensibles in system</li> <li>• Dirty condenser coil</li> </ul>	<ul style="list-style-type: none"> <li>• Check filters - correct to speed</li> <li>• Correct system charge</li> <li>• Recover refrigerant, evacuate &amp; recharge</li> <li>• Check filter - clean coil</li> </ul>
Low head-high vapor pressures	<ul style="list-style-type: none"> <li>• Defective Compressor valves</li> </ul>	<ul style="list-style-type: none"> <li>• Replace compressor</li> </ul>
Low vapor - cool compressor - iced evaporator coil	<ul style="list-style-type: none"> <li>• Low evaporator airflow</li> <li>• Operating below 65°F outdoors</li> <li>• Moisture in system</li> <li>• TXV limiting refrigerant flow</li> </ul>	<ul style="list-style-type: none"> <li>• Increase speed of blower or reduce restriction - replace air filter</li> <li>• Add Low Ambient Kit</li> <li>• Recover refrigerant - evacuate &amp; recharge - add filter drier</li> <li>• Replace TXV</li> </ul>
High vapor pressure	<ul style="list-style-type: none"> <li>• Excessive load</li> <li>• Defective compressor</li> </ul>	<ul style="list-style-type: none"> <li>• Recheck load calculation</li> <li>• Replace</li> </ul>
Fluctuating head & vapor pressures	<ul style="list-style-type: none"> <li>• TXV hunting</li> <li>• Air or non-condensate in system</li> </ul>	<ul style="list-style-type: none"> <li>• Check TXV bulb clamp - check air distribution on coil - replace TXV</li> <li>• Recover refrigerant, evacuate &amp; recharge</li> </ul>
Gurgle or pulsing noise at expansion device or liquid line	<ul style="list-style-type: none"> <li>• Air or non-condensibles in system</li> </ul>	<ul style="list-style-type: none"> <li>• Recover refrigerant, evacuate &amp; recharge</li> </ul>

