

MOTOR SPEED WIRING

FURNACE INPUT / SIZE	HEAT* (FACTORY)	ALT. HEAT*	COOL (FACTORY)**	CONT FAN (FACTORY)
50K / 14W	Y/2	PR/3	BK/5	R/1
75K / 17W	PR/3	BL/4	BK/5	R/1
75K / 21W	PR/3	BL/4	BK/5	R/1
100K / 21W	Y/2	PR/3	BK/5	R/1
125K / 24W	PR/3	BL/4	BK/5	R/1

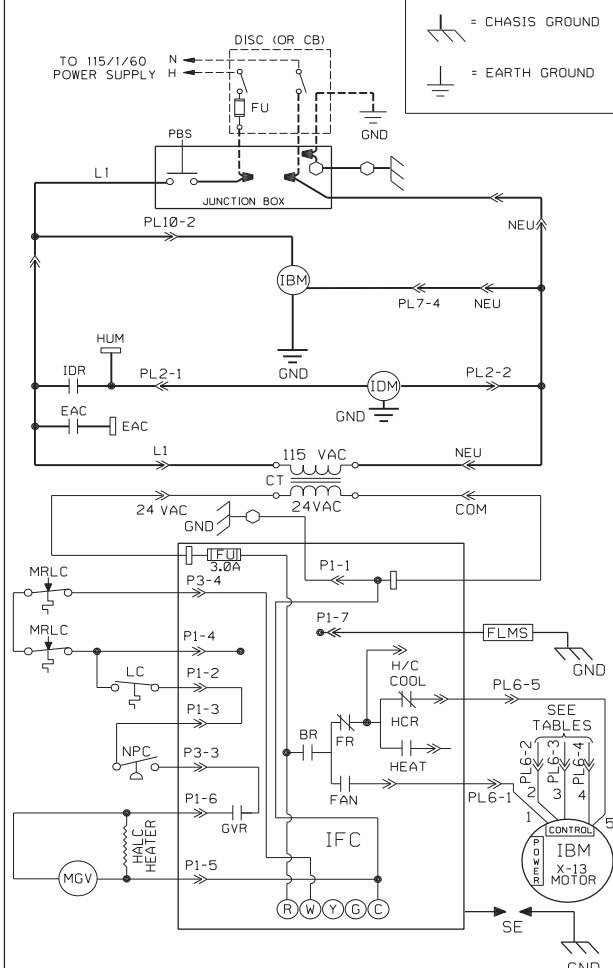
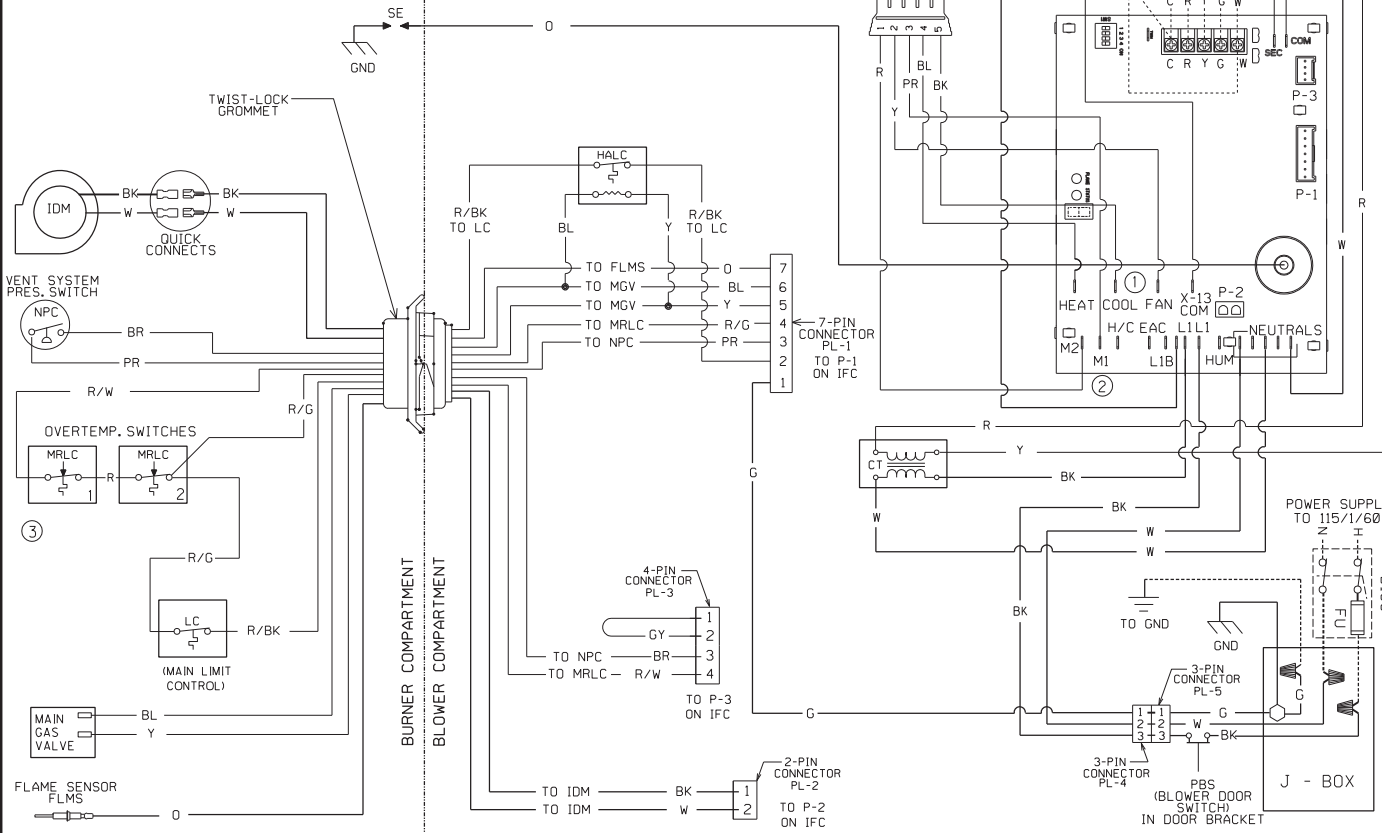

WIRING INFORMATION

LINE VOLTAGE
 -FACTORY STANDARD _____
 -FACTORY OPTION - - - - -
 -FIELD INSTALLED - - - - -

LOW VOLTAGE
 -FACTORY STANDARD _____
 -FACTORY OPTION - - - - -
 -FIELD INSTALLED - - - - -

REPLACEMENT WIRE
 -MUST BE THE SAME SIZE AND TYPE OF INSULATION AS ORIGINAL (105C. MIN.)

WARNING
 -CABINET MUST BE PERMANENTLY GROUND AND CONFORM TO I.E.C., N.E.C., C.E.C., NATIONAL WIRING REGULATIONS, AND LOCAL CODES AS APPLICABLE.

NOTES

① REFER TO SPEC SHEET FOR ACTUAL FACTORY MOTOR TAP PLACEMENT OF "HEAT" & "FAN" AS SOME MODELS MAY BE DIFFERENT THAN SHOWN HERE, ALSO REFER TO SPEC. SHEET OR INSTALLATION MANUAL IF WIRING OF HEAT AND/OR COOL SPEEDS IS NOT DESIRABLE.

② CONNECT UNUSED MOTOR LEADS TO MI AND/OR M2

③ TWO OR THREE MRLC SWITCHES MAY BE PRESENT DEPENDING ON MODEL.

COMPONENT CODES

BLWR	BLOWER RELAY	IFC	INTEGRATED FURNACE CONT
C	COMMON	LC	LIMIT CONTROL
CC	COILING CONTACTOR	LPC	LOW PRESSURE CONTROL
CT	CONTROL TRANSFORMER	M	MAIN
DISC	DISCONNECT SWITCH	MC	MEMORY CARD
EAC	ELECT. AIR CLEANER OUTPUT	MGV	MAIN GAS VALVE
FLMS	FLAME SENSOR	MRLC	MAN. RESET LIMIT CONTROL
FR	FAN RELAY	NEU	NEUTRAL
FU	FUSE	NPC	NEGATIVE PRESSURE CONT.
GND	GROUND	PBS	PUSH BUTTON SWITCH
GVR	GAS VALVE RELAY	PFC	POWER FACTOR CHOKE
HALC	HEAT ASSISTED LIMIT CONTROL	PL	PLUG
HCR	HEAT/COOL RELAY	PS	PRESSURE SWITCH
HPC	HIGH PRESSURE CONTROL	RC	RUN CAPACITOR
HUM	HUMIDIFIER OUTPUT	SE	SPARK ELECTRODE
IBM	INDOOR BLOWER MOTOR	TM	THERMISTOR
IDM	INDUCED DRAFT MOTOR	▲	WIRE NUT
IDR	INDUCED DRAFT RELAY		

WIRE COLOR CODE

BK.....BLACK	G.....GREEN	PR.....PURPLE
BR.....BROWN	GY.....GRAY	R.....RED
BL.....BLUE	O.....ORANGE	W.....WHITE
	Y.....YELLOW	

ELECTRICAL WIRING DIAGRAM
 UPFLOW / HORIZONTAL, BLOWER INDUCED DRAFT, 80 PLUS SINGLE STAGE, CONSTANT TORQUE SELECT - TECH / ENDURA GAS FIRED, FORCED AIR FURNACE.

APPROVED:	CHECKED:	ORIGINAL RELEASE NO.:
MODELED JIM	DATE: 1-27-14	G-1021S009
PART NO.: 90-104961-02		REV: 05