

# INSTALLATION INSTRUCTIONS

## FOR COMBINATION HEATING AND COOLING ROOFTOP UNITS

### RKRL-C SERIES 7.5 & 10 TON

### [26.4 & 35.2 kW]



**⚠️ RECOGNIZE THIS SYMBOL AS AN INDICATION OF IMPORTANT SAFETY INFORMATION!**

**⚠️ WARNING**

IF THE INFORMATION IN THESE INSTRUCTIONS IS NOT FOLLOWED EXACTLY, A FIRE OR EXPLOSION MAY RESULT, CAUSING PROPERTY DAMAGE, PERSONAL INJURY OR DEATH.

**⚠️ WARNING**

THESE INSTRUCTIONS ARE INTENDED AS AN AID TO QUALIFIED SERVICE PERSONNEL FOR PROPER INSTALLATION, ADJUSTMENT AND OPERATION OF THIS UNIT. READ THESE INSTRUCTIONS THOROUGHLY BEFORE ATTEMPTING INSTALLATION OR OPERATION. FAILURE TO FOLLOW THESE INSTRUCTIONS MAY RESULT IN IMPROPER INSTALLATION, ADJUSTMENT, SERVICE OR MAINTENANCE, POSSIBLY RESULTING IN FIRE, ELECTRICAL SHOCK, CARBON MONOXIDE POISONING, EXPLOSION, PROPERTY DAMAGE, PERSONAL INJURY OR DEATH.

**⚠️ WARNING**

PROPOSITION 65 WARNING: THIS PRODUCT CONTAINS CHEMICALS KNOWN TO THE STATE OF CALIFORNIA TO CAUSE CANCER, BIRTH DEFECTS OR OTHER REPRODUCTIVE HARM.

**⚠️ WARNING**

- Do not store or use gasoline or other flammable vapors and liquids, or other combustible materials in the vicinity of this or any other appliance.
- WHAT TO DO IF YOU SMELL GAS
  - Do not try to light any appliance.
  - Do not touch any electrical switch; do not use any phone in your building.
  - Immediately call your gas supplier from a neighbor's phone. Follow the gas supplier's instructions.
  - If you cannot reach your gas supplier, call the fire department.
  - Do not return to your home until authorized by the gas supplier or fire department.
- DO NOT RELY ON SMELL ALONE TO DETECT LEAKS. DUE TO VARIOUS FACTORS, YOU MAY NOT BE ABLE TO SMELL FUEL GASES.
  - U.L. recognized fuel gas and CO detectors are recommended in all applications, and their installation should be in accordance with the manufacturer's recommendations and/or local laws, rules, regulations, or customs.
- Improper installation, adjustment, alteration, service or maintenance can cause injury, property damage or death. Refer to this manual. Installation and service must be performed by a qualified installer, service agency or the gas supplier. In the commonwealth of Massachusetts, installation must be performed by a licensed plumber or gas fitter for appropriate fuel.

**Featuring New Industry  
Standard R-410A**

**R-410A**

**DO NOT DESTROY THIS MANUAL. PLEASE READ CAREFULLY AND KEEP IN A SAFE PLACE FOR FUTURE REFERENCE BY A SERVICEMAN.**

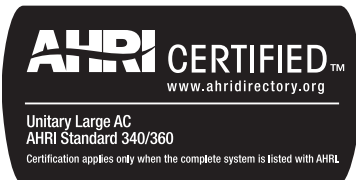

# TABLE OF CONTENTS

	Page No.
<b>INTRODUCTION</b>	2
Checking Product Received	2
<b>I. SPECIFICATIONS</b>	2
General	2
Major Components	2
R-410A Refrigerant	2
Safety Information	3
Unit Dimensions	4-6
General Data	7-13
Electrical Data	14-15
<b>II. INSTALLATION</b>	16
General	16
Location Considerations	16
Outside Installation	16
Exhaust & Combustion	
Air Inlet Hoods	17
Cover Panel Installation	17
Filter Replacement	17
Clearances	18
Rooftop Installation	19
Ducting	19
Return Air	20
<b>III. GAS SUPPLY &amp; PIPING</b>	21
Gas Connection	21
LP Conversion	22
Adjusting or Checking	
Furnace Input	22
Condensate Drain	23
<b>IV. WIRING</b>	24
Power Supply	24
Hook-up	25
Internal Wiring	25
Thermostat	25
<b>V. FURNACE CONTROLS</b>	26
Operating Sequence	26
Operating Instructions	26
Burners	27
Manual Reset	27
Pressure Switch	27
Limit Control	27
<b>VI. OPERATION INFO</b>	27
Advise Customer	27
Furnace Maintenance	27
Lubrication	28
Cooling Maintenance	28
Replacement Parts	28
Troubleshooting	28
Wiring Diagrams	28
Charging	28
<b>VII. AIRFLOW PERFORMANCE</b>	29-30
<b>VIII. TROUBLESHOOTING</b>	31-33
<b>IX. WIRING DIAGRAMS</b>	34-37
<b>X. CHARGE CHARTS</b>	38-39

# INTRODUCTION

## ▲ WARNING

**THE MANUFACTURER'S WARRANTY DOES NOT COVER ANY DAMAGE OR DEFECT TO THE AIR CONDITIONER CAUSED BY THE ATTACHMENT OR USE OF ANY COMPONENTS, ACCESSORIES OR DEVICES (OTHER THAN THOSE AUTHORIZED BY THE MANUFACTURER) INTO, ONTO OR IN CONJUNCTION WITH THE AIR CONDITIONER. YOU SHOULD BE AWARE THAT THE USE OF UNAUTHORIZED COMPONENTS, ACCESSORIES OR DEVICES MAY ADVERSELY AFFECT THE OPERATION OF THE AIR CONDITIONER AND MAY ALSO ENDANGER LIFE AND PROPERTY. THE MANUFACTURER DISCLAIMS ANY RESPONSIBILITY FOR SUCH LOSS OR INJURY RESULTING FROM THE USE OF SUCH UNAUTHORIZED COMPONENTS, ACCESSORIES OR DEVICES.**

This booklet contains the installation and operating instructions for your combination gas heating/electric cooling unit. There are some precautions that should be taken to derive maximum satisfaction from it. Improper installation can result in unsatisfactory operation or dangerous conditions.

Read this booklet and any instructions packaged with separate equipment required to make up the system prior to installation. Give this booklet to the owner and explain its provisions. The owner should retain this booklet for future reference.

## CHECKING PRODUCT RECEIVED

Upon receiving the unit, inspect it for any damage from shipment. Claims for damage, either shipping or concealed, should be filed immediately with the shipping company. **IMPORTANT:** Check the unit model number, heating size, electrical characteristics, and accessories to determine if they are correct.

## I. SPECIFICATIONS

### A. GENERAL

The Combination Gas Heating/Electric Cooling Rooftop is available in 150,000, 225,000 and 252,000 BTUH heating input. Cooling capacity is 6, 7.5, 8.5, 10, 12.5 nominal tons. Units are convertible from bottom supply and return to side supply and return by relocation of supply and return air cover panels. See cover installation detail.

The units are weatherized for mounting outside of the building.

## ▲ WARNING

**UNITS ARE NOT DESIGN CERTIFIED TO BE INSTALLED INSIDE THE STRUCTURE. DOING SO CAN CAUSE INADEQUATE UNIT PERFORMANCE AS WELL AS PROPERTY DAMAGE AND CARBON MONOXIDE POISONING RESULTING IN PERSONAL INJURY OR DEATH.**

The information on the rating plate is in compliance with the FTC and DOE rating for single phase units. The following information is for three phase units which **are not** covered under the DOE certification program.

1. The energy consumption of the ignition system used with this unit is 175 watts.
2. The efficiency rating of this unit is a product thermal efficiency rating determined under continuous operating conditions independent of any installed system.

## B. MAJOR COMPONENTS

The unit includes a hermetically-sealed refrigerating system consisting of a scroll compressor, condenser coil, evaporator coil with fixed restrictor assembly or TXV, a circulation air blower, a condenser fan, a heat exchanger assembly, gas burner and control assembly, combustion air motor and fan, and all necessary internal electrical wiring. The cooling system of these units is factory-evacuated, charged and performance tested. Refrigerant amount and type are indicated on rating plate.

## C. R-410A REFRIGERANT

All units are factory charged with R-410A refrigerant.

### 1. Specifications of R-410A:

**Application:** R-410A is not a drop-in replacement for R-22; equipment designs must accommodate its higher pressures. It cannot be retrofitted into R-22 units.

**Pressure:** The pressure of R-410A is approximately 60% (1.6 times) greater than R-22. Recovery and recycle

equipment, pumps, hoses, and the like need to have design pressure ratings appropriate for R-410A. *Manifold sets need to range up to 800 psig high-side and 250 psig low-side with a 550 psig low-side retard. Hoses need to have a service pressure rating of 800 psig. Recovery cylinders need to have a 400 psig service pressure rating. DOT 4BA400 or DOT BW400.*

**Combustibility:** At pressures above 1 atmosphere, mixture of R-410A and air can become combustible. R-410A and air should never be mixed in tanks or supply lines, or be allowed to accumulate in storage tanks. Leak checking should

**never be done with a mixture of R-410A and air.** Leak checking can be performed safely with nitrogen or a mixture of R-410A and nitrogen.

## 2. Quick Reference Guide For R-410A

- R-410A refrigerant operates at approximately 60% higher pressure (1.6 times) than R-22. Ensure that servicing equipment is designed to operate with R-410A.
- R-410A refrigerant cylinders are pink.
- R-410A, as with other HFC's is only compatible with POE oils.
- Vacuum pumps will not remove moisture from POE oil.
- R-410A systems are to be charged with liquid refrigerants. Prior to March 1999, R-410A refrigerant cylinders had a dip

tube. These cylinders should be kept upright for equipment charging. Post March 1999 cylinders do not have a dip tube and should be inverted to ensure liquid charging of the equipment.

- Do not install a suction line filter drier in the liquid line.
- A liquid line filter drier is standard on every unit.
- Desiccant (drying agent) must be compatible for POE oils and R-410A.

## 3. Evaporator Coil/TXV

The thermostatic expansion valve is specifically designed to operate with R-410A. **DO NOT use an R-22 TXV. The existing evaporator must be replaced with the factory specified TXV evaporator specifically designed for R-410A.**

## 4. Tools Required For Installing & Servicing R-410A Models

Manifold Sets:

- Up to 800 PSIG High Side
- Up to 250 PSIG Low Side
- 550 PSIG Low Side Retard

Manifold Hoses:

- Service Pressure Rating of 800 PSIG

Recovery Cylinders:

- 400 PSIG Pressure Rating
- Dept. of Transportation 4BA400 or BW400

### ▲ CAUTION

R-410A SYSTEMS OPERATE AT HIGHER PRESSURE THAN R-22 SYSTEMS. DO NOT USE R-22 SERVICE EQUIPMENT OR COMPONENTS ON R-410A EQUIPMENT.

# SAFETY INFORMATION

### ▲ WARNING

USE ONLY WITH TYPE OF GAS APPROVED FOR THIS UNIT. REFER TO THE UNIT RATING PLATE.

### ▲ WARNING

INSTALL THIS UNIT ONLY IN A LOCATION AND POSITION AS SPECIFIED IN THE LOCATION REQUIREMENTS AND CONSIDERATIONS SECTION OF THESE INSTRUCTIONS. PROVIDE ADEQUATE COMBUSTION AND VENTILATION AIR TO THE UNIT SPACE AS SPECIFIED IN THE VENTING SECTION OF THESE INSTRUCTIONS.

### ▲ WARNING

PROVIDE ADEQUATE COMBUSTION AND VENTILATION AIR TO THE UNIT SPACE AS SPECIFIED IN THE COMBUSTION AND VENTILATION AIR SECTION OF THESE INSTRUCTIONS.

### ▲ WARNING

COMBUSTION PRODUCTS MUST BE DISCHARGED OUTDOORS. CONNECT THE FACTORY SUPPLIED EXHAUST AND COMBUSTION AIR INLET HOODS ONLY, AS SPECIFIED IN THE EXHAUST AND COMBUSTION AIR INLET HOODS INSTALLATION SECTION OF THESE INSTRUCTIONS.

### ▲ WARNING

NEVER TEST FOR GAS LEAKS WITH AN OPEN FLAME. USE A COMMERCIALY AVAILABLE SOAP SOLUTION MADE SPECIFICALLY FOR THE DETECTION OF LEAKS TO CHECK ALL CONNECTIONS, AS SPECIFIED IN GAS SUPPLY AND PIPING SECTION OF THESE INSTRUCTIONS.

### ▲ WARNING

ALWAYS INSTALL UNIT TO OPERATE WITHIN THE UNIT'S INTENDED TEMPERATURE-RISE RANGE WITH A DUCT SYSTEM WHICH HAS AN EXTERNAL STATIC PRESSURE WITHIN THE ALLOWABLE RANGE, AS SPECIFIED IN DUCTING SECTION OF THESE INSTRUCTIONS. SEE ALSO UNIT RATING PLATE.

### ▲ WARNING

WHEN A UNIT IS INSTALLED SO THAT SUPPLY DUCTS CARRY AIR CIRCULATED BY THE UNIT TO AREAS OUTSIDE THE SPACE CONTAINING THE UNIT, THE RETURN AIR SHALL ALSO BE HANDLED BY DUCT(S) SEALED TO THE UNIT CASING AND TERMINATING OUTSIDE THE SPACE CONTAINING THE UNIT.

### ▲ WARNING

THIS UNIT MAY BE USED TO HEAT THE BUILDING OR STRUCTURE DURING CONSTRUCTION IF THE FOLLOWING INSTALLATION REQUIREMENTS ARE MET. INSTALLATION MUST COMPLY WITH ALL INSTALLATION INSTRUCTIONS INCLUDING:

- PROPER VENT INSTALLATION;
- FURNACE OPERATING UNDER THERMOSTATIC CONTROL;
- RETURN AIR DUCT SEALED TO THE FURNACE;
- AIR FILTERS IN PLACE;
- SET FURNACE INPUT RATE AND TEMPERATURE RISE PER RATING PLATE MARKING;
- RETURN AIR TEMPERATURE MAINTAINED BETWEEN 55°F (13°C) AND 80°F (27°C); AND
- INSTALLATION OF EXHAUST AND COMBUSTION AIR INLET HOODS COMPLETED;
- CLEAN FURNACE, DUCT WORK AND COMPONENTS UPON SUBSTANTIAL COMPLETION OF THE CONSTRUCTION PROCESS, AND VERIFY FURNACE OPERATING CONDITIONS INCLUDING IGNITION INPUT RATE, TEMPERATURE RISE AND VENTING, ACCORDING TO THE INSTRUCTIONS.

# Unit Dimensions

**IMPORTANT: THIS UNIT MUST BE MOUNTED LEVEL IN BOTH DIRECTIONS TO ALLOW WATER TO DRAIN FROM THE CONDENSER SECTION AND CONDENSATE PAN.**

**FIGURE 1  
BOTTOM VIEW**

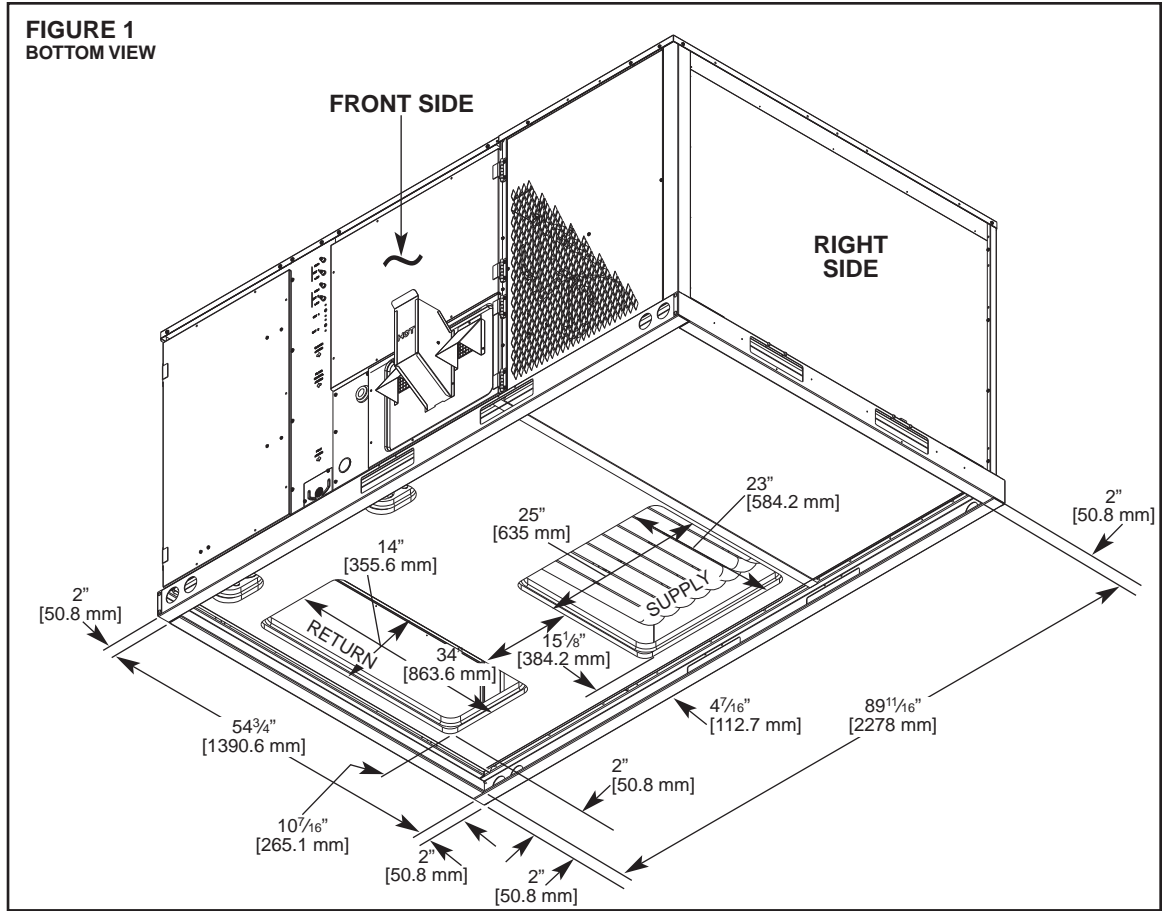

**FIGURE 2  
CABINET DIMENSIONS  
AND ACCESS LOCATIONS**

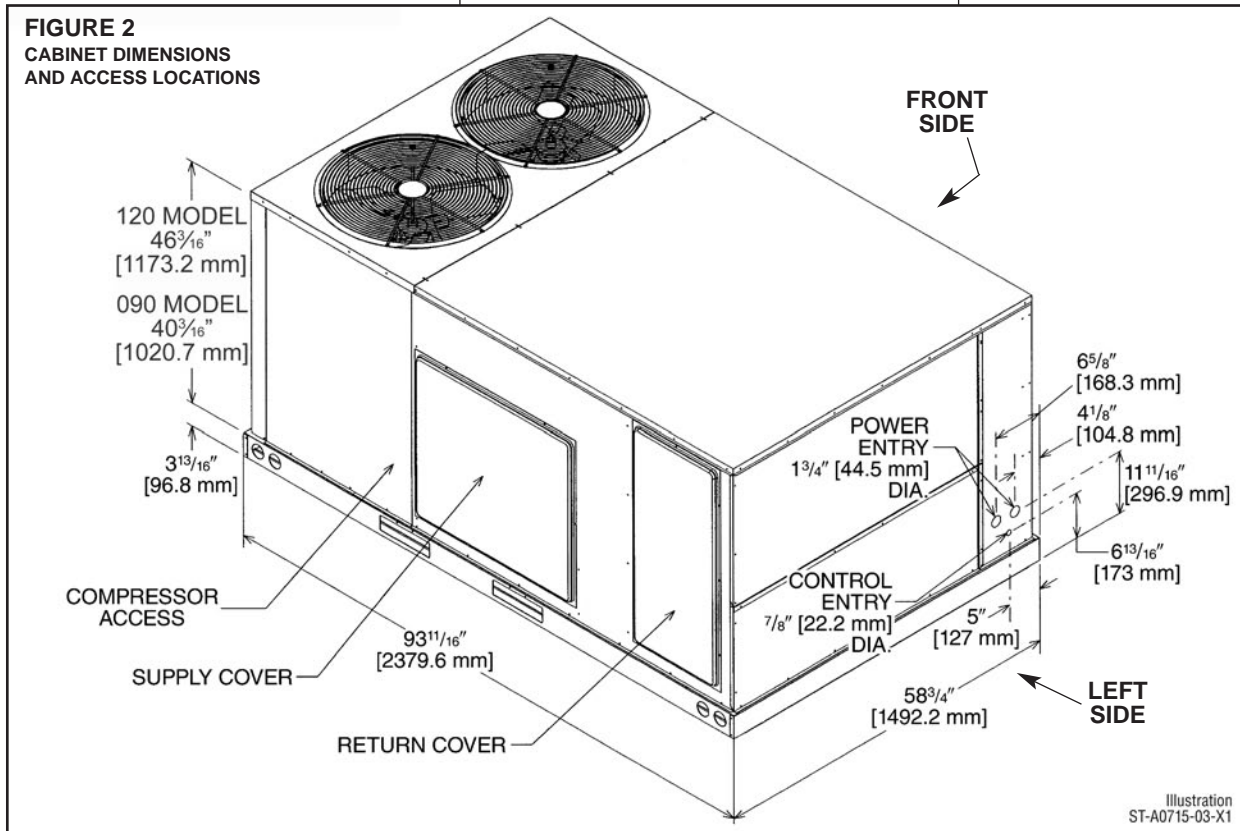
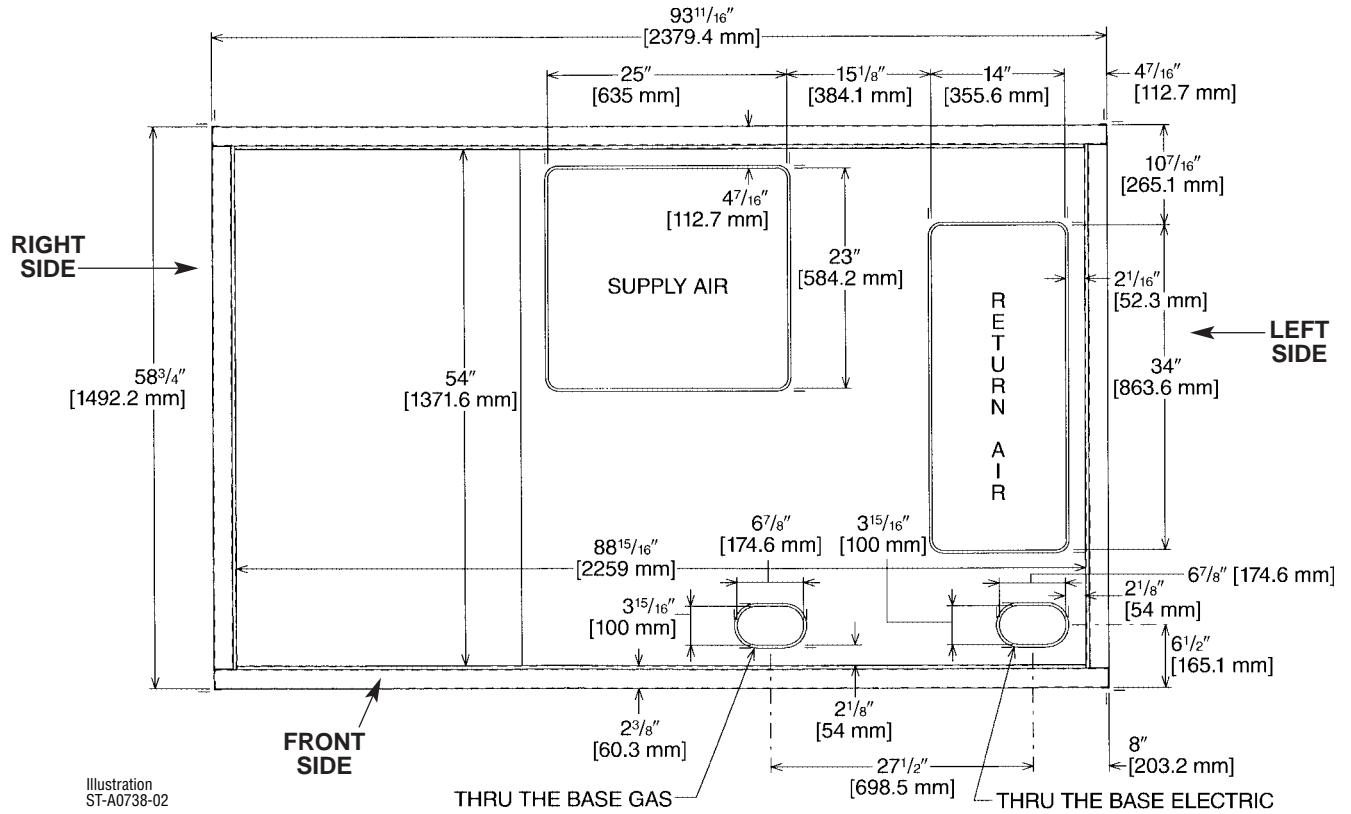
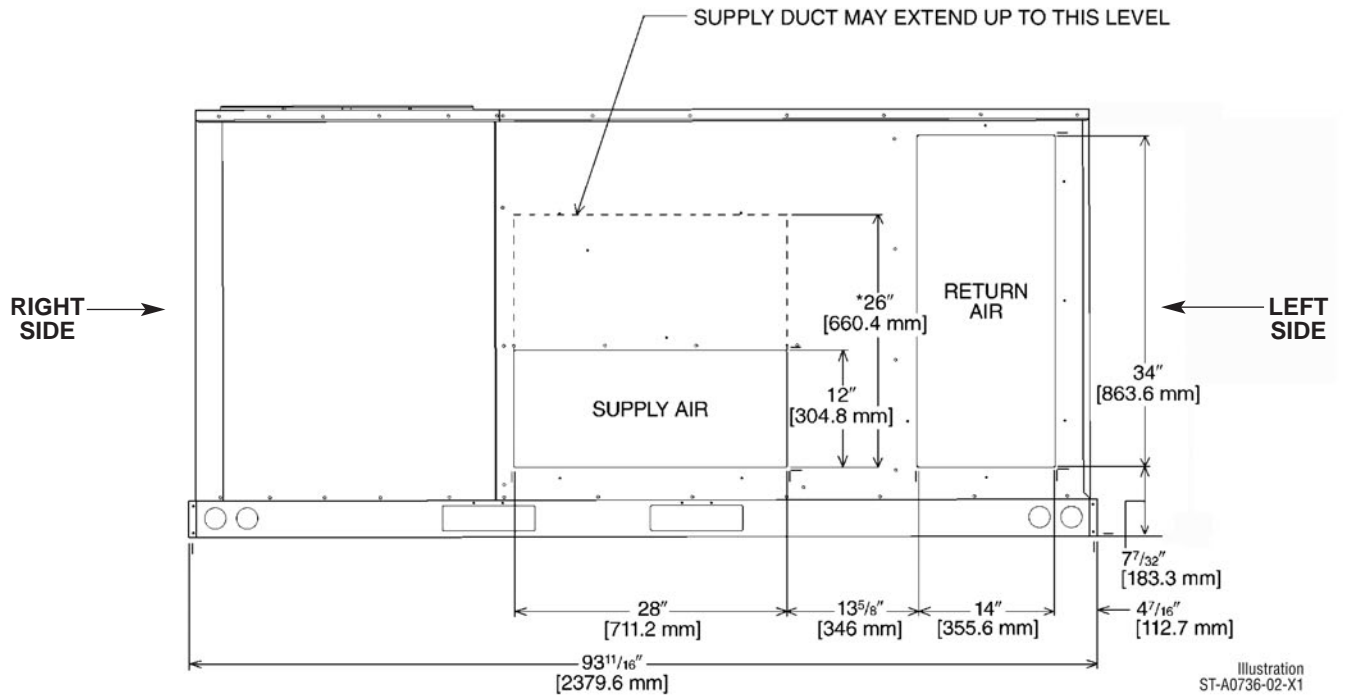

Illustration  
ST-A0715-03-X1

**FIGURE 3**  
**SUPPLY AND RETURN DIMENSIONS FOR DOWNFLOW APPLICATIONS** (BOTTOM VIEW)



**FIGURE 4**  
**SUPPLY AND RETURN DIMENSIONS FOR HORIZONTAL APPLICATIONS** (SIDE VIEW – REAR)



**FIGURE 5**

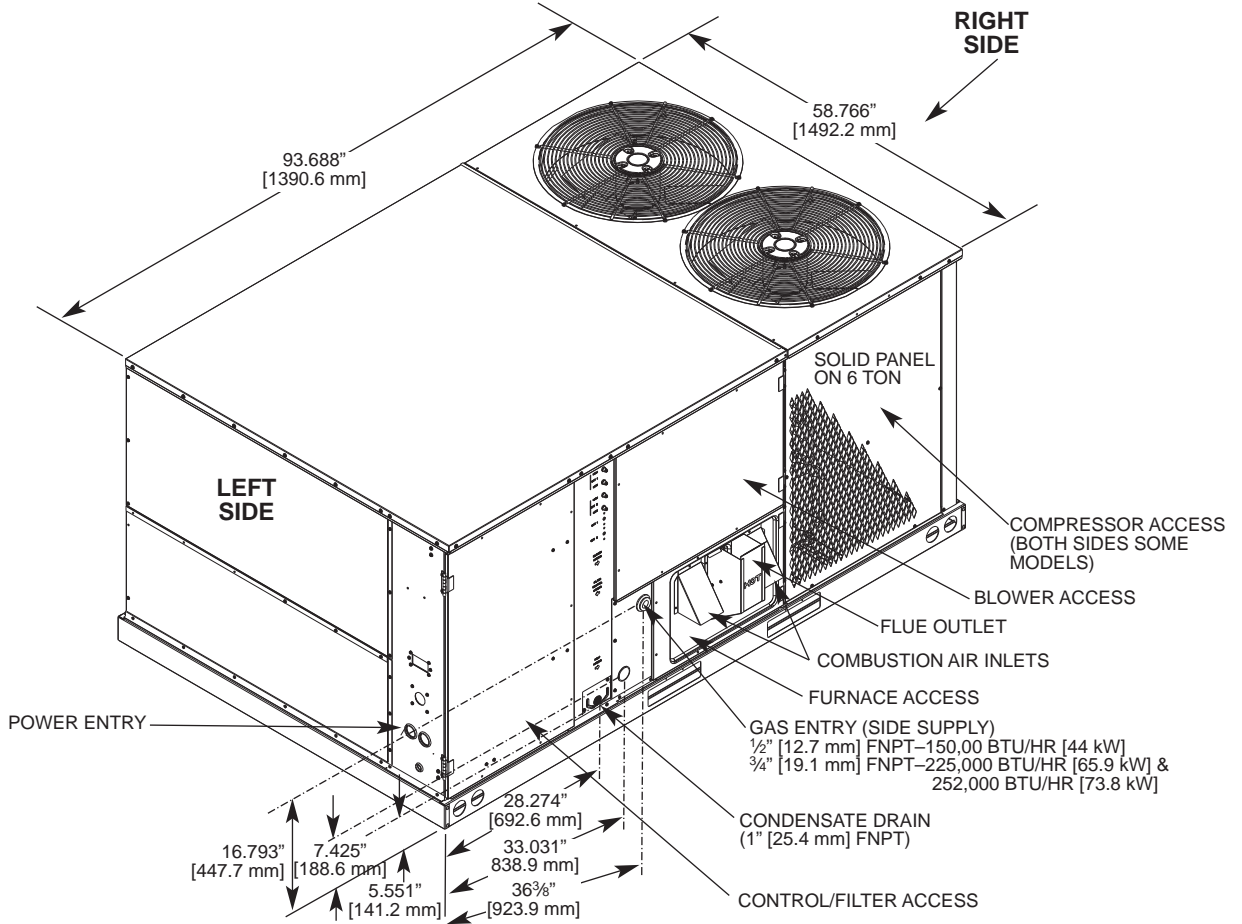

**FIGURE 6  
ROOFCURB INSTALLATION**

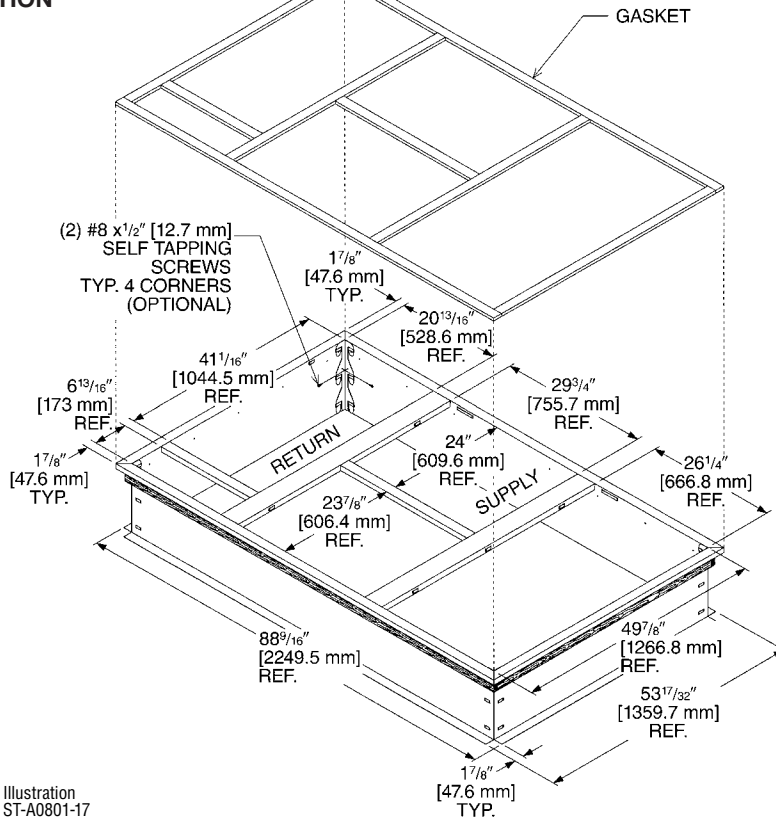

# GENERAL DATA - RKRL MODELS

## NOM. SIZES 7.5-10 TON [26.4 - 35.2 kW]

Model RKRL-Series	C090CL15E	C090CL22E	C090CM15E	C090CM22E
<b>Cooling Performance<sup>1</sup></b>				
Gross Cooling Capacity Btu [kW]	95,000 [27.83]	95,000 [27.83]	95,000 [27.83]	95,000 [27.83]
EER/SEER <sup>2</sup>	13/NA	13/NA	13/NA	13/NA
Nominal CFM/AHRI Rated CFM [L/s]	3000/2600 [1416/1227]	3000/2600 [1416/1227]	3000/2600 [1416/1227]	3000/2600 [1416/1227]
AHRI Net Cooling Capacity Btu [kW]	92,000 [26.96]	92,000 [26.96]	92,000 [26.96]	92,000 [26.96]
Net Sensible Capacity Btu [kW]	66,200 [19.4]	66,200 [19.4]	66,200 [19.4]	66,200 [19.4]
Net Latent Capacity Btu [kW]	25,800 [7.56]	25,800 [7.56]	25,800 [7.56]	25,800 [7.56]
IEER <sup>3</sup>	14.0	14.0	14.0	14.0
Net System Power kW	7.04	7.04	7.04	7.04
<b>Heating Performance (Gas)<sup>4</sup></b>				
Heating Input Btu [kW] (1st Stage / 2nd Stage)	75,000/150,000 [21.97/43.95]	112,500/225,000 [32.96/65.92]	75,000/150,000 [21.97/43.95]	112,500/225,000 [32.96/65.92]
Heating Output Btu [kW] (1st Stage / 2nd Stage)	60,750/121,500 [17.8/35.6]	91,125/182,250 [26.7/53.4]	60,750/121,500 [17.8/35.6]	91,125/182,250 [26.7/53.4]
Temperature Rise Range °F [°C] (1st Stage / 2nd Stage)	25-55 [13.9-30.6] / 25-55 [13.9/30.6]	40-70 [22.2-38.9] / 40-70 [22.2-38.9]	25-55 [13.9-30.6] / 25-55 [13.9/30.6]	40-70 [22.2-38.9] / 40-70 [22.2-38.9]
Steady State Efficiency (%)	81	81	81	81
No. Burners	6	9	6	9
No. Stages	2	2	2	2
Gas Connection Pipe Size in. [mm]	0.5 [12.7]	0.75 [19.05]	0.5 [12.7]	0.75 [19]
<b>Compressor</b>				
No./Type	2/Scroll	2/Scroll	2/Scroll	2/Scroll
<b>Outdoor Sound Rating (dB)<sup>5</sup></b>				
	88	88	88	88
<b>Outdoor Coil—Fin Type</b>				
Tube Type	Louvered MicroChannel	Louvered MicroChannel	Louvered MicroChannel	Louvered MicroChannel
Tube Size in. [mm] OD	1 [25.4]	1 [25.4]	1 [25.4]	1 [25.4]
Face Area sq. ft. [sq. m]	27 [2.51]	27 [2.51]	27 [2.51]	27 [2.51]
Rows / FPI [FPcm]	1 / 23 [9]	1 / 23 [9]	1 / 23 [9]	1 / 23 [9]
<b>Indoor Coil—Fin Type</b>				
Tube Type	Louvered Rifled	Louvered Rifled	Louvered Rifled	Louvered Rifled
Tube Size in. [mm]	0.375 [9.5]	0.375 [9.5]	0.375 [9.5]	0.375 [9.5]
Face Area sq. ft. [sq. m]	13.5 [1.25]	13.5 [1.25]	13.5 [1.25]	13.5 [1.25]
Rows / FPI [FPcm]	3 / 15 [6]	3 / 15 [6]	3 / 15 [6]	3 / 15 [6]
Refrigerant Control	TX Valves	TX Valves	TX Valves	TX Valves
Drain Connection No./Size in. [mm]	1/1 [25.4]	1/1 [25.4]	1/1 [25.4]	1/1 [25.4]
<b>Outdoor Fan—Type</b>				
No. Used/Diameter in. [mm]	2/24 [609.6]	2/24 [609.6]	2/24 [609.6]	2/24 [609.6]
Drive Type/No. Speeds	Direct/1	Direct/1	Direct/1	Direct/1
CFM [L/s]	8000 [3775]	8000 [3775]	8000 [3775]	8000 [3775]
No. Motors/HP	2 at 1/3 HP	2 at 1/3 HP	2 at 1/3 HP	2 at 1/3 HP
Motor RPM	1075	1075	1075	1075
<b>Indoor Fan—Type</b>				
No. Used/Diameter in. [mm]	FC Centrifugal 1/15x15 [381x381]	FC Centrifugal 1/15x15 [381x381]	FC Centrifugal 1/15x15 [381x381]	FC Centrifugal 1/15x15 [381x381]
Drive Type/No. Speeds	Belt/Variable	Belt/Variable	Belt/Variable	Belt/Variable
No. Motors	1	1	1	1
Motor HP	2	2	2	2
Motor RPM	1725	1725	1725	1725
Motor Frame Size	56	56	56	56
<b>Filter—Type</b>				
Furnished	Disposable Yes	Disposable Yes	Disposable Yes	Disposable Yes
(NO.) Size Recommended in. [mm x mm x mm]	(6)2x18x18 [51x457x457]	(6)2x18x18 [51x457x457]	(6)2x18x18 [51x457x457]	(6)2x18x18 [51x457x457]
<b>Refrigerant Charge Oz. (Sys. 1/Sys. 2) [g]</b>				
	105.6/105.6 [2994/2994]	105.6/105.6 [2994/2994]	105.6/105.6 [2994/2994]	105.6/105.6 [2994/2994]
<b>Weights</b>				
Net Weights lbs. [kg]	1056 [479]	1092 [495]	1056 [479]	1092 [495]
Ship Weights lbs. [kg]	1093 [496]	1129 [512]	1093 [496]	1129 [512]

### NOTES:

- Cooling Performance is rated at 95° F ambient, 80° F entering dry bulb, 67° F entering wet bulb. Gross capacity does not include the effect of fan motor heat. AHRI capacity is net and includes the effect of fan motor heat. Units are suitable for operation to 20% of nominal cfm. Units are certified in accordance with the Unitary Air Conditioner Equipment certification program, which is based on AHRI Standard 340/360.
- EER and/or SEER are rated at AHRI conditions and in accordance with DOE test procedures.
- IEER is rated in accordance with AHRI Standard 340/360. Units are rated at 80° F ambient, 80° F entering dry bulb, and 67° F entering wet bulb at ARI rated cfm.
- Heating Performance limit settings and rating data were established and approved under laboratory test conditions using American National Standard Institute standards. Ratings shown are for elevations up to 2000 feet. For elevations above 2000 feet, ratings should be reduced at the rate of 4% for each 1000 feet above sea level.
- Outdoor Sound Rating shown is tested in accordance with AHRI Standard 270.

# GENERAL DATA - RKRL MODELS

## NOM. SIZES 7.5-10 TON [26.4 - 35.2 kW]

Model RKRL-Series	C090CN15E	C090CN22E	C090DL15E	C090DL22E
<b>Cooling Performance<sup>1</sup></b>				<b>CONTINUED</b> →
Gross Cooling Capacity Btu [kW]	95,000 [27.83]	95,000 [27.83]	95,000 [27.83]	95,000 [27.83]
EER/SEER <sup>2</sup>	13/NA	13/NA	13/NA	13/NA
Nominal CFM/AHRI Rated CFM [L/s]	3000/2600 [1416/1227]	3000/2600 [1416/1227]	3000/2600 [1416/1227]	3000/2600 [1416/1227]
AHRI Net Cooling Capacity Btu [kW]	92,000 [26.96]	92,000 [26.96]	92,000 [26.96]	92,000 [26.96]
Net Sensible Capacity Btu [kW]	66,200 [19.4]	66,200 [19.4]	66,200 [19.4]	66,200 [19.4]
Net Latent Capacity Btu [kW]	25,800 [7.56]	25,800 [7.56]	25,800 [7.56]	25,800 [7.56]
IEER <sup>3</sup>	14	14	14	14
Net System Power kW	7.04	7.04	7.04	7.04
<b>Heating Performance (Gas)<sup>4</sup></b>				
Heating Input Btu [kW] (1st Stage / 2nd Stage)	75,000/150,000 [21.97/43.95]	112,500/225,000 [32.96/65.92]	75,000/150,000 [21.97/43.95]	112,500/225,000 [32.96/65.92]
Heating Output Btu [kW] (1st Stage / 2nd Stage)	60,750/121,500 [17.8/35.6]	91,125/182,250 [26.7/53.4]	60,750/121,500 [17.8/35.6]	91,125/182,250 [26.7/53.4]
Temperature Rise Range °F [°C] (1st Stage / 2nd Stage)	25-55 [13.9-30.6] / 25-55 [13.9/30.6]	40-70 [22.2-38.9] / 40-70 [22.2-38.9]	25-55 [13.9-30.6] / 25-55 [13.9/30.6]	40-70 [22.2-38.9] / 40-70 [22.2-38.9]
Steady State Efficiency (%)	81	81	81	81
No. Burners	6	9	6	9
No. Stages	2	2	2	2
Gas Connection Pipe Size in. [mm]	0.5 [12.7]	0.75 [19]	0.75 [19]	0.75 [19]
<b>Compressor</b>				
No./Type	2/Scroll	2/Scroll	2/Scroll	2/Scroll
<b>Outdoor Sound Rating (dB)<sup>5</sup></b>	88	88	88	88
<b>Outdoor Coil—Fin Type</b>	Louvered	Louvered	Louvered	Louvered
Tube Type	MicroChannel	MicroChannel	MicroChannel	MicroChannel
Tube Size in. [mm] OD	1 [25.4]	1 [25.4]	1 [25.4]	1 [25.4]
Face Area sq. ft. [sq. m]	27 [2.51]	27 [2.51]	27 [2.51]	27 [2.51]
Rows / FPI [FPcm]	1 / 23 [9]	1 / 23 [9]	1 / 23 [9]	1 / 23 [9]
<b>Indoor Coil—Fin Type</b>	Louvered	Louvered	Louvered	Louvered
Tube Type	Rifled	Rifled	Rifled	Rifled
Tube Size in. [mm]	0.375 [9.5]	0.375 [9.5]	0.375 [9.5]	0.375 [9.5]
Face Area sq. ft. [sq. m]	13.5 [1.25]	13.5 [1.25]	13.5 [1.25]	13.5 [1.25]
Rows / FPI [FPcm]	3 / 15 [6]	3 / 15 [6]	3 / 15 [7]	3 / 15 [6]
Refrigerant Control	TX Valves	TX Valves	TX Valves	TX Valves
Drain Connection No./Size in. [mm]	1/1 [25.4]	1/1 [25.4]	1/1 [25.4]	1/1 [25.4]
<b>Outdoor Fan—Type</b>	Propeller	Propeller	Propeller	Propeller
No. Used/Diameter in. [mm]	2/24 [609.6]	2/24 [609.6]	2/24 [609.6]	2/24 [609.6]
Drive Type/No. Speeds	Direct/1	Direct/1	Direct/1	Direct/1
CFM [L/s]	8000 [3775]	8000 [3775]	8000 [3775]	8000 [3775]
No. Motors/HP	2 at 1/3 HP	2 at 1/3 HP	2 at 1/3 HP	2 at 1/3 HP
Motor RPM	1075	1075	1075	1075
<b>Indoor Fan—Type</b>	FC Centrifugal	FC Centrifugal	FC Centrifugal	FC Centrifugal
No. Used/Diameter in. [mm]	1/15x15 [381x381]	1/15x15 [381x381]	1/15x15 [381x381]	1/15x15 [381x381]
Drive Type/No. Speeds	Belt/Variable	Belt/Variable	Belt/Variable	Belt/Variable
No. Motors	1	1	1	1
Motor HP	3	2	2	2
Motor RPM	1725	1725	1725	1725
Motor Frame Size	56	56	56	56
<b>Filter—Type</b>	Disposable	Disposable	Disposable	Disposable
Furnished	Yes	Yes	Yes	Yes
(NO.) Size Recommended in. [mm x mm x mm]	(6)2x18x18 [51x457x457]	(6)2x18x18 [51x457x457]	(6)2x18x18 [51x457x457]	(6)2x18x18 [51x457x457]
<b>Refrigerant Charge Oz. (Sys. 1/Sys. 2) [g]</b>	105.6/105.6 [2994/2994]	105.6/105.6 [2994/2994]	105.6/105.6 [2994/2994]	105.6/105.6 [2994/2994]
<b>Weights</b>				
Net Weights lbs. [kg]	1064 [483]	1100 [499]	1056 [479]	1092 [495]
Ship Weights lbs. [kg]	1101 [499]	1137 [516]	1093 [496]	1129 [512]

- NOTES:**
- Cooling Performance is rated at 95° F ambient, 80° F entering dry bulb, 67° F entering wet bulb. Gross capacity does not include the effect of fan motor heat. AHRI capacity is net and includes the effect of fan motor heat. Units are suitable for operation to 20% of nominal cfm. Units are certified in accordance with the Unitary Air Conditioner Equipment certification program, which is based on AHRI Standard 340/360.
  - EER and/or SEER are rated at AHRI conditions and in accordance with DOE test procedures.
  - IEER is rated in accordance with AHRI Standard 340/360. Units are rated at 80° F ambient, 80° F entering dry bulb, and 67° F entering wet bulb at ARI rated cfm.
  - Heating Performance limit settings and rating data were established and approved under laboratory test conditions using American National Standard Institute standards. Ratings shown are for elevations up to 2000 feet. For elevations above 2000 feet, ratings should be reduced at the rate of 4% for each 1000 feet above sea level.
  - Outdoor Sound Rating shown is tested in accordance with AHRI Standard 270.



# GENERAL DATA - RKRL MODELS

## NOM. SIZES 7.5-10 TON [26.4 - 35.2 kW]

Model RKRL-Series	C090DM15E	C090DM22E	C090DN15E	C090DN22E
<b>Cooling Performance<sup>1</sup></b>				<b>CONTINUED</b> →
Gross Cooling Capacity Btu [kW]	95,000 [27.83]	95,000 [27.83]	95,000 [27.83]	95,000 [27.83]
EER/SEER <sup>2</sup>	13/NA	13/NA	13/NA	13/NA
Nominal CFM/AHRI Rated CFM [L/s]	3000/2600 [1416/1227]	3000/2600 [1416/1227]	3000/2600 [1416/1227]	3000/2600 [1416/1227]
AHRI Net Cooling Capacity Btu [kW]	92,000 [26.96]	92,000 [26.96]	92,000 [26.96]	92,000 [26.96]
Net Sensible Capacity Btu [kW]	66,200 [19.4]	66,200 [19.4]	66,200 [19.4]	66,200 [19.4]
Net Latent Capacity Btu [kW]	25,800 [7.56]	25,800 [7.56]	25,800 [7.56]	25,800 [7.56]
IEER <sup>3</sup>	14	14	14	14
Net System Power kW	7.04	7.04	7.04	7.04
<b>Heating Performance (Gas)<sup>4</sup></b>				
Heating Input Btu [kW] (1st Stage / 2nd Stage)	75,000/150,000 [21.97/43.95]	112,500/225,000 [32.96/65.92]	75,000/150,000 [21.97/43.95]	112,500/225,000 [32.96/65.92]
Heating Output Btu [kW] (1st Stage / 2nd Stage)	60,750/121,500 [17.8/35.6]	91,125/182,250 [26.7/53.4]	60,750/121,500 [17.8/35.6]	91,125/182,250 [26.7/53.4]
Temperature Rise Range °F [°C] (1st Stage / 2nd Stage)	25-55 [13.9-30.6] / 25-55 [13.9/30.6]	40-70 [22.2-38.9] / 40-70 [22.2-38.9]	25-55 [13.9-30.6] / 25-55 [13.9/30.6]	40-70 [22.2-38.9] / 40-70 [22.2-38.9]
Steady State Efficiency (%)	81	81	81	81
No. Burners	6	9	6	9
No. Stages	2	2	2	2
Gas Connection Pipe Size in. [mm]	0.5 [12.7]	0.75 [19]	0.5 [12.7]	0.75 [19]
<b>Compressor</b>				
No./Type	2/Scroll	2/Scroll	2/Scroll	2/Scroll
<b>Outdoor Sound Rating (dB)<sup>5</sup></b>				
	88	88	88	88
<b>Outdoor Coil—Fin Type</b>				
Tube Type	Louvered	Louvered	Louvered	Louvered
Tube Size in. [mm] OD	MicroChannel	MicroChannel	MicroChannel	MicroChannel
Face Area sq. ft. [sq. m]	1 [25.4]	1 [25.4]	1 [25.4]	1 [25.4]
Rows / FPI [FPcm]	27 [2.51]	27 [2.51]	27 [2.51]	27 [2.51]
	1 / 23 [9]	1 / 23 [9]	1 / 23 [9]	1 / 23 [9]
<b>Indoor Coil—Fin Type</b>				
Tube Type	Louvered	Louvered	Louvered	Louvered
Tube Size in. [mm]	Rifled	Rifled	Rifled	Rifled
Face Area sq. ft. [sq. m]	0.375 [9.5]	0.375 [9.5]	0.375 [9.5]	0.375 [9.5]
Rows / FPI [FPcm]	13.5 [1.25]	13.5 [1.25]	13.5 [1.25]	13.5 [1.25]
	3 / 15 [6]	3 / 15 [6]	3 / 15 [6]	3 / 15 [6]
Refrigerant Control	TX Valves	TX Valves	TX Valves	TX Valves
Drain Connection No./Size in. [mm]	1/1 [25.4]	1/1 [25.4]	1/1 [25.4]	1/1 [25.4]
<b>Outdoor Fan—Type</b>				
No. Used/Diameter in. [mm]	Propeller	Propeller	Propeller	Propeller
Drive Type/No. Speeds	2/24 [609.6]	2/24 [609.6]	2/24 [609.6]	2/24 [609.6]
CFM [L/s]	Direct/1	Direct/1	Direct/1	Direct/1
No. Motors/HP	8000 [3775]	8000 [3775]	8000 [3775]	8000 [3775]
Motor RPM	2 at 1/3 HP	2 at 1/3 HP	2 at 1/3 HP	2 at 1/3 HP
	1075	1075	1075	1075
<b>Indoor Fan—Type</b>				
No. Used/Diameter in. [mm]	FC Centrifugal	FC Centrifugal	FC Centrifugal	FC Centrifugal
Drive Type/No. Speeds	1/15x15 [381x381]	1/15x15 [381x381]	1/15x15 [381x381]	1/15x15 [381x381]
No. Motors	Belt/Variable	Belt/Variable	Belt/Variable	Belt/Variable
Motor HP	1	1	1	1
Motor RPM	2	2	3	3
Motor Frame Size	1725	1725	1725	1725
	56	56	56	56
<b>Filter—Type</b>				
Furnished	Disposable	Disposable	Disposable	Disposable
(NO.) Size Recommended in. [mm x mm x mm]	Yes	Yes	Yes	Yes
	(6)2x18x18 [51x457x457]	(6)2x18x18 [51x457x457]	(6)2x18x18 [51x457x457]	(6)2x18x18 [51x457x457]
<b>Refrigerant Charge Oz. (Sys. 1/Sys. 2) [g]</b>				
	105.6/105.6 [2994/2994]	105.6/105.6 [2994/2994]	105.6/105.6 [2994/2994]	105.6/105.6 [2994/2994]
<b>Weights</b>				
Net Weights lbs. [kg]	1056 [479]	1092 [495]	1064 [483]	1100 [499]
Ship Weights lbs. [kg]	1093 [496]	1129 [512]	1101 [499]	1137 [516]

### NOTES:

- Cooling Performance is rated at 95° F ambient, 80° F entering dry bulb, 67° F entering wet bulb. Gross capacity does not include the effect of fan motor heat. AHRI capacity is net and includes the effect of fan motor heat. Units are suitable for operation to 20% of nominal cfm. Units are certified in accordance with the Unitary Air Conditioner Equipment certification program, which is based on AHRI Standard 340/360.
- EER and/or SEER are rated at AHRI conditions and in accordance with DOE test procedures.
- IEER is rated in accordance with AHRI Standard 340/360. Units are rated at 80° F ambient, 80° F entering dry bulb, and 67° F entering wet bulb at ARI rated cfm.
- Heating Performance limit settings and rating data were established and approved under laboratory test conditions using American National Standard Institute standards. Ratings shown are for elevations up to 2000 feet. For elevations above 2000 feet, ratings should be reduced at the rate of 4% for each 1000 feet above sea level.
- Outdoor Sound Rating shown is tested in accordance with AHRI Standard 270.

# GENERAL DATA - RKRL MODELS

## NOM. SIZES 7.5-10 TON [26.4 - 35.2 kW]

Model RKRL-Series	C090YL22E	C090YM22E	C090YN22E	C120CL15E
<b>Cooling Performance<sup>1</sup></b>				<b>CONTINUED</b> →
Gross Cooling Capacity Btu [kW]	95,000 [27.83]	95,000 [27.83]	95,000 [27.83]	124,000 [36.33]
EER/SEER <sup>2</sup>	13/NA	13/NA	13/NA	12.5/NA
Nominal CFM/AHRI Rated CFM [L/s]	3000/2600 [1416/1227]	3000/2600 [1416/1227]	3000/2600 [1416/1227]	4000/3575 [1888/1687]
AHRI Net Cooling Capacity Btu [kW]	92,000 [26.96]	92,000 [26.96]	92,000 [26.96]	120,000 [35.16]
Net Sensible Capacity Btu [kW]	66,200 [19.4]	66,200 [19.4]	66,200 [19.4]	87,600 [25.67]
Net Latent Capacity Btu [kW]	25,800 [7.56]	25,800 [7.56]	25,800 [7.56]	32,400 [9.49]
IEER <sup>3</sup>	14	14	14	13.8
Net System Power kW	7.04	7.04	7.04	7.04
<b>Heating Performance (Gas)<sup>4</sup></b>				
Heating Input Btu [kW] (1st Stage / 2nd Stage)	112,500/225,000 [32.96/65.92]	112,500/225,000 [32.96/65.92]	112,500/225,000 [32.96/65.92]	75,000/150,000 [21.97/43.95]
Heating Output Btu [kW] (1st Stage / 2nd Stage)	91,125/182,250 [26.7/53.4]	91,125/182,250 [26.7/53.4]	91,125/182,250 [26.7/53.4]	60,750/121,500 [17.8/35.6]
Temperature Rise Range °F [°C] (1st Stage / 2nd Stage)	40-70 [22.2-38.9] / 40-70 [22.2-38.9]	40-70 [22.2-38.9] / 40-70 [22.2-38.9]	40-70 [22.2-38.9] / 40-70 [22.2-38.9]	15-45 [8.3-25] / 15-45 [8.3-25]
Steady State Efficiency (%)	81	81	81	81
No. Burners	9	9	9	6
No. Stages	2	2	2	2
Gas Connection Pipe Size in. [mm]	0.75 [19]	0.75 [19]	0.75 [19]	0.5 [12.7]
<b>Compressor</b>				
No./Type	2/Scroll	2/Scroll	2/Scroll	2/Scroll
<b>Outdoor Sound Rating (dB)<sup>5</sup></b>	88	88	88	88
<b>Outdoor Coil—Fin Type</b>	Louvered	Louvered	Louvered	Louvered
Tube Type	MicroChannel	MicroChannel	MicroChannel	MicroChannel
Tube Size in. [mm] OD	1 [25.4]	1 [25.4]	1 [25.4]	1 [25.4]
Face Area sq. ft. [sq. m]	27 [2.51]	27 [2.51]	27 [2.51]	27 [2.51]
Rows / FPI [FPCm]	1 / 23 [9]	1 / 22 [9]	1 / 23 [9]	1 / 23 [9]
<b>Indoor Coil—Fin Type</b>	Louvered	Louvered	Louvered	Louvered
Tube Type	Rifled	Rifled	Rifled	Rifled
Tube Size in. [mm]	0.375 [9.5]	0.375 [9.5]	0.375 [9.5]	0.375 [9.5]
Face Area sq. ft. [sq. m]	13.5 [1.25]	13.5 [1.25]	13.5 [1.25]	15.75 [1.46]
Rows / FPI [FPCm]	3 / 15 [6]	3 / 15 [6]	3 / 15 [6]	4 / 15 [6]
Refrigerant Control	TX Valves	TX Valves	TX Valves	TX Valves
Drain Connection No./Size in. [mm]	1/1 [25.4]	1/1 [25.4]	1/1 [25.4]	1/1 [25.4]
<b>Outdoor Fan—Type</b>	Propeller	Propeller	Propeller	Propeller
No. Used/Diameter in. [mm]	2/24 [609.6]	2/24 [609.6]	2/24 [609.6]	2/24 [609.6]
Drive Type/No. Speeds	Direct/1	Direct/1	Direct/1	Direct/1
CFM [L/s]	8000 [3775]	8000 [3775]	8000 [3775]	8000 [3775]
No. Motors/HP	2 at 1/3 HP	2 at 1/3 HP	2 at 1/3 HP	2 at 1/3 HP
Motor RPM	1075	1075	1075	1075
<b>Indoor Fan—Type</b>	FC Centrifugal	FC Centrifugal	FC Centrifugal	FC Centrifugal
No. Used/Diameter in. [mm]	1/15x15 [381x381]	1/15x15 [381x381]	1/15x15 [381x381]	1/15x15 [381x381]
Drive Type/No. Speeds	Belt/Variable	Belt/Variable	Belt/Variable	Belt/Variable
No. Motors	1	1	1	1
Motor HP	2	2	3	2
Motor RPM	1725	1725	1725	1725
Motor Frame Size	56	56	56	56
<b>Filter—Type</b>	Disposable	Disposable	Disposable	Disposable
Furnished	Yes	Yes	Yes	Yes
(NO.) Size Recommended in. [mm x mm x mm]	(6)2x18x18 [51x457x457]	(6)2x18x18 [51x457x457]	(6)2x18x18 [51x457x457]	(3)2x18x18 [51x457x457] (3)2x18x24 [51x457x610]
<b>Refrigerant Charge Oz. (Sys. 1/Sys. 2) [g]</b>	105.6/105.6 [2994/2994]	105.6/105.6 [2994/2994]	105.6/105.6 [2994/2994]	153.6/156.8 [4355/4445]
<b>Weights</b>				
Net Weights lbs. [kg]	1092 [495]	1092 [495]	1100 [499]	1205 [547]
Ship Weights lbs. [kg]	1129 [512]	1129 [512]	1137 [516]	1242 [563]

- NOTES:**
- Cooling Performance is rated at 95° F ambient, 80° F entering dry bulb, 67° F entering wet bulb. Gross capacity does not include the effect of fan motor heat. AHRI capacity is net and includes the effect of fan motor heat. Units are suitable for operation to 20% of nominal cfm. Units are certified in accordance with the Unitary Air Conditioner Equipment certification program, which is based on AHRI Standard 340/360.
  - EER and/or SEER are rated at AHRI conditions and in accordance with DOE test procedures.
  - IEER is rated in accordance with AHRI Standard 340/360. Units are rated at 80° F ambient, 80° F entering dry bulb, and 67° F entering wet bulb at ARI rated cfm.
  - Heating Performance limit settings and rating data were established and approved under laboratory test conditions using American National Standard Institute standards. Ratings shown are for elevations up to 2000 feet. For elevations above 2000 feet, ratings should be reduced at the rate of 4% for each 1000 feet above sea level.
  - Outdoor Sound Rating shown is tested in accordance with AHRI Standard 270.

# GENERAL DATA - RKRL MODELS

## NOM. SIZES 7.5-10 TON [26.4 - 35.2 kW]

Model RKRL-Series	C120CL22E	C120CM15E	C120CM22E	C120DL15E
<b>Cooling Performance<sup>1</sup></b>				<b>CONTINUED</b> →
Gross Cooling Capacity Btu [kW]	124,000 [36.33]	124,000 [36.33]	124,000 [36.33]	124,000 [36.33]
EER/SEER <sup>2</sup>	12.5/NA	12.5/NA	12.5/NA	12.5/NA
Nominal CFM/AHRI Rated CFM [L/s]	4000/3575 [1888/1687]	4000/3575 [1888/1687]	4000/3575 [1888/1687]	4000/3575 [1888/1687]
AHRI Net Cooling Capacity Btu [kW]	120,000 [35.16]	120,000 [35.16]	120,000 [35.16]	120,000 [35.16]
Net Sensible Capacity Btu [kW]	87,600 [25.67]	87,600 [25.67]	87,600 [25.67]	87,600 [25.67]
Net Latent Capacity Btu [kW]	32,400 [9.49]	32,400 [9.49]	32,400 [9.49]	32,400 [9.49]
IEER <sup>3</sup>	13.8	13.8	13.8	13.8
Net System Power kW	9.62	9.62	9.62	9.62
<b>Heating Performance (Gas)<sup>4</sup></b>				
Heating Input Btu [kW] (1st Stage / 2nd Stage)	112,500/225,000 [32.96/65.92]	75,000/150,000 [21.97/43.95]	112,500/225,000 [32.96/65.92]	75,000/150,000 [21.97/43.95]
Heating Output Btu [kW] (1st Stage / 2nd Stage)	91,125/182,250 [26.7/53.4]	60,750/121,500 [17.8/35.6]	91,125/182,250 [26.7/53.4]	60,750/121,500 [17.8/35.6]
Temperature Rise Range °F [°C] (1st Stage / 2nd Stage)	25-55 [13.9-30.6] / 25-55 [13.9-30.6]	15-45 [8.3-25] / 15-45 [8.3-25]	25-55 [13.9-30.6] / 25-55 [13.9-30.6]	15-45 [8.3-25] / 15-45 [8.3-25]
Steady State Efficiency (%)	81	81	81	81
No. Burners	9	6	9	6
No. Stages	2	2	2	2
Gas Connection Pipe Size in. [mm]	0.75 [19]	0.5 [12.7]	0.75 [19]	0.5 [12.7]
<b>Compressor</b>				
No./Type	2/Scroll	2/Scroll	2/Scroll	2/Scroll
<b>Outdoor Sound Rating (dB)<sup>5</sup></b>	88	88	88	88
<b>Outdoor Coil—Fin Type</b>	Louvered	Louvered	Louvered	Louvered
Tube Type	MicroChannel	MicroChannel	MicroChannel	MicroChannel
Tube Size in. [mm] OD	1 [25.4]	1 [25.4]	1 [25.4]	1 [25.4]
Face Area sq. ft. [sq. m]	27 [2.51]	27 [2.51]	27 [2.51]	27 [2.51]
Rows / FPI [FPcm]	2 / 23 [9]	2 / 23 [9]	2 / 23 [9]	2 / 23 [9]
<b>Indoor Coil—Fin Type</b>	Louvered	Louvered	Louvered	Louvered
Tube Type	Rifled	Rifled	Rifled	Rifled
Tube Size in. [mm]	0.375 [9.5]	0.375 [9.5]	0.375 [9.5]	0.375 [9.5]
Face Area sq. ft. [sq. m]	15.75 [1.46]	15.75 [1.46]	15.75 [1.46]	15.75 [1.46]
Rows / FPI [FPcm]	4 / 15 [6]	4 / 15 [6]	4 / 15 [6]	4 / 15 [6]
Refrigerant Control	TX Valves	TX Valves	TX Valves	TX Valves
Drain Connection No./Size in. [mm]	1/1 [25.4]	1/1 [25.4]	1/1 [25.4]	1/1 [25.4]
<b>Outdoor Fan—Type</b>	Propeller	Propeller	Propeller	Propeller
No. Used/Diameter in. [mm]	2/24 [609.6]	2/24 [609.6]	2/24 [609.6]	2/24 [609.6]
Drive Type/No. Speeds	Direct/1	Direct/1	Direct/1	Direct/1
CFM [L/s]	8000 [3775]	8000 [3775]	8000 [3775]	8000 [3775]
No. Motors/HP	2 at 1/3 HP	2 at 1/3 HP	2 at 1/3 HP	2 at 1/3 HP
Motor RPM	1075	1075	1075	1075
<b>Indoor Fan—Type</b>	FC Centrifugal	FC Centrifugal	FC Centrifugal	FC Centrifugal
No. Used/Diameter in. [mm]	1/15x15 [381x381]	1/15x15 [381x381]	1/15x15 [381x381]	1/15x15 [381x381]
Drive Type/No. Speeds	Belt/Variable	Belt/Variable	Belt/Variable	Belt/Variable
No. Motors	1	1	1	1
Motor HP	2	3	3	2
Motor RPM	1725	1725	1725	1725
Motor Frame Size	56	56	56	56
<b>Filter—Type</b>	Disposable	Disposable	Disposable	Disposable
Furnished	Yes	Yes	Yes	Yes
(NO.) Size Recommended in. [mm x mm x mm]	(6)2x18x18 [51x457x457]	(3)2x18x18 [51x457x457] (3)2x18x24 [51x457x610]	(3)2x18x18 [51x457x457] (3)2x18x24 [51x457x610]	(3)2x18x18 [51x457x457] (3)2x18x24 [51x457x610]
<b>Refrigerant Charge Oz. (Sys. 1/Sys. 2) [g]</b>	153.6/156.8 [4355/4445]	153.6/156.8 [4355/4445]	153.6/156.8 [4355/4445]	153.6/156.8 [4355/4445]
<b>Weights</b>				
Net Weights lbs. [kg]	1241 [563]	1213 [550]	1249 [567]	1205 [547]
Ship Weights lbs. [kg]	1278 [580]	1250 [567]	1286 [583]	1242 [563]

### NOTES:

- Cooling Performance is rated at 95° F ambient, 80° F entering dry bulb, 67° F entering wet bulb. Gross capacity does not include the effect of fan motor heat. AHRI capacity is net and includes the effect of fan motor heat. Units are suitable for operation to 20% of nominal cfm. Units are certified in accordance with the Unitary Air Conditioner Equipment certification program, which is based on AHRI Standard 340/360.
- EER and/or SEER are rated at AHRI conditions and in accordance with DOE test procedures.
- IEER is rated in accordance with AHRI Standard 340/360. Units are rated at 80° F ambient, 80° F entering dry bulb, and 67° F entering wet bulb at ARI rated cfm.
- Heating Performance limit settings and rating data were established and approved under laboratory test conditions using American National Standard Institute standards. Ratings shown are for elevations up to 2000 feet. For elevations above 2000 feet, ratings should be reduced at the rate of 4% for each 1000 feet above sea level.
- Outdoor Sound Rating shown is tested in accordance with AHRI Standard 270.

# GENERAL DATA - RKRL MODELS

## NOM. SIZES 7.5-10 TON [26.4 - 35.2 kW]

Model RKRL-Series	C120DL22E	C120DM15E	C120DM22E	C120YL22E
<b>Cooling Performance<sup>1</sup></b>				<b>CONTINUED</b> →
Gross Cooling Capacity Btu [kW]	124,000 [36.33]	124,000 [36.33]	124,000 [36.33]	124,000 [36.33]
EER/SEER <sup>2</sup>	12.5/NA	12.5/NA	12.5/NA	12.5/NA
Nominal CFM/AHRI Rated CFM [L/s]	4000/3575 [1888/1687]	4000/3575 [1888/1687]	4000/3575 [1888/1687]	4000/3575 [1888/1687]
AHRI Net Cooling Capacity Btu [kW]	120,000 [35.16]	120,000 [35.16]	120,000 [35.16]	120,000 [35.16]
Net Sensible Capacity Btu [kW]	87,600 [25.67]	87,600 [25.67]	87,600 [25.67]	87,600 [25.67]
Net Latent Capacity Btu [kW]	32,400 [9.49]	32,400 [9.49]	32,400 [9.49]	32,400 [9.49]
IEER <sup>3</sup>	13.8	13.8	13.8	13.8
Net System Power kW	9.62	9.62	9.62	9.62
<b>Heating Performance (Gas)<sup>4</sup></b>				
Heating Input Btu [kW] (1st Stage / 2nd Stage)	112,500/225,000 [32.96/65.92]	75,000/150,000 [21.97/43.95]	112,500/225,000 [32.96/65.92]	112,500/225,000 [32.96/65.92]
Heating Output Btu [kW] (1st Stage / 2nd Stage)	91,125/182,250 [26.7/53.4]	60,750/121,500 [17.8/35.6]	91,125/182,250 [26.7/53.4]	91,125/182,250 [26.7/53.4]
Temperature Rise Range °F [°C] (1st Stage / 2nd Stage)	25-55 [13.9-30.6] / 25-55 [13.9-30.6]	15-45 [8.3-25] / 15-45 [8.3-25]	25-55 [13.9-30.6] / 25-55 [13.9-30.6]	25-55 [13.9-30.6] / 25-55 [13.9-30.6]
Steady State Efficiency (%)	81	81	81	81
No. Burners	9	6	9	9
No. Stages	2	2	2	2
Gas Connection Pipe Size in. [mm]	0.75 [19]	0.5 [12.7]	0.75 [19]	0.75 [19]
<b>Compressor</b>				
No./Type	2/Scroll	2/Scroll	2/Scroll	2/Scroll
<b>Outdoor Sound Rating (dB)<sup>5</sup></b>	88	88	88	88
<b>Outdoor Coil—Fin Type</b>	Louvered	Louvered	Louvered	Louvered
Tube Type	MicroChannel	MicroChannel	MicroChannel	MicroChannel
Tube Size in. [mm] OD	1 [25.4]	1 [25.4]	1 [25.4]	1 [25.4]
Face Area sq. ft. [sq. m]	27 [2.51]	27 [2.51]	27 [2.51]	27 [2.51]
Rows / FPI [FPCm]	2 / 23 [9]	2 / 23 [9]	2 / 23 [9]	2 / 23 [9]
<b>Indoor Coil—Fin Type</b>	Louvered	Louvered	Louvered	Louvered
Tube Type	Rifled	Rifled	Rifled	Rifled
Tube Size in. [mm]	0.375 [9.5]	0.375 [9.5]	0.375 [9.5]	0.375 [9.5]
Face Area sq. ft. [sq. m]	15.75 [1.46]	15.75 [1.46]	15.75 [1.46]	15.75 [1.46]
Rows / FPI [FPCm]	4 / 15 [6]	4 / 15 [6]	4 / 15 [6]	4 / 15 [6]
Refrigerant Control	TX Valves	TX Valves	TX Valves	TX Valves
Drain Connection No./Size in. [mm]	1/1 [25.4]	1/1 [25.4]	1/1 [25.4]	1/1 [25.4]
<b>Outdoor Fan—Type</b>	Propeller	Propeller	Propeller	Propeller
No. Used/Diameter in. [mm]	2/24 [609.6]	2/24 [609.6]	2/24 [609.6]	2/24 [609.6]
Drive Type/No. Speeds	Direct/1	Direct/1	Direct/1	Direct/1
CFM [L/s]	8000 [3775]	8000 [3775]	8000 [3775]	8000 [3775]
No. Motors/HP	2 at 1/3 HP	2 at 1/3 HP	2 at 1/3 HP	2 at 1/3 HP
Motor RPM	1075	1075	1075	1075
<b>Indoor Fan—Type</b>	FC Centrifugal	FC Centrifugal	FC Centrifugal	FC Centrifugal
No. Used/Diameter in. [mm]	1/15x15 [381x381]	1/15x15 [381x381]	1/15x15 [381x381]	1/15x15 [381x381]
Drive Type/No. Speeds	Belt/Variable	Belt/Variable	Belt/Variable	Belt/Variable
No. Motors	1	1	1	1
Motor HP	2	3	3	2
Motor RPM	1725	1725	1725	1725
Motor Frame Size	56	56	56	56
<b>Filter—Type</b>	Disposable	Disposable	Disposable	Disposable
Furnished	Yes	Yes	Yes	Yes
(NO.) Size Recommended in. [mm x mm x mm]	(3)2x18x18 [51x457x457] (3)2x18x24 [51x457x610]	(3)2x18x18 [51x457x457] (3)2x18x24 [51x457x610]	(3)2x18x18 [51x457x457] (3)2x18x24 [51x457x610]	(3)2x18x18 [51x457x457] (3)2x18x24 [51x457x610]
<b>Refrigerant Charge Oz. (Sys. 1/Sys. 2) [g]</b>	153.6/156.8 [4355/4445]	153.6/156.8 [4355/4445]	153.6/156.8 [4355/4445]	153.6/156.8 [4355/4445]
<b>Weights</b>				
Net Weights lbs. [kg]	1241 [563]	1213 [550]	1249 [567]	1241 [563]
Ship Weights lbs. [kg]	1278 [580]	1250 [567]	1286 [583]	1278 [580]

- NOTES:**
- Cooling Performance is rated at 95° F ambient, 80° F entering dry bulb, 67° F entering wet bulb. Gross capacity does not include the effect of fan motor heat. AHRI capacity is net and includes the effect of fan motor heat. Units are suitable for operation to 20% of nominal cfm. Units are certified in accordance with the Unitary Air Conditioner Equipment certification program, which is based on AHRI Standard 340/360.
  - EER and/or SEER are rated at AHRI conditions and in accordance with DOE test procedures.
  - IEER is rated in accordance with AHRI Standard 340/360. Units are rated at 80° F ambient, 80° F entering dry bulb, and 67° F entering wet bulb at ARI rated cfm.
  - Heating Performance limit settings and rating data were established and approved under laboratory test conditions using American National Standard Institute standards. Ratings shown are for elevations up to 2000 feet. For elevations above 2000 feet, ratings should be reduced at the rate of 4% for each 1000 feet above sea level.
  - Outdoor Sound Rating shown is tested in accordance with AHRI Standard 270.

# GENERAL DATA - RKRL MODELS

## NOM. SIZES 7.5-10 TON [26.4 - 35.2 kW]

Model RKRL-Series	C120YM22E
<b>Cooling Performance<sup>1</sup></b>	
Gross Cooling Capacity Btu [kW]	124,000 [36.33]
EER/SEER <sup>2</sup>	12.5/NA
Nominal CFM/AHRI Rated CFM [L/s]	4000/3575 [1888/1687]
AHRI Net Cooling Capacity Btu [kW]	120,000 [35.16]
Net Sensible Capacity Btu [kW]	87,600 [25.67]
Net Latent Capacity Btu [kW]	32,400 [9.49]
IEER <sup>3</sup>	13.8
Net System Power kW	9.62
<b>Heating Performance (Gas)<sup>4</sup></b>	
Heating Input Btu [kW] (1st Stage / 2nd Stage)	112,500/225,000 [32.96/65.92]
Heating Output Btu [kW] (1st Stage / 2nd Stage)	91,125/182,250 [26.7/53.4]
Temperature Rise Range °F [°C] (1st Stage / 2nd Stage)	25-55 [13.9-30.6] / 25-55 [13.9-30.6]
Steady State Efficiency (%)	81
No. Burners	9
No. Stages	2
Gas Connection Pipe Size in. [mm]	0.75 [19]
<b>Compressor</b>	
No./Type	2/Scroll
<b>Outdoor Sound Rating (dB)<sup>5</sup></b>	
	88
<b>Outdoor Coil—Fin Type</b>	
Tube Type	Louvered
Tube Size in. [mm] OD	MicroChannel
Face Area sq. ft. [sq. m]	1 [25.24]
Rows / FPI [FPcm]	27 [2.51]
	2 / 23 [9]
<b>Indoor Coil—Fin Type</b>	
Tube Type	Louvered
Tube Size in. [mm]	Rifled
Face Area sq. ft. [sq. m]	0.375 [9.5]
Rows / FPI [FPcm]	15.75 [1.46]
Refrigerant Control	4 / 15 [6]
Drain Connection No./Size in. [mm]	TX Valves
	1/1 [25.4]
<b>Outdoor Fan—Type</b>	
No. Used/Diameter in. [mm]	Propeller
Drive Type/No. Speeds	2/24 [609.6]
CFM [L/s]	Direct/1
No. Motors/HP	8000 [3775]
Motor RPM	2 at 1/3 HP
	1075
<b>Indoor Fan—Type</b>	
No. Used/Diameter in. [mm]	FC Centrifugal
Drive Type/No. Speeds	1/15x15 [381x381]
No. Motors	Belt/Variable
Motor HP	1
Motor RPM	3
Motor Frame Size	1725
	56
<b>Filter—Type</b>	
Furnished	Disposable
(NO.) Size Recommended in. [mm x mm x mm]	Yes
	(3)2x18x18 [51x457x457]
	(3)2x18x24 [51x457x610]
<b>Refrigerant Charge Oz. (Sys. 1/Sys. 2) [g]</b>	
	153.6/156.8 [4355/4445]
<b>Weights</b>	
Net Weights lbs. [kg]	1249 [567]
Ship Weights lbs. [kg]	1286 [583]

### NOTES:

- Cooling Performance is rated at 95° F ambient, 80° F entering dry bulb, 67° F entering wet bulb. Gross capacity does not include the effect of fan motor heat. AHRI capacity is net and includes the effect of fan motor heat. Units are suitable for operation to 20% of nominal cfm. Units are certified in accordance with the Unitary Air Conditioner Equipment certification program, which is based on AHRI Standard 340/360.
- EER and/or SEER are rated at AHRI conditions and in accordance with DOE test procedures.
- IEER is rated in accordance with AHRI Standard 340/360. Units are rated at 80° F ambient, 80° F entering dry bulb, and 67° F entering wet bulb at ARI rated cfm.
- Heating Performance limit settings and rating data were established and approved under laboratory test conditions using American National Standard Institute standards. Ratings shown are for elevations up to 2000 feet. For elevations above 2000 feet, ratings should be reduced at the rate of 4% for each 1000 feet above sea level.
- Outdoor Sound Rating shown is tested in accordance with AHRI Standard 270.

# ELECTRICAL DATA - RKRL MODELS

ELECTRICAL DATA - RKRL SERIES										
		C090CL	C090CM	C090CN	C090DL	C090DM	C090DN	C090YL	C090YM	C090YN
Unit Information	Unit Operating Voltage Range	187-253	187-253	187-253	414-506	414-506	414-506	518-632	518-632	518-632
	Volts	208/230	208/230	208/230	460	460	460	575	575	575
	Minimum Circuit Ampacity	44/44	44/44	49/49	21	21	24	16	16	21
	Minimum Overcurrent Protection Device Size	50/50	50/50	60/60	25	25	30	20	20	25
	Maximum Overcurrent Protection Device Size	50/50	50/50	60/60	25	25	30	20	20	25
Compressor Motor	No.	2	2	2	2	2	2	2	2	2
	Volts	200/240	200/240	200/240	480	480	480	600	600	600
	Phase	3	3	3	3	3	3	3	3	3
	RPM	3450	3450	3450	3450	3450	3450	3450	3450	3450
	HP, Compressor 1	3 1/4	3 1/4	3 1/4	3 1/4	3 1/4	3 1/4	3 1/4	3 1/4	3 1/4
	Amps (RLA), Comp. 1	13.6/13.6	13.6/13.6	13.6/13.6	6.1	6.1	6.1	4.2	4.2	4.2
	Amps (LRA), Comp. 1	83.1/83.1	83.1/83.1	83.1/83.1	41	41	41	33	33	33
	HP, Compressor 2	3 1/4	3 1/4	3 1/4	3 1/4	3 1/4	3 1/4	3 1/4	3 1/4	3 1/4
	Amps (RLA), Comp. 2	13.6/13.6	13.6/13.6	13.6/13.6	6.1	6.1	6.1	4.2	4.2	4.2
	Amps (LRA), Comp. 2	83.1/83.1	83.1/83.1	83.1/83.1	41	41	41	33	33	33
Condenser Motor	No.	2	2	2	2	2	2	2	2	2
	Volts	208/230	208/230	208/230	460	460	460	575	575	575
	Phase	1	1	1	1	1	1	1	1	1
	HP	1/3	1/3	1/3	1/3	1/3	1/3	1/3	1/3	1/3
	Amps (FLA, each)	2.4/2.4	2.4/2.4	2.4/2.4	1.4	1.4	1.4	1	1	1
	Amps (LRA, each)	4.7/4.7	4.7/4.7	4.7/4.7	2.4	2.4	2.4	1.5	1.5	1.5
Evaporator Fan	No.	1	1	1	1	1	1	1	1	1
	Volts	208/230	208/230	208/230	460	460	460	575	575	575
	Phase	3	3	3	3	3	3	3	3	3
	HP	2	2	3	2	2	3	2	2	3
	Amps (FLA, each)	8/8	8/8	13/13	4	4	7	4	4	8
	Amps (LRA, each)	56/56	74.5/74.5	74.5/74.5	28	28	38.1	19	19	20

# ELECTRICAL DATA - RKRL MODELS

ELECTRICAL DATA - RKRL SERIES										
		C120CL	C120CM	C120DL	C120DM	C120YL	C120YM			
Unit Information	Unit Operating Voltage Range	187-253	187-253	414-506	414-506	518-632	518-632			
	Volts	208/230	208/230	460	460	575	575			
	Minimum Circuit Ampacity	49/49	54/54	23	26	18	23			
	Minimum Overcurrent Protection Device Size	60/60	60/60	25	30	20	30			
	Maximum Overcurrent Protection Device Size	60/60	60/60	25	30	20	30			
Compressor Motor	No.	2	2	2	2	2	2			
	Volts	200/240	200/240	480	480	575	575			
	Phase	3	3	3	3	3	3			
	RPM	3450	3450	3450	3450	3450	3450			
	HP, Compressor 1	4 1/4	4 1/4	4 1/4	4 1/4	4 1/4	4 1/4			
	Amps (RLA), Comp. 1	15.9/15.9	15.9/15.9	7.1	7.1	5.1	5.1			
	Amps (LRA), Comp. 1	110/110	110/110	52	52	39.5	39.5			
	HP, Compressor 2	4 1/4	4 1/4	4 1/4	4 1/4	4 1/4	4 1/4			
	Amps (RLA), Comp. 2	15.9/15.9	15.9/15.9	7.1	7.1	5.1	5.1			
	Amps (LRA), Comp. 2	110/11	110/1100	52	52	39.5	39.5			
Condenser Motor	No.	2	2	2	2	2	2			
	Volts	208/230	208/230	460	460	575	575			
	Phase	1	1	1	1	1	1			
	HP	1/3	1/3	1/3	1/3	1/3	1/3			
	Amps (FLA, each)	2.4	2.4	1.4	1.4	1	1			
	Amps (LRA, each)	4.7/4.7	4.7/4.7	2.4	2.4	1.5	1.5			
Evaporator Fan	No.	1	1	1	1	1	1			
	Volts	208/230	208/230	460	460	575	575			
	Phase	3	3	3	3	3	3			
	HP	2	3	2	3	2	3			
	Amps (FLA, each)	8/8	13/13	4	7	4	8			
	Amps (LRA, each)	56/56	74.5/74.5	28	38.1	19	20			

## II. INSTALLATION

### A. GENERAL

1. **INSTALLATION** — Install this unit in accordance with The American National Standard Z223.1-latest edition booklet entitled “National Fuel Gas Code,” and the requirements or codes of the local utility or other authority having jurisdiction.

Additional helpful publications available from the “National Fire Protection Association” are: NFPA-90A - Installation of Air Conditioning and Ventilating Systems 1985 or latest edition. NFPA-90B - Warm Air Heating and Air Conditioning Systems 1984.

These publications are available from:

National Fire Protection  
Association, Inc.  
Batterymarch Park  
Quincy, MA 02269

2. **PRE-INSTALLATION CHECKPOINTS** — Before attempting any installation, carefully consider the following points:

Structural strength of supporting members

(Rooftop Installation)

Clearances and provision for servicing

Power supply and wiring

Gas supply and piping

Air duct connections and sizing

Drain facilities and connections

Location for minimum noise and vibration - away from bedroom windows

### LOCATION CONSIDERATIONS

The metal parts of this unit may be subject to rust or deterioration in adverse environmental conditions. This oxidation could shorten the equipment’s useful life. Salt spray, fog or mist in seacoast areas, sulphur or chlorine from lawn watering systems, and various chemical contaminants from industries such as paper mills and petroleum refineries are especially corrosive.

**If the unit is to be installed in an area where contaminants are likely to be a problem, give special attention to the equipment location and exposure.**

1. Avoid having lawn sprinkler heads spray directly on the unit cabinet.
2. In coastal areas locate the unit on the side of the building away from the waterfront.
3. Shielding by a fence or shrubs may give some protection.

#### **▲ WARNING**

**DISCONNECT ALL POWER TO UNIT BEFORE STARTING MAINTENANCE. FAILURE TO DO SO CAN CAUSE ELECTRICAL SHOCK RESULTING IN PERSONAL INJURY OR DEATH. REGULAR MAINTENANCE WILL REDUCE THE BUILDUP OF CONTAMINANTS AND HELP TO PROTECT THE UNIT’S FINISH.**

1. Frequent washing of the cabinet, fan blade and coil with fresh water will remove most of the salt or other contaminants that build up on the unit.
2. Regular cleaning and waxing of the cabinet with an automobile polish will provide some protection.

3. A liquid cleaner may be used several times a year to remove matter that will not wash off with water.

Several different types of protective coatings are offered in some areas. These coatings may provide some benefit, but the effectiveness of such coating materials cannot be verified by the equipment manufacturer.

**The best protection is frequent cleaning, maintenance and minimal exposure to contaminants.**

### B. OUTSIDE INSTALLATION

#### **▲ WARNING**

**THESE UNITS ARE DESIGNED CERTIFIED FOR OUTDOOR INSTALLATION ONLY. INSTALLATION INSIDE ANY PART OF A STRUCTURE CAN RESULT IN INADEQUATE UNIT PERFORMANCE AS WELL AS PROPERTY DAMAGE. INSTALLATION INSIDE CAN ALSO CAUSE RECIRCULATION OF FLUE PRODUCTS INTO THE CONDITIONED SPACE RESULTING IN PERSONAL INJURY OR DEATH.**

**FIGURE 7**

**OUTSIDE SLAB INSTALLATION. CLOSET DISTRIBUTION SYSTEM. SLAB FLOOR CONSTRUCTION.**

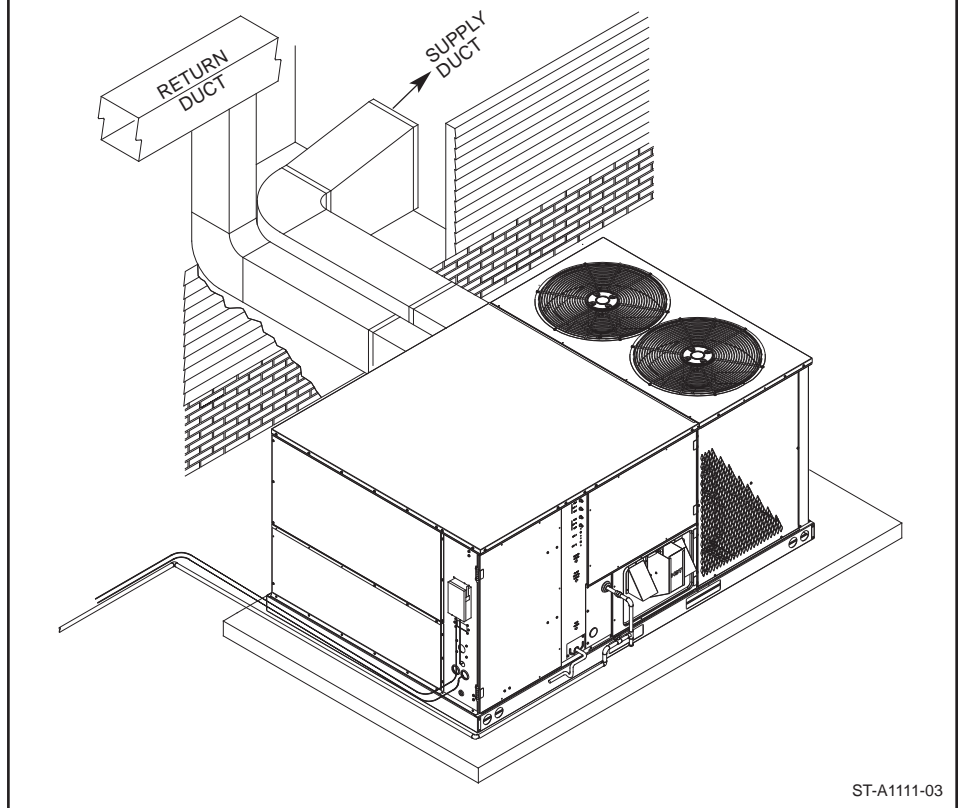

ST-A1111-03



(Typical outdoor slab installation is shown in Figure 7.)

1. Select a location where external water drainage cannot collect around unit.
2. Provide a level slab sufficiently high enough above grade to prevent surface water from entering the unit
3. Locate the unit to provide proper access for inspection and servicing as shown in Figure 9.
4. Locate unit where operating sounds will not disturb owner or neighbors.
5. Locate unit so roof runoff water does not pour directly on the unit. Provide gutter or other shielding at roof level. Do not locate unit in an area where excessive snow drifting may occur or accumulate.
6. Where snowfall is anticipated, the height of the unit above the ground level must be considered. Mount unit high enough to be above anticipated maximum area snowfall and to allow combustion air to enter the combustion air inlet.
7. Select an area which will keep the areas of the vent, air intake, and A/C condenser fins free and clear of obstructions such as weeds, shrubs, vines, snow, etc. Inform the user accordingly.

### C. ATTACHING EXHAUST AND COMBUSTION AIR INLET HOODS

**IMPORTANT: Do not operate this unit without the exhaust/combustion air inlet hood properly installed. This hood is shipped in a carton in the blower compartment inside the unit and must be attached when the unit is installed. See Figure 5.**

To attach exhaust/combustion air inlet hood:

1. Remove screws securing blower access panel and remove access panel. For location of blower access panel, see Figure 5.
2. Remove exhaust/combustion air inlet hood from the carton, located inside the blower compartment.
3. Attach blower access panel.
4. Attach the combustion air inlet/exhaust hood with screws. Reference Figure 5 for proper location. Screws are in carton with the hood.
5. Vent the unit using the flue exhaust hood, as supplied from the factory, without alteration or addition. Consult your local utility or other authority having jurisdiction for accepted venting techniques.

### D. COVER PANEL INSTALLATION/ CONVERSION PROCEDURE

DOWNFLOW TO HORIZONTAL

1. Remove the screws and covers from the outside of the supply and return sections. See Figure 2.
2. Install the covers over the bottom supply and return openings, painted side up, inserting the leading flange under the bracket provided. Place the back flange to top of the front bracket provided. See Figure 8.
3. Secure the return and supply cover to front bracket with one (1) screw.

### E. FILTER REPLACEMENT

This unit is provided with 6 - 18" X 18" X 2" disposable filters. When replacing filters, ensure they are inserted fully to the back to prevent bypass. See Figure 3.

Recommended supplier of this filter is Glassfloss Industries, Inc. or equivalent.

**FIGURE 8**  
COVER GASKET DETAIL FOR UNITS SHIPPED FOR DOWNFLOW APPLICATION BEING CONVERTED TO HORIZONTAL

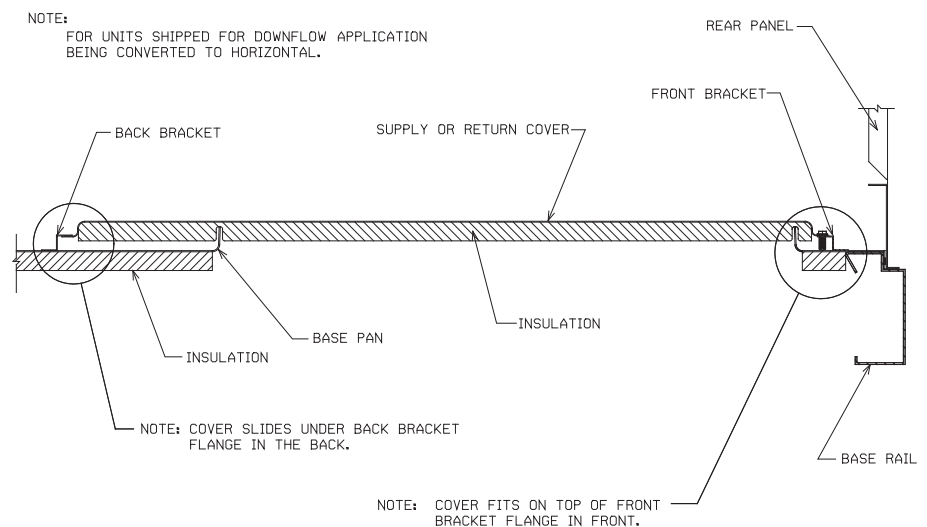

A074001

## E. CLEARANCES

The following minimum clearances must be observed for proper unit performance and serviceability. Reference Figure 9.

Recommended Clearance	Location
48"	A - Front
18"	B - Condenser Coil
18"	C - Duct Side
18"*	D - Evaporator End
60"	E - Above

\*Without Economizer. 48" With Economizer

**FIGURE 9  
CLEARANCES**

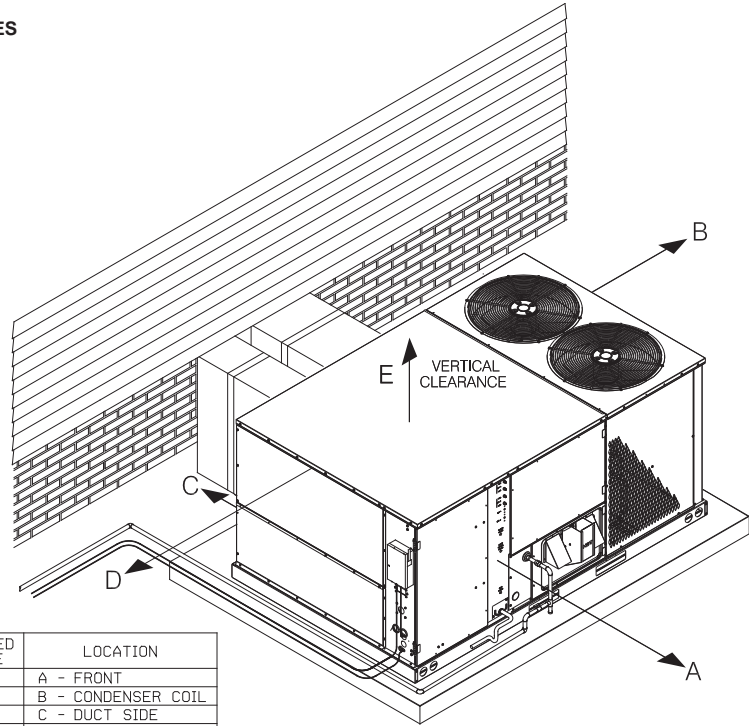

RECOMMENDED CLEARANCE	LOCATION
48"	A - FRONT
18"	B - CONDENSER COIL
18"	C - DUCT SIDE
18"	D - EVAPORATOR END
60"	E - ABOVE

\* WITHOUT ECONOMIZER/48" WITH ECONOMIZER

ST-A1111-03

**FIGURE 10A**

FLAT ROOFTOP INSTALLATION, ATTIC OR DROP CEILING DISTRIBUTING SYSTEM.  
MOUNTED ON ROOFCURB. CURB MUST BE LEVEL.

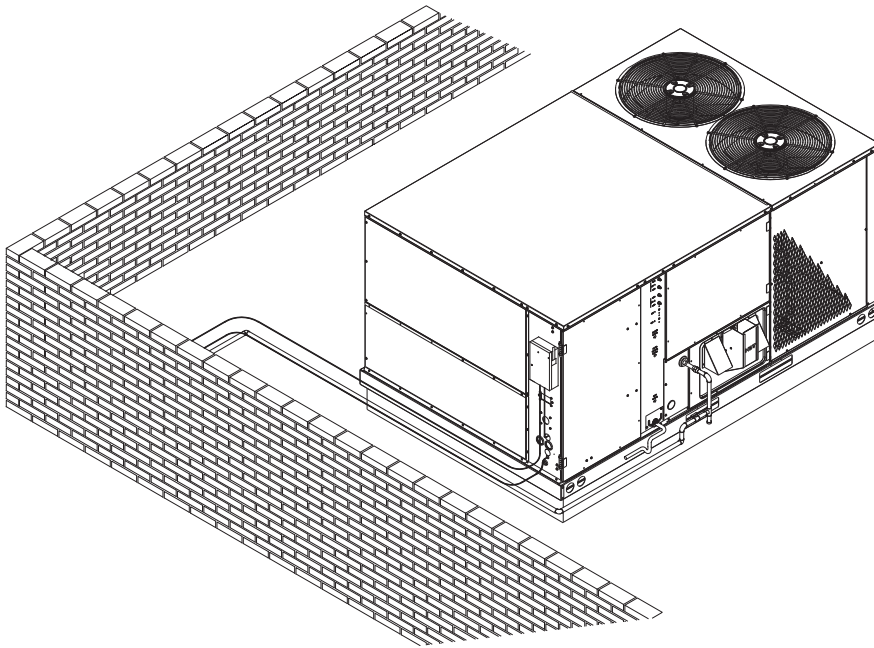

ST-A1111-03

**FIGURE 10B**

FLAT ROOFTOP INSTALLATION, ATTIC OR DROP CEILING DISTRIBUTING SYSTEM.  
MOUNTED ON ROOFCURB. CURB MUST BE LEVEL.

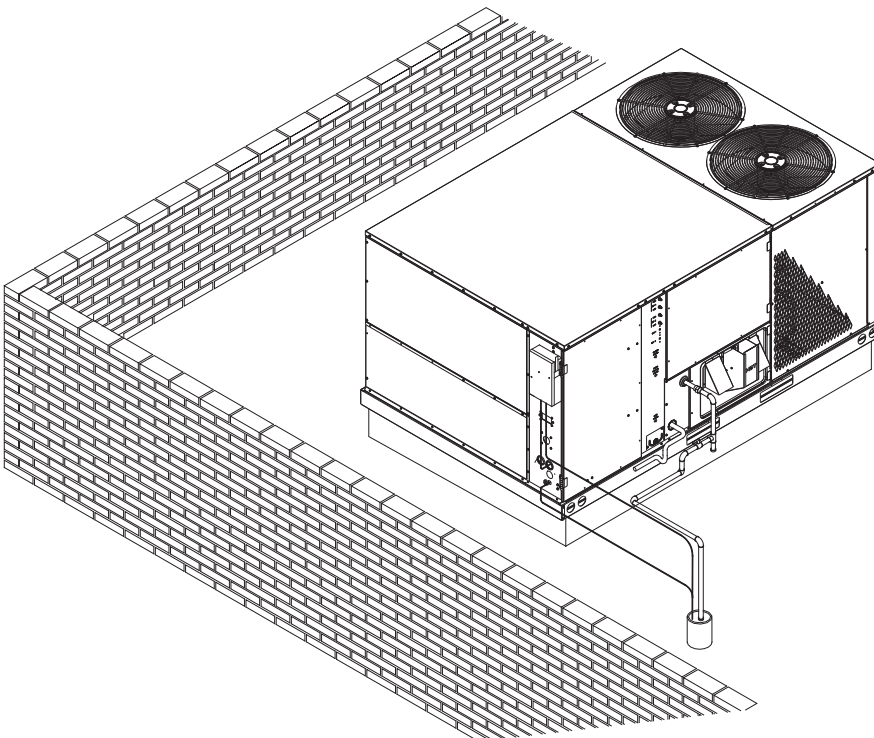

ST-A1111-03

## G. ROOFTOP INSTALLATION

1. Before locating the unit on the roof, make sure that the roof structure is adequate to support the weight involved. (See Electrical & Physical Tables in this manual.) **THIS IS VERY IMPORTANT AND THE INSTALLER'S RESPONSIBILITY.**
2. For rigging and roofcurb details, see Figures 11, 12 and 13.
3. The location of the unit on the roof should be such as to provide proper access for inspection and servicing.

**IMPORTANT:** If unit will not be put into service immediately, block off supply and return air openings to prevent excessive condensation.

## H. DUCTING

The installing contractor should fabricate ductwork in accordance with local codes. Use industry manuals as a guide when sizing and designing the duct system. Contact Air Conditioning Contractors of America, 1513 16th St. N.W., Washington, D.C. 20036.

### **▲ WARNING**

**DO NOT, UNDER ANY CIRCUMSTANCES, CONNECT RETURN DUCTWORK TO ANY OTHER HEAT PRODUCING DEVICE SUCH AS FIREPLACE INSERT, STOVE, ETC. UNAUTHORIZED USE OF SUCH DEVICES MAY RESULT IN FIRE, CARBON MONOXIDE POISONING, EXPLOSION, PERSONAL INJURY, PROPERTY DAMAGE OR DEATH.**

Place the unit as close to the conditioned space as possible allowing clearances as indicated. Run ducts as directly as possible to supply and return outlets. Use of non-flammable weatherproof flexible connectors on both supply and return connections at unit to reduce noise transmission is recommended.

On ductwork exposed to outside temperature and humidity, use a minimum of 2" of insulation and a vapor barrier. Distribution system in attic, furred space or crawl space should be insulated with at least 2" of insulation. Half-inch to 1" thick insulation is usually sufficient for ductwork inside the air conditioned space.

Provide balancing dampers for each branch duct in the supply system. Properly support ductwork from the structure.

**IMPORTANT:** In the event that the return air ducts must be run through an "unconfined" space containing other fuel burning equipment, it is imperative that the user/homeowner must be informed against future changes in construction which might change this to a "confined space." Also, caution the

user/homeowner against any future installation of additional equipment (such as power ventilators, clothes dryers, etc.), within the existing unconfined and/or confined space which might create a negative pressure within the vicinity of other solid, liquid, or gas fueled appliances.

## RETURN AIR

### ▲ WARNING

NEVER ALLOW PRODUCTS OF COMBUSTION OR THE FLUE PRODUCTS TO ENTER THE RETURN AIR DUCTWORK, OR THE CIRCULATING AIR SUPPLY. ALL RETURN DUCTWORK MUST BE ADEQUATELY SEALED AND SECURED TO THE FURNACE WITH SHEET METAL SCREWS, AND JOINTS

TAPED. ALL OTHER DUCT JOINTS MUST BE SECURED WITH APPROVED CONNECTIONS AND SEALED AIRTIGHT.

FAILURE TO PREVENT PRODUCTS OF COMBUSTION FROM BEING CIRCULATED INTO THE LIVING SPACE CAN CREATE POTENTIALLY HAZARDOUS CONDITIONS, INCLUDING CARBON MONOXIDE POISONING THAT COULD RESULT IN PERSONAL INJURY OR DEATH.

**FIGURE 11**  
LIFTING DETAIL

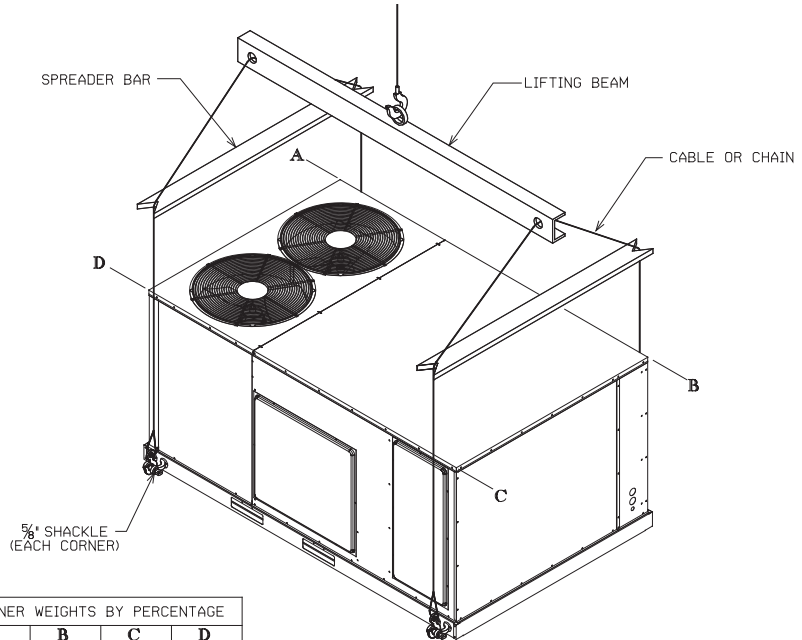

CORNER WEIGHTS BY PERCENTAGE			
A	B	C	D
33%	27%	17%	23%

I-744

**FIGURE 12**  
ROOFCURB

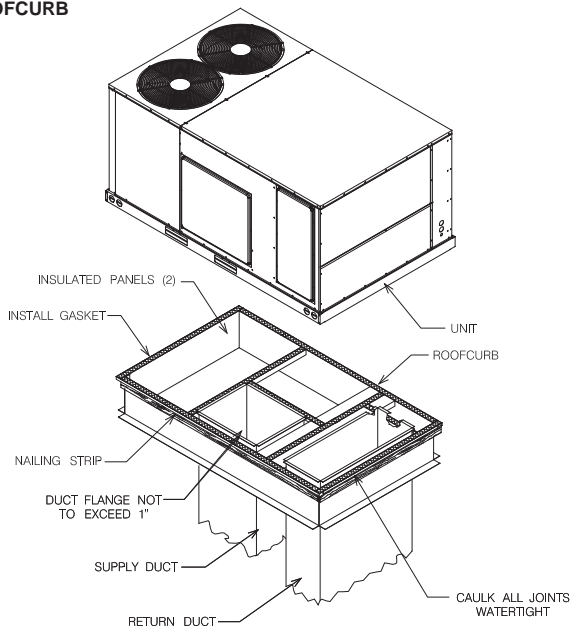

A074302

**FIGURE 13**  
ROOFCURB

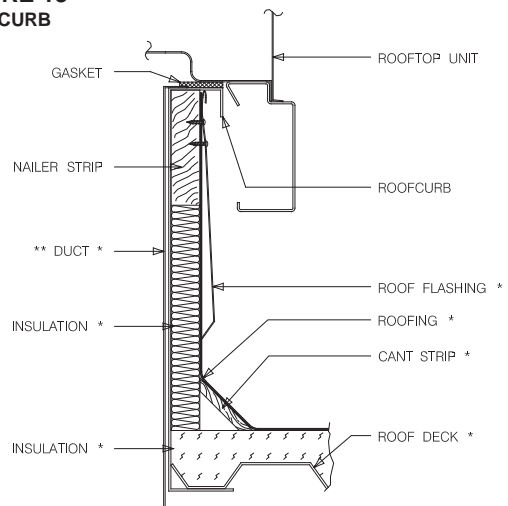

\* BY CONTRACTOR

\*\* FOR INSTALLATION OF DUCT AS SHOWN, USE RECOMMENDED DUCT SIZES FROM ROOFCURB INSTALLATION INSTRUCTIONS. FOR DUCT FLANGE ATTACHMENT TO UNIT, SEE UNIT INSTALLATION INSTRUCTIONS FOR RECOMMENDED DUCT SIZES.

A074302

# III. GAS SUPPLY, CONDENSATE DRAIN AND PIPING

## A. GAS CONNECTION

**IMPORTANT:** Connect this unit only to gas supplied by a commercial utility.

1. Install gas piping in accordance with local codes and regulations of the local utility company. In the absence of local codes, the installation must conform to the specifications of the National Fuel Gas Code, ANSI Z223.1 - latest edition.

NOTE: The use of flexible gas connectors is not permitted.

2. Connect the gas line to the gas valve supplied with unit. Routing can be through the gas pipe opening shown in Figures 7 or 10 or through the base as shown in Figure 17.
3. Size the gas line to the furnace adequate enough to prevent undue pressure drop and never less than 1/2".
4. Install a drip leg or sediment trap in the gas supply line as close to the unit as possible.
5. Install an outside ground joint union to connect the gas supply to the control assembly at the burner tray.
6. Gas valves have been factory installed. Install a manual gas valve where local codes specify a shut-off valve outside the unit casing. (See Figure 14.)
7. Make sure piping is tight. **A pipe compound resistant to the action of liquefied petroleum gases must be used at all threaded pipe connections.**

8. **IMPORTANT:** any additions, changes or conversions required for the furnace to satisfactorily meet the application should be made by a qualified installer, service agency or the gas supplier, using factory-specified or approved parts. In the commonwealth of Massachusetts, installation must be performed by a licensed plumber or gas fitter for appropriate fuel.

**IMPORTANT:** Disconnect the furnace and its individual shutoff valve from the gas supply piping during any pressure testing of that system at test pressures in excess of 1/2 pound per square inch gauge or isolate the system from the gas supply piping system by closing its individual manual shutoff valve during any pressure testing of this gas supply system at pressures equal to or less than 1/2 PSIG.

**TO CHECK FOR GAS LEAKS, USE A SOAP AND WATER SOLUTION OR OTHER APPROVED METHOD. DO NOT USE AN OPEN FLAME.**

### ⚠ WARNING

**DO NOT USE AN OPEN FLAME TO CHECK FOR LEAKS. THE USE OF AN OPEN FLAME CAN RESULT IN FIRE, EXPLOSION, PROPERTY DAMAGE, PERSONAL INJURY OR DEATH.**

**IMPORTANT:** Check the rating plate to make certain the appliance is equipped to burn the type of gas supplied. Care should be taken after installation of this equipment that the gas control valve not be subjected to high gas supply line pressure.

In making gas connections, avoid strains as they may cause noise and damage the controls. A backup wrench is required to be used on the valve to avoid damage.

**TABLE 10**  
GAS PIPE CAPACITY TABLE (CU. FT./HR.)

Nominal Iron Pipe Size, Inches	Equivalent Length of Pipe, Feet							
	10	20	30	40	50	60	70	80
1/2	132	92	73	63	56	50	46	43
3/4	278	190	152	130	115	105	96	90
1	520	350	285	245	215	195	180	170
1 1/4	1,050	730	590	500	440	400	370	350
1 1/2	1,600	1,100	890	760	670	610	560	530

**FIGURE 14**  
SUGGESTED GAS PIPING

### ROOF OR GROUND LEVEL INSTALLATION

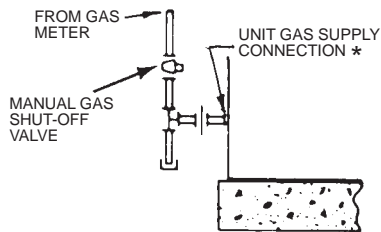

\*Factory supplied grommet must be utilized.

The capacities of gas pipe of different diameters and lengths in cu. ft. per hr. with pressure drop of 0.3 in. and specific gravity of 0.60 (natural gas) are shown in Table 10.

After determining the pipe length, select the pipe size which will provide the minimum cubic feet per hour required for the gas input rating of the furnace. By formula:

$$\text{Cu. Ft. Per Hr. Required} = \frac{\text{Gas Input of Furnace (BTU/HR)}}{\text{Heating Value of Gas (BTU/FT}^3\text{)}}$$

The gas input of the furnace is marked on the furnace rating plate. The heating value of the gas (BTU/FT<sup>3</sup>) may be determined by consulting the local natural gas utility or the L.P. gas supplier.

## B. LP CONVERSION

### ▲ WARNING

**THIS UNIT IS EQUIPPED AT THE FACTORY FOR USE ON NATURAL GAS ONLY. CONVERSION TO LP GAS REQUIRES A SPECIAL KIT SUPPLIED BY THE DISTRIBUTOR OR MANUFACTURER. MAILING ADDRESSES ARE LISTED ON THE FURNACE RATING PLATE, PARTS LIST AND WARRANTY. FAILURE TO USE THE PROPER CONVERSION KIT CAN CAUSE FIRE, CARBON MONOXIDE POISONING, EXPLOSION, PERSONAL INJURY, PROPERTY DAMAGE OR DEATH.**

Convert the unit to use liquefied petroleum (LP) gas by replacing with the gas valve supplied in the conversion kit. The LP gas valve maintains the proper manifold pressure for LP gas. The correct burner LP orifices are included in the kit.

**IMPORTANT:** To remove the natural gas valve, remove the four screws securing the manifold pipe to the burner tray. Remove the manifold pipe with gas valve attached.

**NOTE:** Order the correct LP conversion kit from the furnace manufacturer. **See Conversion Kit Index shipped with unit for proper LP kit number. Furnace conversion to LP gas must be performed by a qualified technician.**

**TABLE 11**  
LP GAS PIPE CAPACITY TABLE (CU. FT./HR.)

Maximum capacity of pipe in thousands of BTU per hour of undiluted liquefied petroleum gases (at 11 inches water column inlet pressure).  
(Based on a Pressure Drop of 0.5 Inch Water Column)

Nominal Iron Pipe Size, Inches	Length of Pipe, Feet												
	10	20	30	40	50	60	70	80	90	100	125	150	
1/2	275	189	152	129	114	103	96	89	83	78	69	63	
3/4	567	393	315	267	237	217	196	182	173	162	146	132	
1	1,071	732	590	504	448	409	378	346	322	307	275	252	
1-1/4	2,205	1,496	1,212	1,039	913	834	771	724	677	630	567	511	
1-1/2	3,307	2,299	1,858	1,559	1,417	1,275	1,181	1,086	1,023	976	866	787	
2	6,221	4,331	3,465	2,992	2,646	2,394	2,205	2,047	1,921	1,811	1,606	1,496	

Example (LP): Input BTU requirement of unit, 150,000  
Equivalent length of pipe, 60 ft. = 3/4" IPS required.

## C. ADJUSTING OR CHECKING FURNACE INPUT

- Natural Gas Line Pressure 5" - 10.5" W.C.
- LP Gas Line Pressure 11" - 13" W.C.
- Natural Gas Manifold Pressure 3.5" W.C.
- LP Gas Manifold Pressure - 10" W.C.

Supply and manifold pressure taps are located on the gas valve body 1/8" N.P.T. and on the manifold.

Use a properly calibrated manometer gauge for accurate gas pressure readings.

Only small variations in the gas flow should be made by means of the pressure regulator adjustment. Furnaces functioning on LP gas must be set by means of the tank or branch supply regulators. The furnace manifold pressure should be set at 10" W.C. at the gas control valve.

To adjust the pressure regulator, remove the regulator cap and turn the adjustment screw clockwise to increase pressure or counterclockwise to decrease pressure. **Then replace the regulator cap securely.**

Any necessary major changes in the gas flow rate should be made by changing the size of the burner orifices. To change orifice spuds, shut off the manual main gas valve and remove the gas manifold.

For elevations up to 2,000 feet, rating plate input ratings apply. For high altitudes (elevations over 2,000 ft.), see conversion kit index 92-21519-XX for derating and orifice spud sizes.

**Check of input is important to prevent over-firing of the furnace beyond its design-rated input. NEVER SET INPUT ABOVE THAT SHOWN ON THE RATING PLATE. Use the following table or formula to determine input rate.**

**TABLE 12**

		METER TIME IN MINUTES AND SECONDS FOR NORMAL INPUT RATING OF FURNACES EQUIPPED FOR NATURAL OR LP GAS									
INPUT BTU/HR	METER SIZE CU. FT.	HEATING VALUE OF GAS BTU PER CU. FT.									
		900		1000		1040		1100		2500	
		MIN.	SEC.	MIN.	SEC.	MIN.	SEC.	MIN.	SEC.	MIN.	SEC.
150,000	ONE TEN	3	21.6	4	24.0	4	25.0	4	26.4	1	0.0
			36	0		10		24	10	0	
220,000	ONE TEN	2	14.7	2	16.4	2	17.0	3	18.0	6	40.9
			28		44		51		0	50	
250,000	ONE TEN	2	13.0	2	14.4	2	15.0	2	15.8	6	36.0
			10		24		30		39	0	

$$\text{Cu. Ft. Per Hr. Required} = \frac{\text{Heating Value of Gas (BTU/Cu. Ft.)} \times 3600}{\text{Time in Seconds (for 1 Cu. Ft.) of Gas}}$$

Start the furnace and measure the time required to burn one cubic foot of gas. Prior to checking the furnace input, make certain that all other gas appliances are shut off, with the exception of pilot burners. Time the meter with only the furnace in operation.

**IMPORTANT NOTE FOR ALTITUDES ABOVE 2,000 FEET (610 METERS):** The main burner orifices in your furnace and in these kits are sized for the nameplate input and intended for installations at elevations up to 2,000 feet in the USA or Canada, or for elevations of 2,000 - 4,500 feet (610 - 1,373 meters) in Canada if the unit has been derated at the factory. For

elevations above 2,000 feet (610 meters) **IN THE USA ONLY** (see ANSI-Z223.1), the burner orifices must be sized to reduce the input 4% for each 1,000 feet (305 meters) above sea level.

**NOTICE: DERATING OF THE HEATING INPUT FOR HIGH ALTITUDE IN THE FIELD IS UNLAWFUL IN CANADA (REFER TO CAN/CGA 2.17). UNITS INSTALLED IN ALTITUDES GREATER THAN 2,000 FEET (610 METERS) MUST BE SHIPPED FROM THE FACTORY OR FROM A FACTORY AUTHORIZED CONVERSION STATION WITH THE HEATING INPUT DERATED BY 10% SO AS TO OPERATE PROPERLY IN ALTITUDES FROM 2,000 - 4,500 FEET (610 - 1,373 METERS).**

## D. CONDENSATE DRAIN

**IMPORTANT: Install a condensate trap to ensure proper condensate drainage. See Figure 15.**

The condensate drain pan has a threaded female 1 inch NPT (11.5 TPI) connection. Consult local codes or ordinances for specific requirements of condensate drain piping and disposal.

- To use the removable drain pan feature of this unit, some of the condensate line joints should be assembled for easy removal and cleaning.
- Use a thin layer of Teflon tape or paste on drain pan connections and install only hand tight.
- Do not over tighten drain pan connections as damage to the drain pan may occur.
- Drain line **MUST NOT** block service access panels.
- Drain line must be no smaller than drain pan outlet and adequately sized to accommodate the condensate discharge from the unit.
- Drain line should slope away from unit a minimum of 1/8" per foot to ensure proper drainage.
- Drain line must be routed to an acceptable drain or outdoors in accordance with local codes.
- Do not connect condensate drain line to a closed sewer pipe.
- Drain line may need insulation or freeze protection in certain applications.

**FIGURE 15**  
CONDENSATE DRAIN

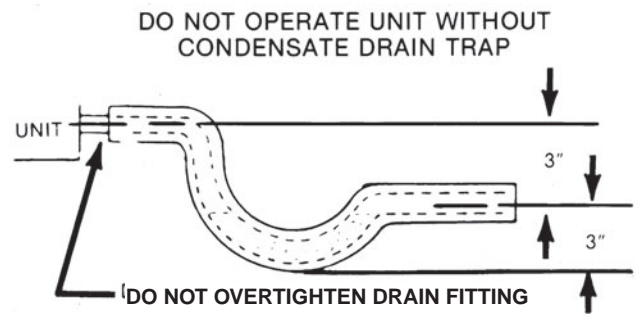

# IV. WIRING

## A. POWER SUPPLY

### ▲ WARNING

**TURN OFF THE MAIN ELECTRICAL POWER AT THE BRANCH CIRCUIT DISCONNECT CLOSEST TO THE UNIT BEFORE ATTEMPTING ANY WIRING. FAILURE TO DO SO CAN CAUSE ELECTRICAL SHOCK RESULTING IN PERSONAL INJURY OR DEATH.**

1. All wiring should be made in accordance with the National Electrical Code. Consult the local power company to determine the availability of sufficient power to operate the unit. Check the voltage at power supply to make sure it corresponds to the unit's RATED VOLTAGE REQUIREMENT. Install a branch circuit disconnect near the rooftop, in accordance with the N.E.C., C.E.C. or local codes.
2. It is important that proper electrical power is available at the unit. Voltage should not vary more than 10% from that stamped on the unit nameplate. On three phase units, phases must be balanced within 3%.
3. For branch circuit wiring (main power supply to unit disconnect), the minimum wire size for the length of run can be determined from Table 10 using the circuit ampacity found on the unit rating plate. Use the smallest wire size allowable in Table 13 from the unit disconnect to unit.

**TABLE 13**

AWG Copper Wire Size	AWG Aluminum Wire Size	Connector Type and Size (or equivalent)
#12	#10	T & B Wire Nut PT2
#10	# 8	T & B Wire Nut PT3
# 8	# 6	Sherman Split Bolt TSP6
# 6	# 4	Sherman Split Bolt TSP4
# 4	# 2	Sherman Split Bolt TSP2

4. For through the base wiring entry reference **Figure 17**. All fittings and conduit are field supplied for this application. Reference the chart with **Figure 17** for proper hole and conduit size.

**NOTES:**

1. For branch circuit wiring (main power supply to unit disconnect), the minimum wire size for the length of run can be determined from this table using the circuit ampacity found on the unit rating plate. From the unit disconnect to unit, the smallest wire size allowable in Table 1 may be used, as the disconnect must be in sight of the unit.
2. Wire size based on 75°C rated wire insulation for 1% voltage drop.
3. For more than 3 conductors in a raceway or cable, see the N.E.C. (C.E.C. in Canada) for derating the ampacity of each conductor.

**IMPORTANT: THIS UNIT IS AP - PROVED FOR USE WITH COPPER CONDUCTORS ONLY CONNECTED TO UNIT CONTACTOR.**

**WARRANTY MAY BE JEOPARDIZED IF ALUMINUM WIRE IS CONNECTED TO UNIT CONTACTOR.**

**Special instructions apply for power wiring with aluminum conductors: Warranty is void if connections are not made per instructions.**

Attach a length (6" or more) of recommended size copper wire to the unit contactor terminals L1, L2 and L3 for three phase.

Select the equivalent aluminum wire size from the tabulation below:

Splice copper wire pigtails to aluminum wire with U.L. recognized connectors for copper-aluminum splices. Please exercise the following instructions very carefully to obtain a positive and lasting connection:

1. Strip insulation from aluminum conductor.
2. Coat the stripped end of the aluminum wire with the recommended inhibitor, and wire brush the aluminum surface through inhibitor. INHIBITORS: Brundy-Pentex "A"; Alcoa-No. 2EJC; T & B-KPOR Shield.
3. Clean and recoat aluminum conductor with inhibitor.
4. Make the splice using the above listed wire nuts or split bolt connectors.
5. Coat the entire connection with inhibitor and wrap with electrical insulating tape.

**TABLE 14**

UNIT MCA	COPPER WIRE SIZE—AWG					
	SUPPLY WIRE LENGTH—FEET					
	50	100	150	200	250	300
20	10	8	6	4	4	4
25	10	8	6	4	4	3
30	8	6	4	4	3	2
35	8	6	4	3	2	1
40	8	6	4	3	2	1
45	8	4	3	2	1	1/0
50	6	4	3	2	1	1/0
60	6	4	2	1	1/0	2/0
70	4	3	2	1/0	2/0	3/0
80	4	3	1	1/0	2/0	3/0
90	3	2	1/0	2/0	3/0	4/0
100	3	2	1/0	2/0	3/0	4/0
110	2	1	2/0	3/0	4/0	250
125	1	1	2/0	3/0	4/0	250

**FIGURE 16**  
RECOMMENDED BRANCH CIRCUIT DISCONNECT LOCATION

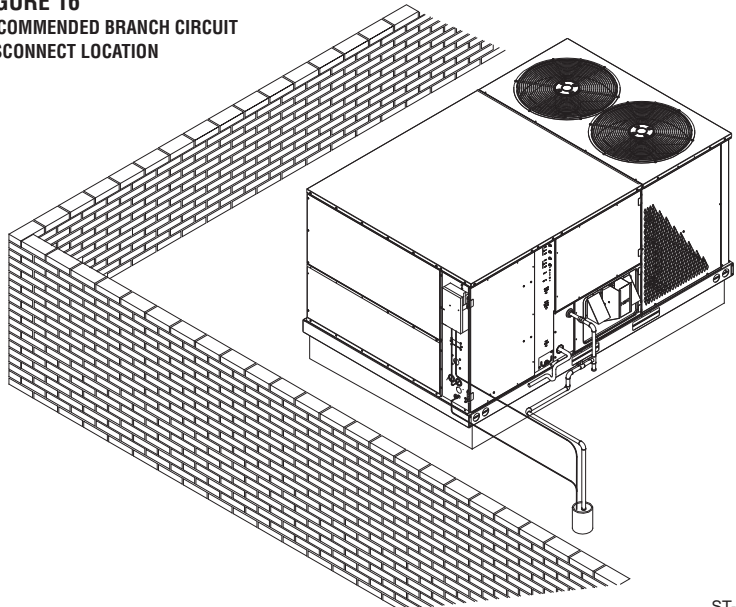

ST-A1111-03



**FIGURE 17**

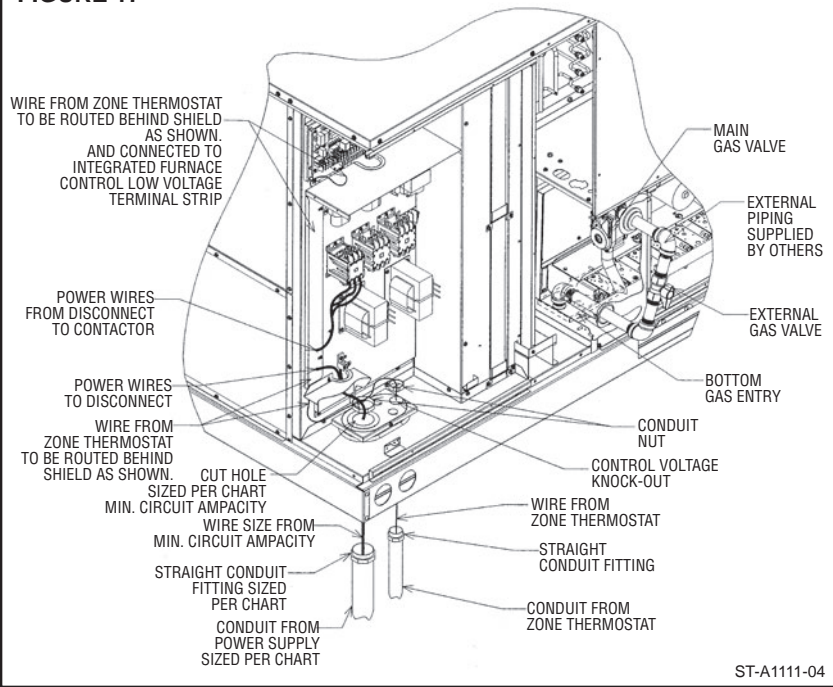

**FIGURE 18  
TYPICAL THERMOSTAT WIRING**

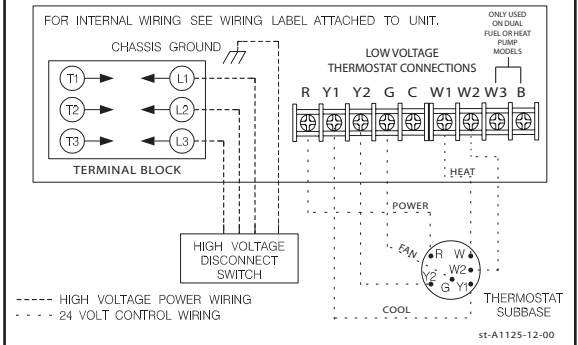

	WIRE SIZE, AWG											
	14	12	10	8	6	4	3	2	1	0	00	000
CONDUIT SIZE	1/2"	1/2"	1/2"	3/4"	1"	1"	1-1/4"	1-1/4"	1-1/2"	1-1/2"	2"	2"
HOLE SIZE	7/8"	7/8"	7/8"	1-31/32"	1-23/64"	1-23/64"	1-23/32"	1-23/32"	1-31/32"	1-31/32"	2-15/32"	2-15/32"

NOTES: 1. DETERMINE REQUIRED WIRE SIZE FROM MINIMUM CIRCUIT AMPACITY SHOWN IN INSTALLATION & OPERATING INSTRUCTION.  
2. BOTTOM POWER ENTRY WILL NOT ACCOMMODATE WIRE LARGER THAN #2 AWG (SHADED AREA).

**B. HOOK-UP**

To wire unit, refer to the following hook-up diagram.

Refer to Figures 2 and 17 for location of wiring entrances.

Wiring to be done in the field between the unit and devices not attached to the unit, or between separate devices which are field installed and located, shall conform with the temperature limitation for Type T wire [63°F rise (35°C)] when installed in accordance with the manufacturer’s instructions.

**C. INTERNAL WIRING**

A diagram of the internal wiring of this unit is located on the inside of control access panel and in this manual. If any of the original wire as supplied with the appliance must be replaced, the wire gauge and insulation must be same as original wiring.

Transformer is factory wired for 230 volts on 208/230 volt models and must be changed for 208 volt applications. See unit wiring diagram for 208 volt wiring.

**D. THERMOSTAT**

The room thermostat must be compatible with the spark ignition control on the unit. Generally, all thermostats that are not of the “current robbing” type are compatible with the integrated furnace control. The low voltage wiring should be sized as shown in Table 10.

Install the room thermostat in accordance with the instruction sheet packed in the box with the thermostat. Run the thermostat lead wires through control entry opening (Figure 2 or Figure 17) and connect to the low voltage thermostat connections (see wiring diagram). Never install the thermostat on an outside wall or where it will be influenced by drafts, concealed hot or cold water pipes or ducts, lighting fixtures, radiation from fireplace, sun rays,

lamps, televisions, radios or air streams from registers. Refer to instructions packed with the thermostat for “heater” selection or adjustment.

The following is a list of recommended thermostats to be used with or without an economizer:

**TABLE 15**

FIELD WIRE SIZE FOR 24 VOLT THERMOSTAT CIRCUITS						
Thermostat Load - Amps		SOLID COPPER WIRE - AWG.				
		3.0	16	14	12	10
2.5	16	14	12	12	12	10
2.0	18	16	14	12	12	10
	50	100	150	200	250	300
		Length of Run – Feet (1)				

(1) The total wire length is the distance from the thermostat and back to the furnace.

**NOTE: DO NOT USE CONTROL WIRING SMALLER THAN NO. 18 AWG.**

# V. FURNACE SECTION CONTROLS AND IGNITION SYSTEM

## NORMAL FURNACE OPERATING SEQUENCE

This unit is equipped with a two stage integrated direct spark ignition control.

### NORMAL HEAT MODE

#### A. Call For First Stage (low fire) Only:

1. Zone thermostat contacts close, a call for first stage (low fire) heat is initiated.
2. Control runs self check.
3. Control checks the high-limit switch for normally closed contacts, each pressure switch for normally open contacts, and all flame rollout switches for continuity.
4. Control energizes each low-fire inducer.
5. Control checks each low-fire pressure switch for closure.
6. If each low-fire pressure switch is closed, the control starts a 30 second prepurge. If either low-fire pressure switch is still open after 180 seconds, the high-fire inducers will be energized until closure.
7. After prepurge timeout, control initiates spark for 2 seconds minimum, 7 second maximum ignition trial, initiates 45 second, second stage (high fire) warm up timing.
8. Control detects flame, de-energizes spark and initiates 45 second delay on blower timing.
9. After a fixed 45 seconds indoor blower delay on, the control energizes the indoor blower.
10. After the 45 second second stage warmup period control checks thermostat input. If only W1 is called for, W2 is de-energized and the control starts a 5 second off delay on the W2 inducer.
11. After fixed 5 seconds the W2 inducer is de-energized.
12. Control enters normal operating loop where all inputs are continuously checked.

#### B. Call For Second Stage, After First Stage Established; Starting from A.11:

1. If a call for second stage (high fire) is initiated after a call for first stage heat is established, the control energizes the W2 inducer assures the high-fire pressure switch is closed and energizes the second stage of the gas valve.
2. Control enters normal operating loop where all inputs are continuously checked.

#### C. Second Stage Satisfied; First Stage Still Called For; Starting From B.2:

1. Once the call for second stage is satisfied, the control starts a 30 second off delay on W2 inducer and reduces the gas valve to first stage.
2. Control enters normal operating loop where all inputs are continuously checked.

#### D. First Stage Satisfied:

1. Zone thermostat is satisfied.

2. Control de-energizes gas valve.
3. Control senses loss of flame.
4. Control initiates 5 second inducer postpurge and 90 second indoor blower delay off.
5. Control de-energizes inducer blower.
6. Control de-energizes indoor blower.
7. Control in the stand by mode with solid red LED.

#### E. First Stage and Second Stage Called Simultaneously:

1. Zone thermostat contacts close, a call for first stage (low fire) and second stage (high fire) heat is initiated.
2. Control runs self check.
3. Control checks the high-limit switch for normally closed contacts, each pressure switch for normally open contacts, and all flame rollout switches for continuity.
4. Control energizes each low-fire inducer.
5. Control checks each pressure switch for closure.
6. If each low-fire pressure switch is closed, the control starts a 30 second prepurge. If either switch is still open after 180 seconds, the high-fire inducers will be energized until closure.
7. After prepurge timeout, control initiates spark for 2 seconds minimum, 7 second maximum ignition trial, and initiates 45 second second stage warm up timing.
8. Control detects flame, de-energizes spark and starts a 45 second indoor blower delay on timing.
9. After a fixed 45 seconds indoor blower delay on, the control energizes the indoor blower.
10. After the 45 seconds second stage warmup period control checks the thermostat input. If W1 and W2 is present control enters normal operating loop where all inputs are continuously checked.

#### F. First Stage and Second Stage Removed Simultaneously:

1. Upon a loss of W1 and W2 the gas valve is de-energized.
2. Upon a loss of flame, each inducer will complete a 5 second postpurge and the indoor blower will complete a 90 second delay off.
3. Control in the stand by mode with solid red LED.

The integrated control is a four-ignition system.

After a total of four cycles without sensing main burner flame, the system goes into a 100% lockout mode. After one hour, the ignition control repeats the prepurge and ignition cycles for 4 tries and then go into 100% lockout mode again. It continues this sequence of cycles and lockout each hour until ignition is successful or power is interrupted. During the lockout mode, neither the ignitor or gas valve will be energized until the system is reset by turning the thermostat to the "OFF"

position or interrupting the electrical power to the unit for 3 seconds or longer. The induced draft blower and main burner will shut off when the thermostat is satisfied.

The circulating air blower will start and run on the heating speed if the thermostat fan switch is in the "ON" position.

The integrated furnace control is equipped with diagnostic LED. The LED is lit continuously when there is power to the control, with or without a call for heat. If the LED is not lit, there is either no power to the control or there is an internal component failure within the control, and the control should be replaced.

If the control detects the following failures, the LED will flash on for approximately 1/4 second, then off for 3/4 second for designated failure detections.

- 1 Flash: Failed to detect flame within the four tries for ignition.
- 2 Flash: Pressure switch or induced draft blower problem detected.
- 3 Flash: High limit or auxiliary limit open.
- 4 Flash: Flame sensed and gas valve not energized or flame sensed with no "W" signal.
- 5 Flash: Overtemperature switch open.

## OPERATING INSTRUCTIONS

This appliance is equipped with integrated furnace control. This device lights the main burners each time the room thermostat (closes) calls for heat. See operating instructions on the back of the furnace/controls access panel.

### **▲ WARNING**

**DO NOT ATTEMPT TO MANUALLY LIGHT THIS FURNACE WITH A MATCH OR ANY OPEN FLAME. ATTEMPTING TO DO SO CAN CAUSE AN EXPLOSION OR FIRE RESULTING IN PROPERTY DAMAGE, PERSONAL INJURY OR DEATH.**

#### TO START THE FURNACE

1. Set the thermostat to its lowest setting.
2. Turn off all electric power to the appliance.
3. This appliance does not have a pilot. It is equipped with an ignition device which automatically lights the burner. Do not try to light the burner by hand.
4. Remove control door.
5. Move control knob to the "OFF" position. Turn the knob by hand only, do not use any kind of tool.
6. Wait five (5) minutes to clear out any gas. Then smell for gas, including near the floor. If you smell gas, STOP! Follow B in the safety information on the Operating Instructions located on the back of the controls/access panel. If you don't smell gas, go to the next step.

7. Move the gas control knob from "OFF" position to "ON" position. Operate this appliance with the gas control knob in the "ON" position only. Do not use the gas control knob as a means for throttling the burner input rate.
8. Replace the control door.
9. Turn on all electric power to the appliance.
10. Set the thermostat to the desired setting.
11. If the appliance will not operate, follow the instructions below on how to shut down the furnace.

**▲ WARNING**

**THE SPARK IGNITOR AND IGNITION LEAD FROM THE IGNITION CONTROL ARE HIGH VOLTAGE. KEEP HANDS OR TOOLS AWAY TO PREVENT ELECTRICAL SHOCK. SHUT OFF ELECTRICAL POWER BEFORE SERVICING ANY OF THE CONTROLS. FAILURE TO ADHERE TO THIS WARNING CAN RESULT IN PERSONAL INJURY OR DEATH.**

The initial start-up on a new installation may require the control system to be energized for some time until air has bled through the system and fuel gas is available at the burners.

**TO SHUT DOWN FURNACE**

1. Set the thermostat to the lowest setting.
2. Turn off all electric power to the appliance if service is to be performed.
3. Remove control door.

4. Move control knob to the "OFF" position.
5. Replace control door.

**▲ WARNING**

**SHOULD OVERHEATING OCCUR OR THE GAS SUPPLY FAIL TO SHUT OFF, SHUT OFF THE MANUAL GAS VALVE TO THE APPLIANCE BEFORE SHUTTING OFF THE ELECTRICAL SUPPLY. FAILURE TO DO SO CAN RESULT IN AN EXPLOSION OR FIRE CAUSING PROPERTY DAMAGE, SEVERE PERSONAL INJURY OR DEATH!**

**BURNERS**

Burners for these units have been designed so that field adjustment is not required. Burners are tray-mounted and accessible for easy cleaning when required.

**MANUAL RESET OVERTEMPERATURE CONTROL**

Two manual reset overtemperature controls are located on the burner shield. These devices senses blockage in the heat exchanger or insufficient combustion air. This shuts off the main burners if excessive temperatures occur in the burner compartment.

Operation of this control indicates an abnormal condition. Therefore, the unit should be examined by a qualified installer, service agency, or the gas

supplier before being placed back into operation.

**▲ WARNING**

**DO NOT JUMPER THIS DEVICE! DO NOT RESET THE OVERTEMPERATURE CONTROL WITHOUT TAKING CORRECTIVE ACTION TO ASSURE THAT AN ADEQUATE SUPPLY OF COMBUSTION AIR IS MAINTAINED UNDER ALL CONDITIONS OF OPERATION. FAILURE TO DO SO CAN RESULT IN CARBON MONOXIDE POISONING OR DEATH. REPLACE THIS CONTROL ONLY WITH THE IDENTICAL REPLACEMENT PART.**

**PRESSURE SWITCH**

This furnace has two pressure switches for sensing a blocked exhaust or a failed induced draft blower. They are normally open and close when the induced draft blower starts, indicating air flow through the combustion chamber.

**LIMIT CONTROL**

The supply air high temperature limit cut-off is set at the factory and cannot be adjusted. It is calibrated to prevent the air temperature leaving the furnace from exceeding the maximum outlet air temperature.

**▲ WARNING**

**DO NOT JUMPER THIS DEVICE! DOING SO CAN CAUSE A FIRE OR EXPLOSION RESULTING IN PROPERTY DAMAGE, PERSONAL INJURY OR DEATH.**

**IMPORTANT:** Replace this control only with the identical replacement part.

**VI. SYSTEM OPERATING INFORMATION**

**ADVISE THE CUSTOMER**

1. Change the air filters regularly. The heating system operates better, more efficiently and more economically.
2. Arrange the furniture and drapes so that the supply air registers and the return air grilles are unobstructed.
3. Close doors and windows. This reduces the heating and cooling load on the system.
4. Avoid excessive use of exhaust fans.
5. Do not permit the heat generated by television, lamps or radios to influence the thermostat operation.
6. Except for the mounting platform, keep all combustible articles three feet from the unit and exhaust system.
7. **IMPORTANT:** Replace all blower doors and compartment cover after servicing the unit. Do not operate the unit without all panels and doors securely in place.
8. Do not allow snow or other debris to accumulate in the vicinity of the appliance.

**FURNACE SECTION MAINTENANCE**

The unit's furnace should operate for many years without excessive scale build-up in flue passageways; however, it is recommended that a qualified installer, service agency, or the gas supplier annually inspect the flue passageways, the exhaust system and the burners for continued safe operation, paying particular attention to deterioration from corrosion or other sources.

If during inspection the flue passageways and exhaust system are determined to require cleaning, the following procedures should be followed (**by a qualified installer, service agency, or gas supplier**):

1. Turn off the electrical power to the unit and set the thermostat to the lowest temperature.
2. Shut off the gas supply to the unit either at the meter or at manual valve in the supply piping.

**▲ WARNING**

**LABEL ALL WIRES PRIOR TO DISCONNECTION WHEN SERVICING CONTROLS. WIRING ERRORS CAN**

**CAUSE IMPROPER AND DANGEROUS OPERATION RESULTING IN FIRE, ELECTRICAL SHOCK, PROPERTY DAMAGE, PERSONAL INJURY OR DEATH.**

3. Remove the furnace controls access panel and the control box cover.
4. Disconnect the gas supply piping from the gas valve.
5. Disconnect the wiring to the induced draft blower motor, gas valve, flame sensor, and flame roll-out control, and ignitor cable. **Mark all wires disconnected for proper reconnection.**
6. Remove the screws (4) connecting the burner tray to the heat exchanger mounting panel.
7. Remove the burner tray and the manifold assembly from the unit.
8. Remove the screws (10) connecting the two induced draft blowers to the collector box and screws (12) connecting the inducer mounting plate to the heat exchanger center panel. Remove the induced draft blower and the collector box from the unit.
9. Remove the turbulators from inside the heat exchangers by inserting the blade of a screwdriver under the locking tabs. Pop the tabs out of the expanded

grooves of the heat exchanger. Slide the turbulators out of the heat exchangers.

10. Direct a water hose into the outlet of the heat exchanger top. Flush the inside of each heat exchanger tube with water. Blow out each tube with air to remove excessive moisture.
11. Reassemble (steps 1 through 9 in reverse order). **Be careful not to strip out the screw holes used to mount the collector box and inducer blower. Replace inducer blower gasket and collector box gasket with factory replacements if damaged.**

#### **▲ WARNING**

**HOLES IN THE EXHAUST TRANSITION OR HEAT EXCHANGER CAN CAUSE TOXIC FUMES TO ENTER THE HOME. THE EXHAUST TRANSITION OR HEAT EXCHANGER MUST BE REPLACED IF THEY HAVE HOLES OR CRACKS IN THEM. FAILURE TO DO SO CAN CAUSE CARBON MONOXIDE POISONING RESULTING IN PERSONAL INJURY OR DEATH.**

The manufacturer recommends that a qualified installer, service agency or the gas supplier visually inspect the burner flames for the desired flame appearance at the beginning of the heating season and approximately midway in heating season.

The manufacturer also recommends that a qualified installer, service agency or the gas supplier clean the flame sensor with steel wool at the beginning of the heating season.

#### **▲ WARNING**

**DISCONNECT MAIN ELECTRICAL POWER TO THE UNIT BEFORE ATTEMPTING MAINTENANCE. FAILURE TO DO SO MAY RESULT IN ELECTRICAL SHOCK OR SEVERE PERSONAL INJURY OR DEATH.**

## LUBRICATION

**IMPORTANT: DO NOT** attempt to lubricate the bearings on the blower motor or the induced draft blower motor. Addition of lubricants can reduce the motor life and void the warranty.

The blower motor and induced draft blower motor are prelubricated by the manufacturer and do not require further attention.

A qualified installer, service agency or the gas supplier must periodically clean the motors to prevent the possibility of overheating due to an accumulation of dust and dirt on the windings or on the motor exterior. And, as suggested elsewhere in these instructions, the air filters should be kept clean because dirty filters can restrict air flow and the motor depends upon sufficient air flowing across and through it to prevent overheating.

## COOLING SECTION MAINTENANCE

#### **▲ WARNING**

**DISCONNECT MAIN ELECTRICAL POWER TO THE UNIT BEFORE ATTEMPTING MAINTENANCE. FAILURE TO DO SO CAN CAUSE ELECTRICAL SHOCK RESULTING IN SEVERE PERSONAL INJURY OR DEATH.**

It is recommended that at the beginning of each cooling season a qualified installer or service agency inspect and clean the cooling section of this unit. The following areas should be addressed: evaporator coil, condenser coil, condenser fan motor and venturi area.

#### **To inspect the evaporator coil:**

1. Open the control/filter access panel and remove filters. Also, remove blower access panel. In downflow applications remove the horizontal return to gain access.

#### **▲ WARNING**

**LABEL ALL WIRES PRIOR TO DISCONNECTION WHEN SERVICING THE UNIT. WIRING ERRORS CAN CAUSE IMPROPER AND DANGEROUS OPERATION RESULTING IN FIRE, ELECTRICAL SHOCK, PROPERTY DAMAGE, SEVERE PERSONAL INJURY OR DEATH.**

2. Shine a flashlight on the evaporator coil (both sides) and inspect for accumulation of lint, insulation, etc.
3. If coil requires cleaning, follow the steps shown below.

#### **Cleaning Evaporator Coil**

1. The coil should be cleaned when it is dry. If the coil is coated with dirt or lint, vacuum it with a soft brush attachment. Be careful not to bend the coil fins.
2. If the coil is coated with oil or grease, clean it with a mild detergent-and-water solution. Rinse the coil thoroughly with water. **IMPORTANT: Do not** use excessive water pressure. Excessive water pressure can bend the fins and tubing of the coil and lead to inadequate unit performance. Be careful not to splash water excessively into unit.
3. Inspect the drain pan and condensate drain at the same time the evaporator coil is checked. Clean the drain pan by flushing with water and removing any matters of obstructions which may be present.
4. Go to next section for cleaning the condenser coil.

#### **Cleaning Condenser Coil, Condenser Fan, Circulation Air Blower and Venturi**

1. Remove the compressor access panel. Disconnect the wires to the condenser fan motor in the control box (see wiring diagram).
2. The coil should be cleaned when it is dry. If the coil is coated with dirt or lint, vacuum it with a soft brush attachment. Be careful not to bend the coil fins.
3. If the coil is coated with oil or grease, clean it with a mild detergent-and-water solution. Rinse the coil thoroughly with water. **IMPORTANT: Do not** use excessive water pressure. Excessive water pressure can bend the fins and tubing of the coil and lead to inadequate unit performance. Be careful not to splash water excessively into unit.
4. The venturi should also be inspected for items of obstruction such as collections of grass, dirt or spider webs. Remove any that are present.
5. Inspect the circulating air blower wheel and motor for accumulation of lint, dirt or other obstruction and clean it necessary. Inspect the blower motor mounts and the blower housing for loose mounts or other damage. Repair or replace if necessary.

#### **Re-assembly**

1. Reconnect fan motor wires per the wiring diagram attached to the back of the cover.
2. Close the filter control and replace the blower/evaporator coil access panels.
3. Replace the control box cover.
4. Restore electrical power to the unit and check for proper operation, especially the condenser fan motor.

## REPLACEMENT PARTS

Contact your local distributor for a complete parts list.

## TROUBLESHOOTING

Refer to Figures 19 and 20 for determining cause of unit problems.

## WIRING DIAGRAMS

Figures 21 through 28 are complete wiring diagrams for the unit and its power sources. Also located on back of compressor access panel.

## CHARGING

See Figures 29 through 40 for proper charging information.

**TABLE 16 - AIR-FLOW PERFORMANCE – 7.5 TON RKRL-C090 MODELS**

Capacity	7.5 Ton [26.4 kW]																																								
	External Static Pressure—Inches of Water [kPa]																																								
	0.1 [1.02]	0.2 [0.05]	0.3 [0.07]	0.4 [1.10]	0.5 [1.12]	0.6 [1.15]	0.7 [1.17]	0.8 [2.0]	0.9 [1.22]	1.0 [1.25]	1.1 [1.27]	1.2 [1.30]	1.3 [1.32]	1.4 [1.35]	1.5 [1.37]	1.6 [1.40]	1.7 [1.42]	1.8 [1.45]	1.9 [1.47]	2.0 [1.50]																					
Air Flow CFM [L/s]	RPM	W	RPM	W	RPM	W	RPM	W	RPM	W	RPM	W	RPM	W	RPM	W	RPM	W	RPM	W																					
2400 [1133]	—	—	540	580	582	664	612	729	645	812	711	890	740	952	770	1014	799	1076	828	1138	857	1200	887	1261	929	1538	958	1623	987	1709	1017	1794	1046	1879	1075	1965	1105	2050			
2500 [1180]	—	—	—	—	552	633	593	717	624	791	656	878	720	950	1012	778	1074	808	1136	837	1198	866	1260	895	1322	936	1602	965	1687	995	1773	1024	1858	1053	1944	1083	2029	1112	2114		
2600 [1227]	—	—	—	—	—	564	687	603	769	635	853	667	945	729	1010	758	1072	787	1134	816	1196	846	1258	875	1320	914	1581	943	1666	972	1751	1021	1837	1031	1922	1061	2008	1090	2093	1119	2178
2700 [1274]	—	—	539	670	577	744	614	828	648	923	680	1017	737	1070	766	1132	796	1194	825	1256	854	1318	883	1380	921	1645	950	1730	980	1816	1009	1901	1038	1986	1068	2072	1097	2157	1127	2243	
2800 [1321]	—	—	—	554	733	590	801	625	887	660	983	708	1069	746	1131	775	1192	804	1254	834	1316	863	1378	892	1440	928	1709	958	1794	987	1880	1016	1965	1046	2050	1075	2136	1104	2221	1134	2307
3000 [1416]	546	741	854	869	617	931	650	1024	685	1144	734	1189	763	1251	792	1313	822	1375	851	1437	880	1498	913	1752	943	1837	972	1923	1002	2008	1031	2093	1060	2179	1090	2264	1119	2350	1148	2435	
3100 [1463]	560	804	598	940	632	1010	664	1107	713	1187	743	1249	772	1311	801	1373	830	1435	860	1497	889	1559	921	1816	950	1901	979	1987	1009	2072	1038	2157	1068	2243	1097	2328	1126	2414	1156	2499	
3200 [1510]	576	876	612	1011	646	1089	678	1189	722	1247	751	1309	781	1371	810	1433	839	1495	868	1557	898	1619	928	1880	957	1965	987	2051	1016	2136	1045	2222	1075	2307	1104	2392	1134	2478	1163	2563	
3300 [1557]	592	954	628	1096	660	1168	692	1274	731	1307	760	1369	789	1431	818	1493	848	1555	877	1617	906	1859	935	1944	965	2029	994	2115	1023	2200	1053	2286	1082	2371	1111	2456	1141	2542	1170	2627	
3400 [1605]	607	1030	643	1180	673	1247	710	1306	739	1368	769	1430	798	1491	827	1553	856	1615	886	1677	913	1923	943	2008	972	2094	1001	2179	1031	2264	1060	2350	1089	2435	1119	2521	1148	2606	1178	2691	
3500 [1652]	622	1112	658	1271	689	1344	719	1366	748	1428	777	1490	807	1552	836	1613	865	1675	894	1737	920	1987	950	2072	979	2158	1009	2243	1038	2328	1067	2414	1097	2499	1126	2585	1155	2670	1185	2756	
3600 [1699]	638	1202	672	1361	704	1440	728	1426	757	1488	786	1550	815	1612	844	1674	874	1735	903	1797	928	2051	957	2136	986	2222	1016	2307	1045	2393	1075	2478	1104	2563	1133	2649	1163	2734	1192	2820	

NOTE: L-Drive left of 1st bold line, M-Drive in middle of bold lines, N-Drive right of 2nd bold line.

Drive Package	L						M						N					
Motor H.P. [W]	2.0 [1491.4]						2.0 [1491.4]						3.0 [2237.1]					
Blower Sheave	BK110						BK90						BK65					
Motor Sheave	1VP-44						1VP-44						1VP-44					
Turns Open	1	2	3	4	5	6	1	2	3	4	5	6	1	2	3	4	5	6
RPM	682	650	620	587	555	523	806	774	742	710	678	646	1056	1005	954	904		

- NOTES: 1. Factory sheave settings are shown in bold print.  
 2. Re-adjustment of sheave required to achieve rated airflow at ARI minimum E.S.P.  
 3. Do not operate above blower RPM shown as motor overloading will occur.  
 4. Do not set motor sheave below one turn open.

**AIRFLOW CORRECTION FACTORS**  
**7.5 TON [26.4 kW]**

ACTUAL—CFM [L/s]	Standard Indoor Airflow—CFM [L/s]						
	2600 [1227]	2800 [1321]	3000 [1416]	3200 [1510]	3400 [1605]	3600 [1699]	3800 [1793]
TOTAL MBH	0.97	0.98	0.99	1.00	1.01	1.02	1.03
SENSIBLE MBH	0.91	0.94	0.97	1.00	1.02	1.05	1.08
POWER kW	0.99	0.99	0.99	1.00	1.00	1.01	1.02

- NOTES: 1. Multiply correction factor times gross performance data.  
 2. Resulting sensible capacity cannot exceed total capacity.

**[ ] Designates Metric Conversions**

Component	Resistance—Inches Water [kPa]											
	2400 [1133]	2600 [1227]	2800 [1321]	3000 [1416]	3200 [1510]	3400 [1604]	3600 [1699]					
Wet Coil	0.047 [0.012]	0.051 [0.013]	0.055 [0.014]	0.060 [0.015]	0.065 [0.016]	0.071 [0.018]	0.076 [0.019]					
Concentric Diffuser RXRM-FA65 or FA75 & Transition RXMC-CD04	DNA	0.17 [0.042]	0.20 [0.050]	0.25 [0.062]	0.31 [0.077]	0.37 [0.092]	DNA					
Concentric Diffuser RXRM-AA61 or AA71 & Transition RXMC-CE05	DNA	DNA	DNA	DNA	DNA	DNA	.017 [0.042]					
Economizer	0.05 [0.012]	0.06 [0.015]	0.07 [0.017]	0.08 [0.020]	0.09 [0.022]	0.10 [0.025]	0.11 [0.027]					
100% R.A. Damper Open	0.03 [0.007]	0.04 [0.009]	0.04 [0.010]	0.05 [0.011]	0.05 [0.012]	0.06 [0.014]	0.06 [0.015]					
Horizontal Economizer	0.08 [0.020]	0.08 [0.020]	0.08 [0.020]	0.10 [0.024]	0.11 [0.027]	0.12 [0.030]	0.13 [0.032]					
100% O.A. Damper Open	0.08 [0.020]	0.08 [0.020]	0.08 [0.020]	0.10 [0.024]	0.11 [0.027]	0.12 [0.030]	0.13 [0.032]					

NOTE: Add component resistance to duct resistance to determine total external static pressure.  
 DNA = Data not Available.



# FIGURE 19 COOLING TROUBLE SHOOTING CHART

**▲ WARNING**

**DISCONNECT ALL POWER TO UNIT BEFORE SERVICING. CONTACTOR MAY BREAK ONLY ONE SIDE. FAILURE TO SHUT OFF POWER CAN CAUSE ELECTRICAL SHOCK RESULTING IN PERSONAL INJURY OR DEATH.**

SYMPTOM	POSSIBLE CAUSE	REMEDY
Unit will not run	<ul style="list-style-type: none"> <li>• Power off or loose electrical connection</li> <li>• Thermostat out of calibration-set too high</li> <li>• Failed contactor</li> <li>• Blown fuses</li> <li>• Transformer defective</li> <li>• High pressure control open (if provided)</li> <li>• Interconnecting low voltage wiring damaged</li> </ul>	<ul style="list-style-type: none"> <li>• Check for correct voltage at compressor contactor in control box</li> <li>• Reset</li> <li>• Check for 24 volts at contactor coil - replace if contacts are open</li> <li>• Replace fuses</li> <li>• Check wiring-replace transformer</li> <li>• Reset-also see high head pressure remedy-The high pressure control opens at 450 PSIG</li> <li>• Replace thermostat wiring</li> </ul>
Condenser fan runs, compressor doesn't	<ul style="list-style-type: none"> <li>• Loose connection</li> <li>• Compressor stuck, grounded or open motor winding open internal overload.</li> <li>• Low voltage condition</li> <li>• Low voltage condition</li> </ul>	<ul style="list-style-type: none"> <li>• Check for correct voltage at compressor - check &amp; tighten all connections</li> <li>• Wait at least 2 hours for overload to reset. If still open, replace the compressor. At compressor terminals, voltage must be within 10% of rating plate volts when unit is operating.</li> <li>• Add start kit components</li> </ul>
Insufficient cooling	<ul style="list-style-type: none"> <li>• Improperly sized unit</li> <li>• Improper airflow</li> <li>• Incorrect refrigerant charge</li> <li>• Air, non-condensibles or moisture in system</li> <li>• Incorrect voltage</li> </ul>	<ul style="list-style-type: none"> <li>• Recalculate load</li> <li>• Check - should be approximately 400 CFM per ton.</li> <li>• Charge per procedure attached to unit service panel.</li> <li>• Recover refrigerant, evacuate &amp; recharge, add filter drier</li> <li>• At compressor terminals, voltage must be within 10% of rating plate volts when unit is operating.</li> </ul>
Compressor short cycles	<ul style="list-style-type: none"> <li>• Incorrect voltage</li> <li>• Defective overload protector</li> <li>• Refrigerant undercharge</li> </ul>	<ul style="list-style-type: none"> <li>• At compressor terminals, voltage must be <math>\pm</math> 10% of nameplate marking when unit is operating.</li> <li>• Replace - check for correct voltage</li> <li>• Add refrigerant</li> </ul>
Registers sweat	<ul style="list-style-type: none"> <li>• Low evaporator airflow</li> </ul>	<ul style="list-style-type: none"> <li>• Increase speed of blower or reduce restriction - replace air filter</li> </ul>
High head-low vapor pressures	<ul style="list-style-type: none"> <li>• Restriction in liquid line, expansion device or filter drier</li> <li>• Flow check piston size too small</li> <li>• Incorrect capillary tubes</li> <li>• TXV does not open</li> </ul>	<ul style="list-style-type: none"> <li>• Remove or replace defective component</li> <li>• Change to correct size piston</li> <li>• Change coil assembly</li> <li>• Replace TXV</li> </ul>
High head-high or normal vapor pressure - Cooling mode	<ul style="list-style-type: none"> <li>• Dirty condenser coil</li> <li>• Refrigerant overcharge</li> <li>• Condenser fan not running</li> <li>• Air or non-condensibles in system</li> </ul>	<ul style="list-style-type: none"> <li>• Clean coil</li> <li>• Correct system charge</li> <li>• Repair or replace</li> <li>• Recover refrigerant, evacuate &amp; recharge</li> </ul>
Low head-high vapor pressures	<ul style="list-style-type: none"> <li>• Defective Compressor valves</li> <li>• Incorrect capillary tubes</li> </ul>	<ul style="list-style-type: none"> <li>• Replace compressor</li> <li>• Replace coil assembly</li> </ul>
Low vapor - cool compressor - iced evaporator coil	<ul style="list-style-type: none"> <li>• Low evaporator airflow</li> <li>• Operating below 65°F outdoors</li> <li>• Moisture in system</li> </ul>	<ul style="list-style-type: none"> <li>• Increase speed of blower or reduce restriction - replace air filter</li> <li>• Add Low Ambient Kit</li> <li>• Recover refrigerant - evacuate &amp; recharge - add filter drier</li> </ul>
High vapor pressure	<ul style="list-style-type: none"> <li>• Excessive load</li> <li>• Defective compressor</li> </ul>	<ul style="list-style-type: none"> <li>• Recheck load calculation</li> <li>• Replace</li> </ul>
Fluctuating head & vapor pressures	<ul style="list-style-type: none"> <li>• TXV hunting</li> <li>• Air or non-condensibles in system</li> </ul>	<ul style="list-style-type: none"> <li>• Check TXV bulb clamp - check air distribution on coil - replace TXV</li> <li>• Recover refrigerant, evacuate &amp; recharge</li> </ul>
Gurgle or pulsing noise at expansion device or liquid line	<ul style="list-style-type: none"> <li>• Air or non-condensibles in system</li> </ul>	<ul style="list-style-type: none"> <li>• Recover refrigerant, evacuate &amp; recharge</li> </ul>

**FIGURE 20**  
**FURNACE TROUBLESHOOTING GUIDE**  
 (COMBINATION HEATING AND COOLING UNITS WITH DIRECT SPARK IGNITION)

**⚠ WARNING**



**HAZARDOUS VOLTAGE**  
**LINE VOLTAGE**  
**CONNECTIONS**

**DISCONNECT POWER BEFORE**  
**SERVICING.**  
**SERVICE MUST BE BY A TRAINED,**  
**QUALIFIED SERVICE TECHNICIAN.**

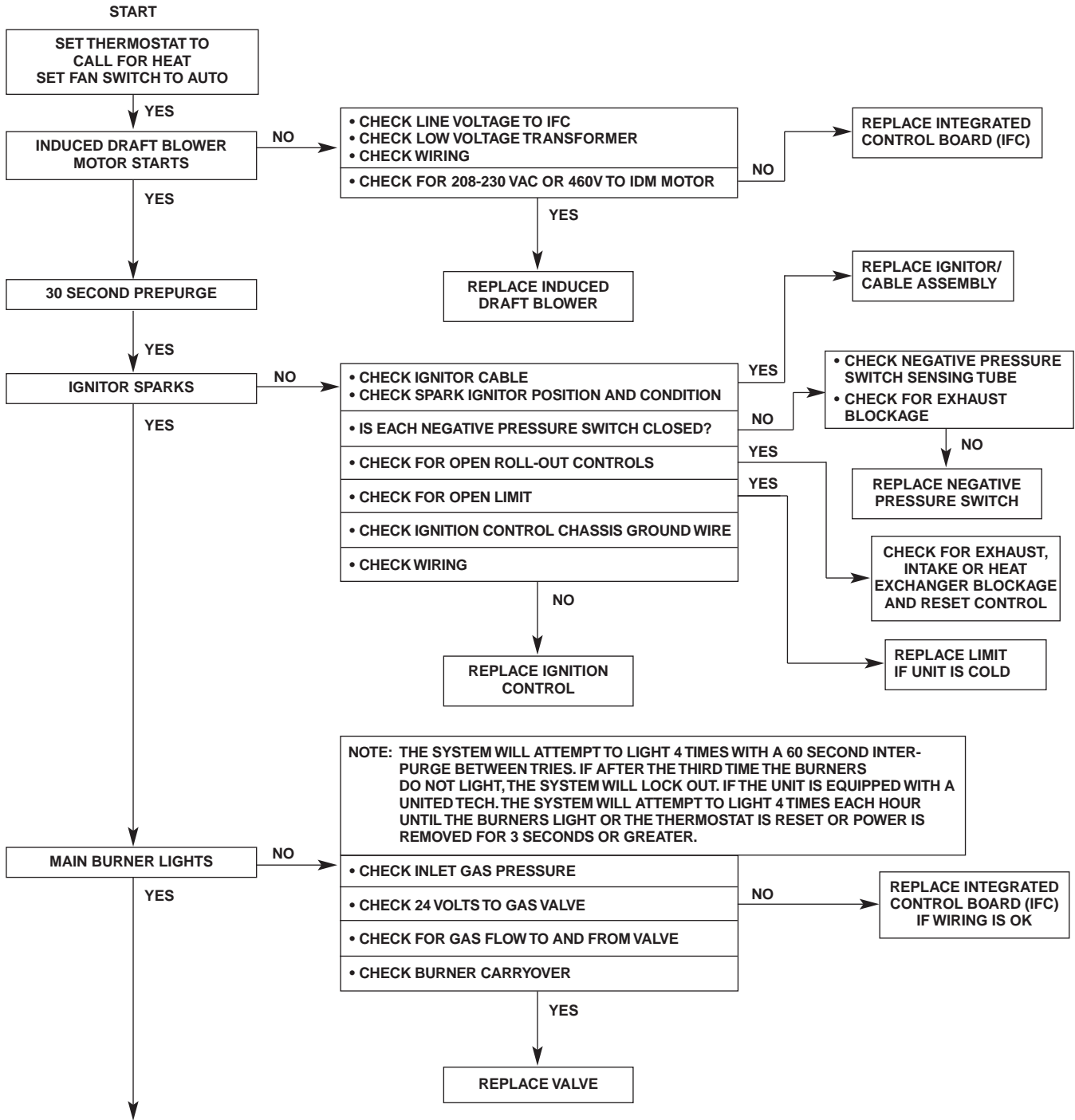

FLOW CHART CONTINUED ON NEXT PAGE



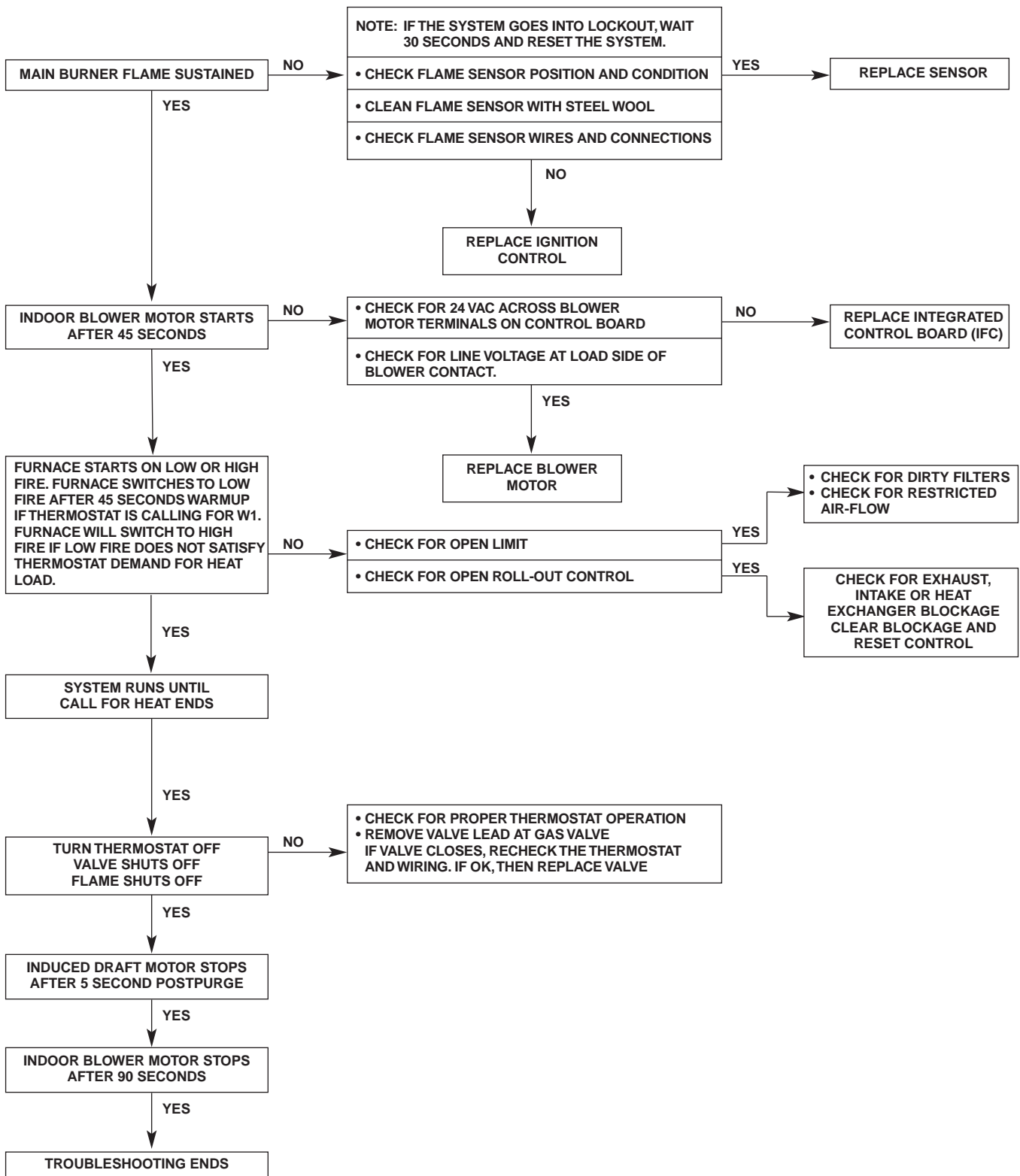

REPEAT PROCEDURE UNTIL TROUBLE FREE OPERATION IS OBTAINED.

FIGURE 21

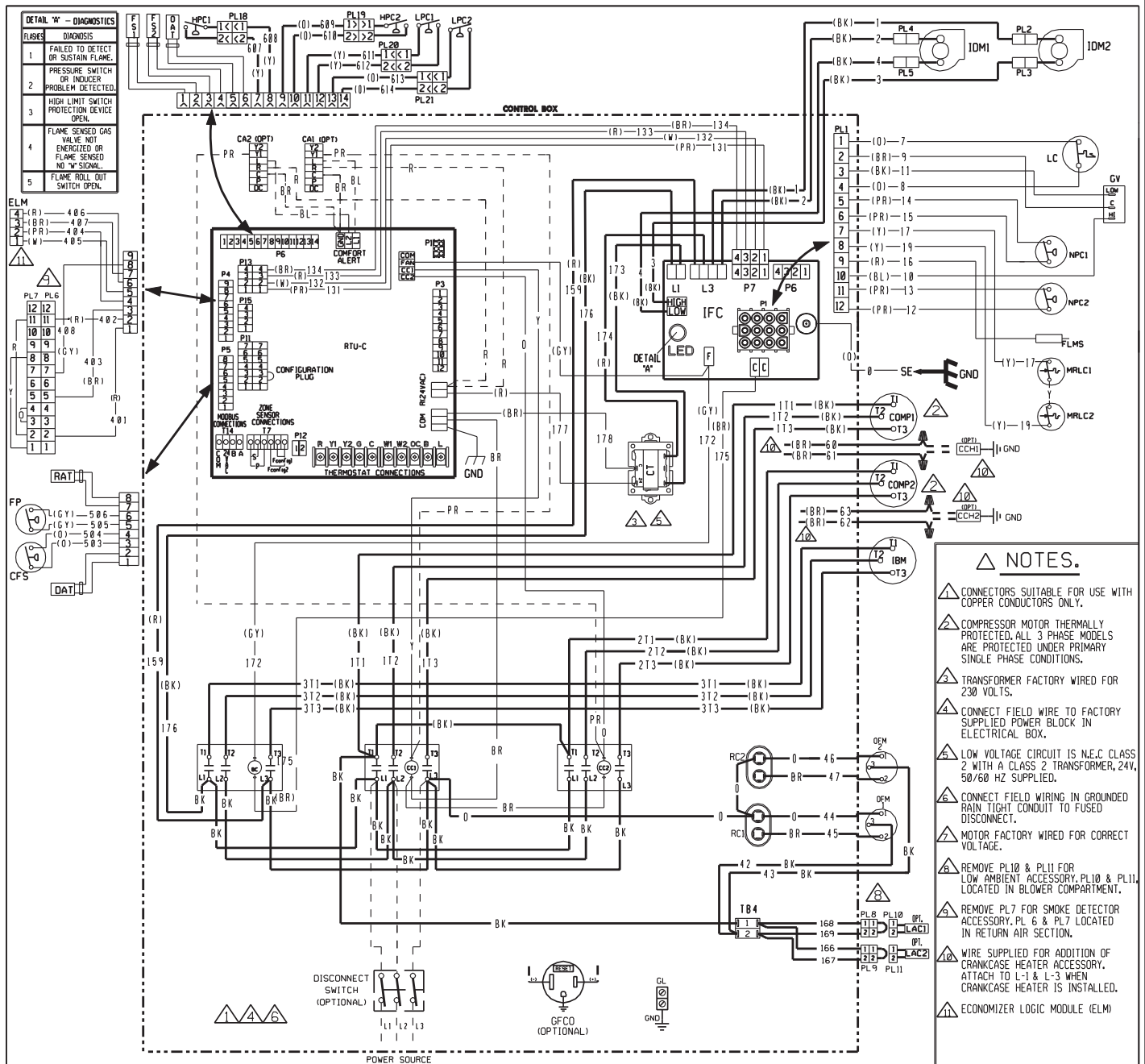

**COMPONENT CODE**

BC	BLOWER CONTACTOR	IDM	INDUCED DRAFT MOTOR
CA	COMFORT ALERT MODULE	IFC	INTEGRATED FURNACE CONTROL
CC	COMPRESSOR CONTACTOR	LAC	LOW AMBIENT COOLING CONTROL
CCH	CRANKCASE HEATER	LPC	LOW PRESSURE CONTROL
CFS	CLOGGED FILTER SWITCH	MRLC	MANUAL RESET LIMIT CONTROL
COMP	COMPRESSOR	NPC	NEGATIVE PRESSURE CONTROL
CT	CONTROL TRANSFORMER	OAT	OUTSIDE AIR SENSOR
DISC	DISCONNECT SWITCH	OFM	OUTDOOR FAN MOTOR
FLMS	FLAME SENSOR	PLUG	POWER TRANSFORMER
FP	FAN FROVING	RAT	RETURN AIR SENSOR
FS	FREEZE SENSOR	RC	RUN CAPACITOR
GFCD	GROUND FAULT CONVENIENCE OUTLET	RTU-C	ROOFTOP UNIT CONTROL
GL	GROUND LUG	SE	SPARK ELECTRODE
GND	GROUND	TB	TERMINAL BLOCK
GV	GAS VALVE	TB	TERMINAL BLOCK
HPC	HIGH PRESSURE CONTROL	WIRE NUT	
IBM	INDOOR BLOWER MOTOR BELT DRIVE		

**WIRING INFORMATION**

LINE VOLTAGE  
 -FACTORY STANDARD  
 -FACTORY OPTION  
 -FIELD INSTALLED

LOW VOLTAGE  
 -FACTORY STANDARD  
 -FACTORY OPTION  
 -FIELD INSTALLED

REPLACEMENT WIRE  
 -MUST BE THE SAME SIZE AND TYPE OF INSULATION AS ORIGINAL (105° C MIN.)

WARNING  
 -CABINET MUST BE PERMANENTLY GROUNDED AND CONFORM TO I.E.C., N.E.C., C.E.C., AND LOCAL CODES AS APPLICABLE.

**WIRE COLOR CODE**

BK	BLACK	O	ORANGE
BR	BROWN	PR	PURPLE
BL	BLUE	R	RED
G	GREEN	W	WHITE
GY	GRAY	Y	YELLOW

**WIRING DIAGRAM**  
 (-)K?L-C090/102/120/150/151  
 208-230/460V 3 PH, 60 HZ.  
 ROOFTOP W/RTU-C

DR. BY	APP. BY	DATE	DWG. NO.	REV
MGR		4-14-09	90-103089-02	03

FIGURE 22

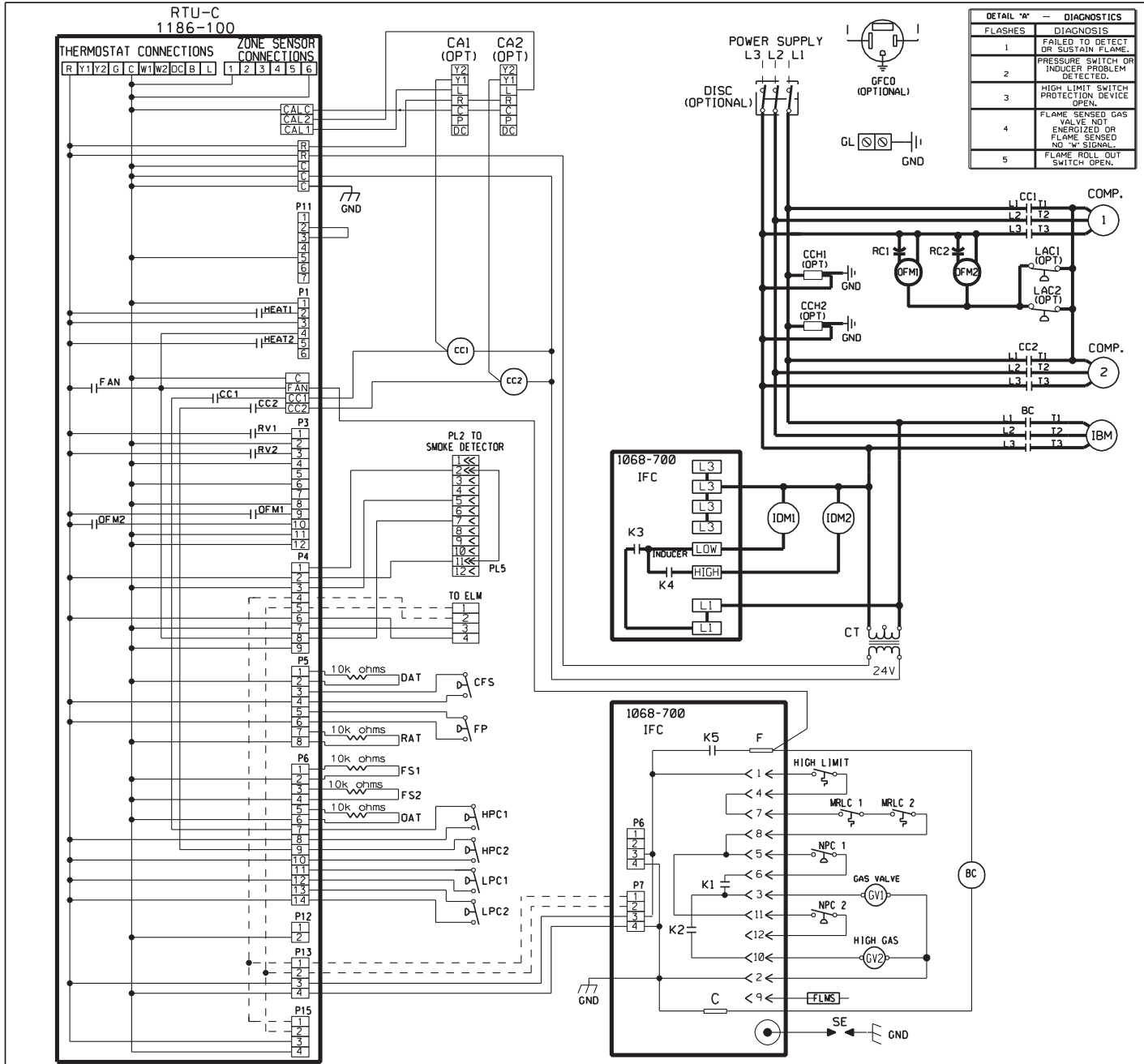

COMPONENT CODE

BC	BLOWER CONTACTOR	IDM	INDUCED DRAFT MOTOR
CA	COMFORT ALERT MODULE	IFC	INTEGRATED FURNACE CONTROL
CC	COMPRESSOR CONTACTOR	LAC	LOW AMBIENT COOLING CONTROL
CCH	CRANKCASE HEATER	LC	LIMIT CONTROL
CFS	CLOGGED FILTER SWITCH	LPC	LOW PRESSURE CONTROL
COMP	COMPRESSOR	MAS	MIX AIR SENSOR
CT	CONTROL TRANSFORMER	MRLC	MANUAL RESET LIMIT CONTROL
DISC	DISCONNECT SWITCH	NPC	NEGATIVE PRESSURE CONTROL
FLMS	FLAME SENSOR	OAT	OUTSIDE AIR SENSOR
FP	FAN PROVING	OFM	OUTDOOR FAN MOTOR
FS	FREEZE SENSOR	PL	PLUG
GFCD	GROUND FAULT CONVENIENCE OUTLET	RAT	RETURN AIR SENSOR
GL	GROUND LUG	RC	RUN CAPACITOR
GND	GROUND	SCC	SPACE COMFORT CONTROL
GV	GAS VALVE	SE	SPARK ELECTRODE
HPC	HIGH PRESSURE CONTROL	TB	TERMINAL BLOCK
IBM	INDOOR BLOWER MOTOR BELT DRIVE	WN	WIRE NUT

WIRING INFORMATION

LINE VOLTAGE  
 -FACTORY STANDARD  
 -FACTORY OPTION  
 -FIELD INSTALLED

LOW VOLTAGE  
 -FACTORY STANDARD  
 -FACTORY OPTION  
 -FIELD INSTALLED

REPLACEMENT WIRE  
 -MUST BE THE SAME SIZE AND TYPE OF INSULATION AS ORIGINAL (105° C MIN.)

WARNING  
 -CABINET MUST BE PERMANENTLY GROUNDED AND CONFORM TO I.E.C., N.E.C., C.E.C., AND LOCAL CODES AS APPLICABLE.

WIRE COLOR CODE

BK	BLACK	O	ORANGE
BR	BROWN	PR	PURPLE
BL	BLUE	R	RED
G	GREEN	W	WHITE
GY	GRAY	Y	YELLOW

WIRING SCHEMATIC

(-)?L-C090/102/120/150/151  
 208-230/460V 3 PH, 60 HZ.  
 ROOFTOP W/RTU-C

DR. BY	APP. BY	DATE	DWG. NO.	REV
MGR		7-16-09	90-103246-02	02

FIGURE 23

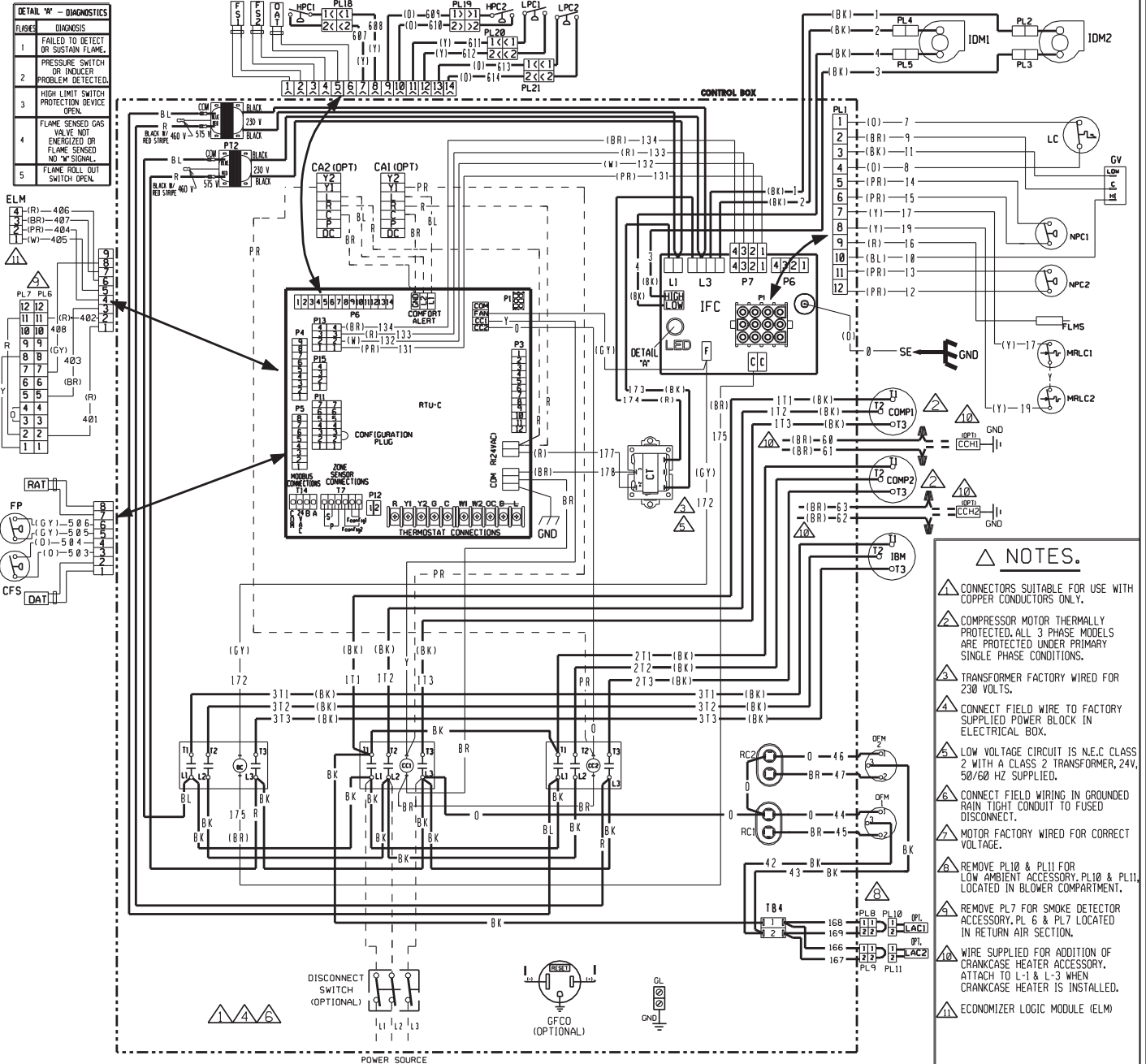

COMPONENT CODE	
BC	BLOWER CONTACTOR
CA	COMFORT ALERT MODULE
CC	COMPRESSOR CONTACTOR
CCH	CRANKCASE HEATER
CFS	CLOGGED FILTER SWITCH
COMP	COMPRESSOR
CT	CONTROL TRANSFORMER
DAT	DISCHARGE AIR SENSOR
DISC	DISCONNECT SWITCH
FLMS	FLAME SENSOR
FP	FAN PROVING
FS	FREEZE SENSOR
GFCO	GROUND FAULT CONVENIENCE OUTLET
GL	GROUND LUG
GND	GROUND
GV	GAS VALVE
HPC	HIGH PRESSURE CONTROL
IBM	INDOOR BLOWER MOTOR BELT DRIVE
IDM	INDUCED DRAFT MOTOR
IFC	INTEGRATED FURNACE CONTROL
LAC	LOW AMBIENT COOLING CONTROL
LC	LIMIT CONTROL
LPC	LOW PRESSURE CONTROL
MRLC	MANUAL RESET LIMIT CONTROL
NPC	NEGATIVE PRESSURE CONTROL
OAT	OUTSIDE AIR SENSOR
OPM	OUTDOOR FAN MOTOR
PL	PLUG
PT	POWER TRANSFORMER
RAT	RETURN AIR SENSOR
RC	RUN CAPACITOR
RTU-C	ROOFTOP UNIT CONTROL
SE	SPARK ELECTRODE
TB	TERMINAL BLOCK
W	WIRE NUT

WIRING INFORMATION	
LINE VOLTAGE	—
-FACTORY STANDARD	—
-FACTORY OPTION	- - -
-FIELD INSTALLED	---
LOW VOLTAGE	—
-FACTORY STANDARD	—
-FACTORY OPTION	- - -
-FIELD INSTALLED	---
REPLACEMENT WIRE	—
-MUST BE THE SAME SIZE AND TYPE OF INSULATION AS ORIGINAL (105° C MIN.)	
WARNING	
-CABINET MUST BE PERMANENTLY GROUNDED AND CONFORM TO I.E.C., N.E.C., C.E.C., AND LOCAL CODES AS APPLICABLE.	

WIRE COLOR CODE			
BK	BLACK	O	ORANGE
BR	BROWN	PR	PURPLE
BL	BLUE	R	RED
G	GREEN	W	WHITE
GY	GRAY	Y	YELLOW

WIRING DIAGRAM			
(-K)?L-C090/102/120/150/151			
575V 3 PH, 60 HZ.			
ROOFTOP WRTU-C			
DR. BY	APP. BY	DATE	DWG. NO.
MGR		4-14-09	90-103089-06 03
REV			

FIGURE 24

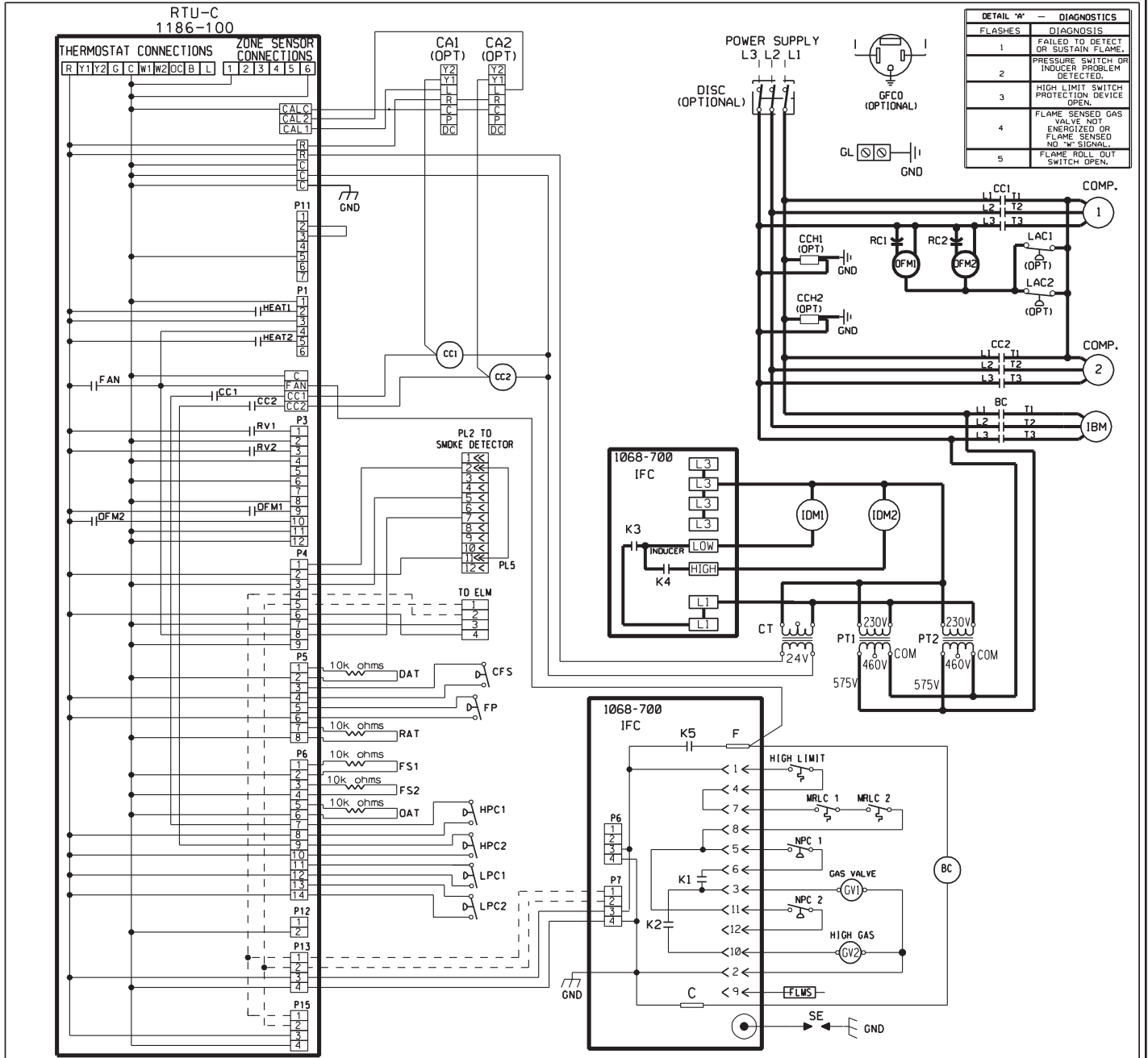

FLASHES	DIAGNOSIS
1	FAILED TO DETECT OR SUSTAIN FLAME.
2	PRESSURE SWITCH OR INDUCER PROBLEM DETECTED.
3	HIGH LIMIT SWITCH PROTECTION DEVICE OPEN.
4	FLAME SENSED GAS VALVE NOT ENERGIZED OR FLAME SENSED NO "W" SIGNAL.
5	FLAME ROLL-OUT SWITCH OPEN.

COMPONENT CODE

BC	BLOWER CONTACTOR	IDM	INDUCED DRAFT MOTOR
CA	COMFORT ALERT MODULE	IFC	INTEGRATED FURNACE CONTROL
CC	COMPRESSOR CONTACTOR	LAC	LOW AMBIENT COOLING CONTROL
CCH	CRANKCASE HEATER	LC	LIMIT CONTROL
CFS	CLOGGED FILTER SWITCH	LPC	LOW PRESSURE CONTROL
COMP	COMPRESSOR	MAS	MIX AIR SENSOR
CT	CONTROL TRANSFORMER	MRLC	MANUAL RESET LIMIT CONTROL
DISC	DISCONNECT SWITCH	NPC	NEGATIVE PRESSURE CONTROL
FLMS	FLAME SENSOR	OFM	OUTSIDE AIR SENSOR
FP	FAN PROVING	OFM	OUTDOOR FAN MOTOR
FS	FREEZE SENSOR	PL	PLUG
GFCO	GROUND FAULT CONVENIENCE OUTLET	RAT	RETURN AIR SENSOR
GL	GROUND LUG	RC	RUN CAPACITOR
GND	GROUND	SCC	SPACE COMFORT CONTROL
GV	GAS VALVE	SE	SPARK ELECTRODE
HPC	HIGH PRESSURE CONTROL	TB	TERMINAL BLOCK
IBM	INDOOR BLOWER MOTOR BELT DRIVE	W	WIRE NUT

WIRING INFORMATION

LINE VOLTAGE  
 -FACTORY STANDARD  
 -FACTORY OPTION  
 -FIELD INSTALLED

LOW VOLTAGE  
 -FACTORY STANDARD  
 -FACTORY OPTION  
 -FIELD INSTALLED

REPLACEMENT WIRE  
 -MUST BE THE SAME SIZE AND TYPE OF INSULATION AS ORIGINAL (105° C MIN.)

WARNING  
 -CABINET MUST BE PERMANENTLY GROUNDED AND CONFORM TO I.E.C., N.E.C., C.E.C., AND LOCAL CODES AS APPLICABLE.

WIRE COLOR CODE

BK	BLACK	O	ORANGE
BR	BROWN	PR	PURPLE
BL	BLUE	R	RED
G	GREEN	W	WHITE
GY	GRAY	Y	YELLOW

WIRING SCHEMATIC

(-K?L-C090/102/120/150/151  
 575V 3 PH, 60 HZ.  
 ROOFTOP W/RTU-C

DR. BY	APP. BY	DATE	DWG. NO.	REV
MGR		7-13-09	90-103246-06	02

FIGURE 25

# RKRL SYSTEM CHARGE CHARTS

## SYSTEM CHARGE CHART - REFRIGERANT 410A 7-1/2 TON, CIRCUITS 1 & 2

- CAUTION:**
1. BOTH COMPRESSORS MUST BE OPERATING BEFORE CHECKING REFRIGERANT CHARGE.
  2. RETURN AIR TEMPERATURE MUST BE WITHIN COMFORT CONDITIONS BEFORE FINAL REFRIGERANT CHECK!

- INSTRUCTIONS:**
1. MEASURE PRESSURE AT COMPRESSOR SUCTION AND LIQUID.
  2. MEASURE OUTDOOR AMBIENT TO UNIT.
  3. PLACE (X) ON CHART WHERE SUCTION AND LIQUID INTERSECT.
  4. IF (X) IS BELOW OUTDOOR AMBIENT LINE, ADD CHARGE AND REPEAT STEPS 1-3.
  5. IF (X) IS ABOVE OUTDOOR AMBIENT LINE, RECOVER EXCESS CHARGE AND REPEAT STEPS 1-3.

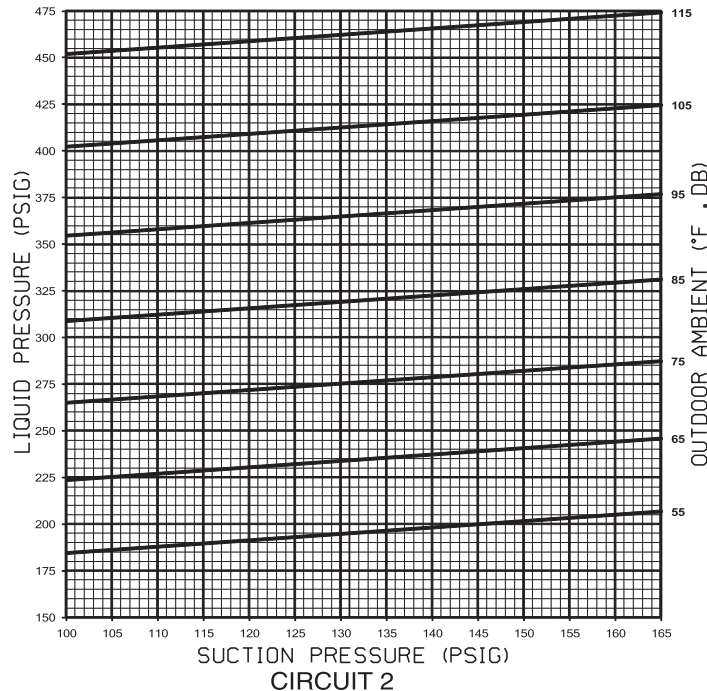
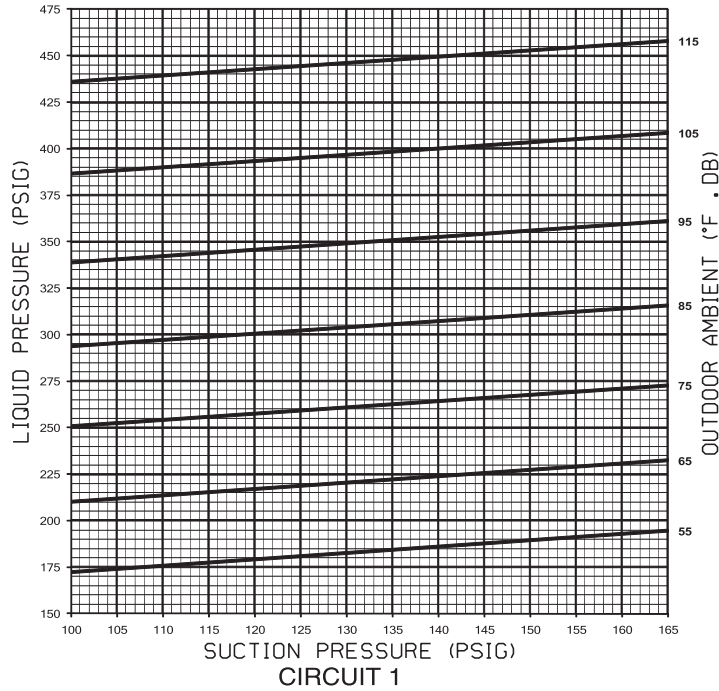

92-102259-30-00

FIGURE 26

# RKRL SYSTEM CHARGE CHARTS

## SYSTEM CHARGE CHART - REFRIGERANT 410A 10 TON, CIRCUITS 1 & 2

- CAUTION:**
1. BOTH COMPRESSORS MUST BE OPERATING BEFORE CHECKING REFRIGERANT CHARGE.
  2. RETURN AIR TEMPERATURE MUST BE WITHIN COMFORT CONDITIONS BEFORE FINAL REFRIGERANT CHECK!

- INSTRUCTIONS:**
1. MEASURE PRESSURE AT COMPRESSOR SUCTION AND LIQUID.
  2. MEASURE OUTDOOR AMBIENT TO UNIT.
  3. PLACE (X) ON CHART WHERE SUCTION AND LIQUID INTERSECT.
  4. IF (X) IS BELOW OUTDOOR AMBIENT LINE, ADD CHARGE AND REPEAT STEPS 1-3.
  5. IF (X) IS ABOVE OUTDOOR AMBIENT LINE, RECOVER EXCESS CHARGE AND REPEAT STEPS 1-3.

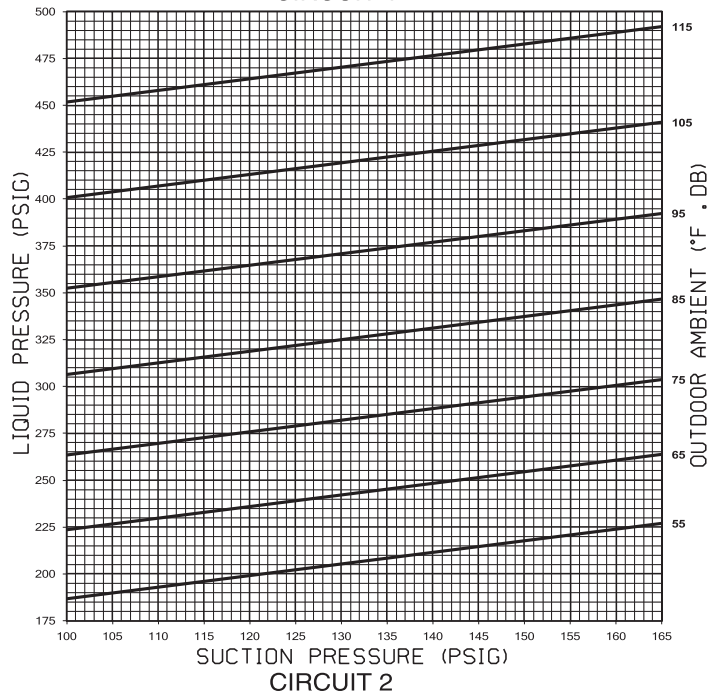
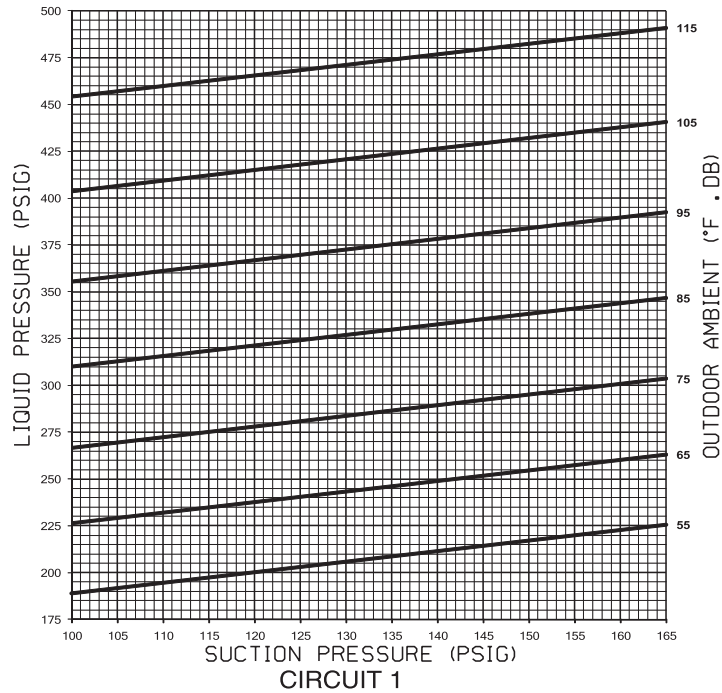

92-102259-31-00

