

# EZ-INSTALLATION GUIDE



This guide covers Rheem or Ruud Hydronic Air Handlers installed with Rheem or Ruud Tankless water heaters.

- TIPS FOR A PROPER INSTALLATION
  - SIZING INFORMATION
- SELECTING PROPER FAN SPEEDS
- INSTALLATION CONSIDERATIONS
  - BASIC REQUIREMENTS
  - COMMON QUESTIONS

This guide is designed to provide a high-level installation overview and address key installation questions. It does not supplement the installation instructions in the Use and Care Manual provided with the water heater. All instructions and installation requirements, as well as any local or national codes, must be followed.



# TYPICAL INSTALLATION

## Tankless with the RHWB Air Handler

This system is specifically designed for use with tankless water heating. The tankless water heater will provide the hot water for the system. The air handler has a built-in pump that is designed to push the necessary head and proper flow through a Rheem or Ruud brand tankless water heater.

NOTE: Proper operation cannot be guaranteed with any other brand of tankless water heater. Use with any other water heating system such as a tank or boiler is not recommended. The water heating system must also provide domestic hot water to the building, (an open system). A closed system is not permitted with the tankless water heater.

Figure 1 - Typical Air Handler and Tankless Water Heater Installation

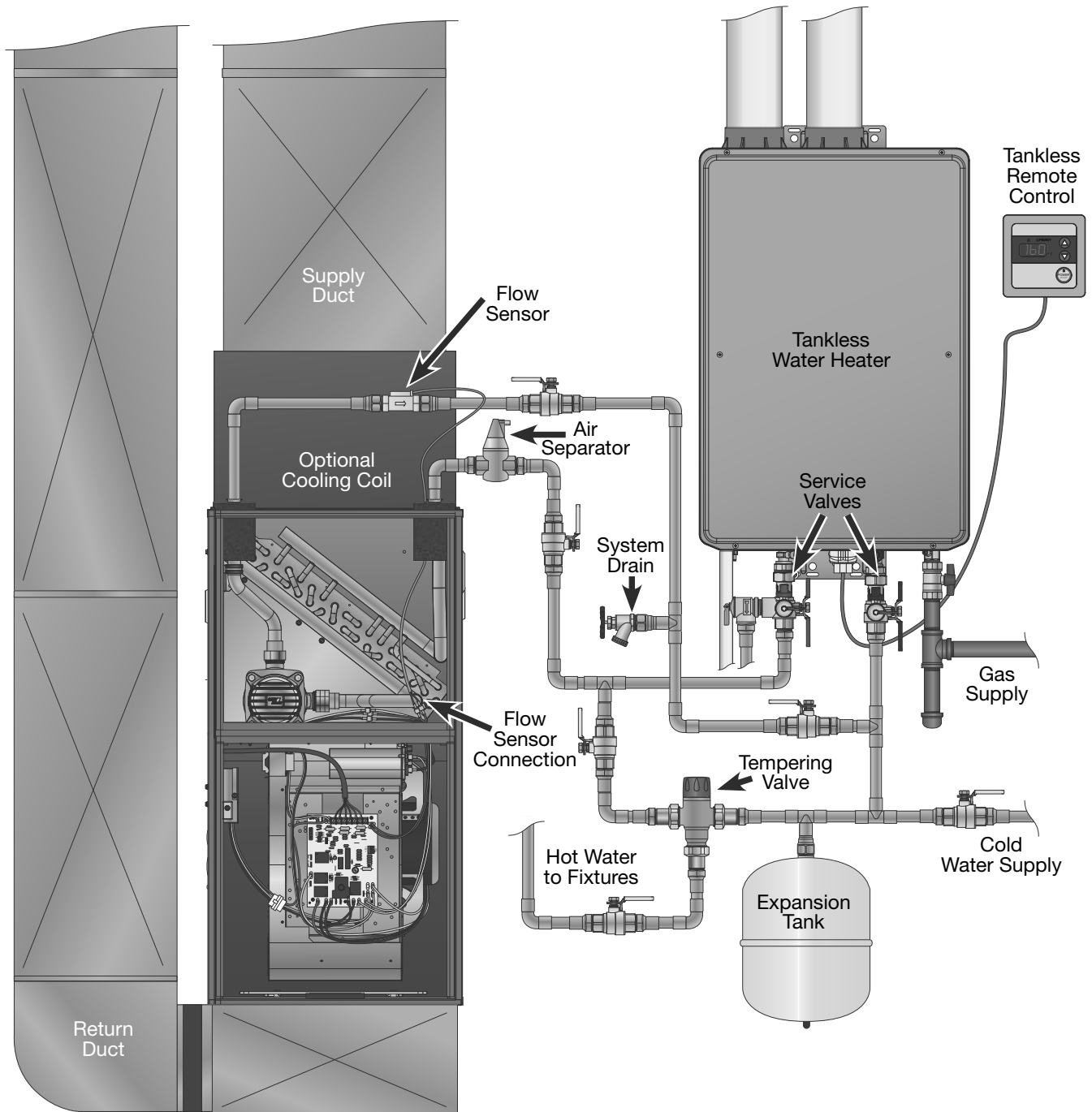

# -sizing considerations

## Tankless Water Heater Installation

The tankless water heater must be installed in accordance with the Installation Instructions listed in the Use and Care Manual provided with the tankless water heater. Review all safety guidelines and installation considerations before installing the tankless water heater.

## Tankless Water Heater Sizing

The tankless water heater must be sized properly to supply the hot water demand of the fixtures along with the hot water demand used to supply the hydronic air handler. Fill out Chart 1 for a simplified calculation to approximate the BTU/HR capacity of the tankless water heater required for the system.

Chart 1 - Tankless Sizing Calculation

Tankless System with Air Handler - Simplified Calculation Form					
Enter your average cold water temperature (Example: 45°F)				A.	
Enter the Hot Water Temperature Setting for the air handler (Example: 160°F)				B.	
Enter the Hot and Cold Water Temperature Differential, <i>Subtract (A) from (B)</i>				C.	
Enter the Tempered Hot Water Temperature for the fixtures (Example: 120°F)				D.	
Enter the Tempered and Cold Water Temperature Differential, <i>Subtract (A) from (D)</i>				E.	
Enter the Tempered Water Factor, <i>divide (E) by (C)</i>				F.	
Water Use Calculator				Complete the Water Use Calculator before proceeding to J	
Fixtures	Qty	Water Use Factor	Total (WUF X Qty)	J.	
Tub/Shower*		1.5		K.	
Garden Tub		1.0		L.	500
Lavatories		0.25		M.	
Kitchen Sink		0.5		N.	
Dishwasher		0.5		O.	
Washer		1.0		P.	
WUF Total, <i>sum above</i>			G.		
Total Household Members			H.		
Sim Use, <i>multiply (H) by 0.1</i>			I.		
* Showers are based on a typical 2.5 GPM Shower head and do not include any specialized fixtures .				** See the Hydronic Air Handler/Tankless Water Heater Performance Chart located in the Air Handler Installation and Operation Manual for the nominal BTU/HR Capacity.	
				The Total BTU/HR Capacity should be equal to or close to the value calculated in (R). Some variation is allowed for in this formula. This form should not be used to size a general hot water system alone. The values here are adjusted to consider the use with a tempered water system in conjunction with an air handler.	
				Simultaneous Use Factor,† <i>multiply (G) by (I)</i>	
				Hot Water Use Factor, <i>multiply (J) by (F)</i>	
				Heat Factor, <i>constant number (provided)</i>	
				Heat Factor Calculation, <i>multiply (L) by (C)</i>	
				Water Heating BTU Calculation, <i>multiply (M) by (K)</i>	
				Tankless Water Heater Efficiency (Example: 94% or .94)	
				Tankless BTU/HR Requirement, <i>divide (N) by (O)</i>	
				Air Handler BTU/HR Capacity**	
				Total System BTU Requirement, <i>add (P) and (Q)</i>	
				R.	

† Simultaneous use is the total number of fixtures in the home that can be used at the same time.

‡ Heat Factor Calculation is total amount of BTU/HR required to raise the water temperature by the differential

## Flow Sensor Installation

The flow sensor must be installed on the water return line going back to the tankless. It is a directional sensor and the flow arrow must point in the direction of flow back to the tankless water heater.

The sensor should be installed as close to the air handler as possible, but must be a minimum of 4 inches from any elbow, valve, or other fitting. The flow switch has two 3/4"-male threaded fittings on either side. The threads should be sealed with Teflon tape.

Use a support wrench when tightening the sensor into the pipe fitting. Do not exceed 15lb/ft torque when tightening the sensor as the plastic housing can be damaged by overtightening. **Do not solder or sweat copper fittings within 18 inches of the installed sensor.**

The sensor includes a 6 ft cord and the leads connect to the air handler. Inside the air handler, near the pump, are a set of blue and brown wires with spade terminals. Connect the blue and brown wires from the sensor to these inside the air handler.

Figure 2 - Flow Sensor

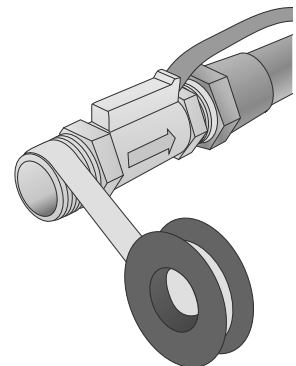

# INSTALLATION CONNECTIONS

Figure 3 - Air Handler Water Connections

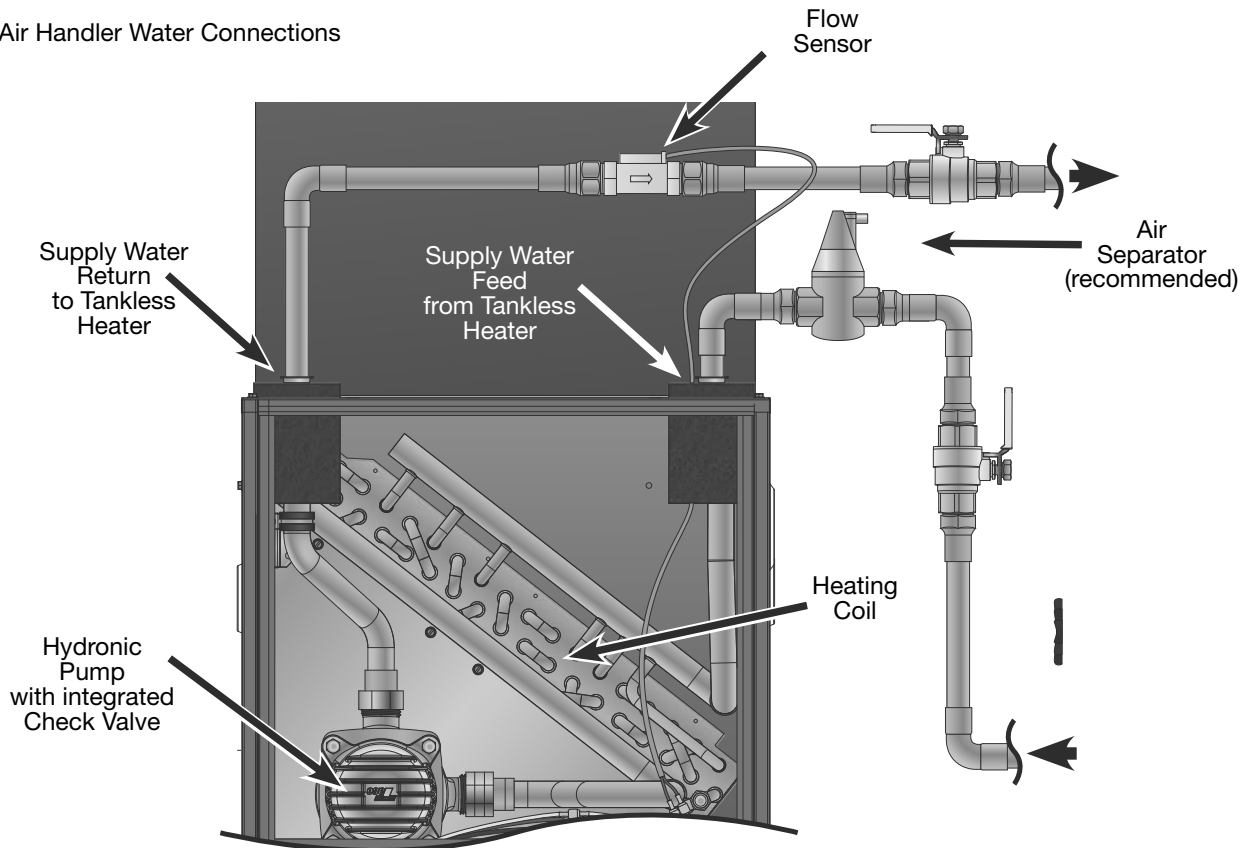

## Water Piping

The system should be plumbed with a minimum of 3/4"-rigid copper piping (CPVC and PEX can be used where codes allow). A maximum of 100 equivalent feet is permitted between the air handler and tankless water heater. For details, use the information under the "Procedure For Calculating Total Equivalent Length of Pipe" in the Installation and Operation Manual provided with the air handler.

## Air Separator (Recommended)

To keep air from building up in the system during use, it is recommended that an Air Separator, such as a Taco 4900 Series, be installed in the system between the water heater and air handler.

## Pipe Insulation

All water piping between the air handler and tankless water heater should be well insulated to prevent heat loss.

## Thermostatic Tempering Valve

When using the system with hot water settings above 120°F, we recommend that a thermostatic tempering valve, such as a Taco 5000 series, be installed to supply the fixtures in the building. Follow the manufacturer's instructions for the installation of the tempering valve.

## Thermal Expansion

An expansion tank should be installed on the plumbing system when using this air handler. When water is heated, it expands. This expansion can cause the pressure in the plumbing to increase and potentially damage faucets and fixtures. A properly installed expansion tank will prevent this unsafe build-up of pressure. Follow the manufacturer's instructions for installing the expansion tank.

Figure 4 - Tempering Valve and Expansion Tank

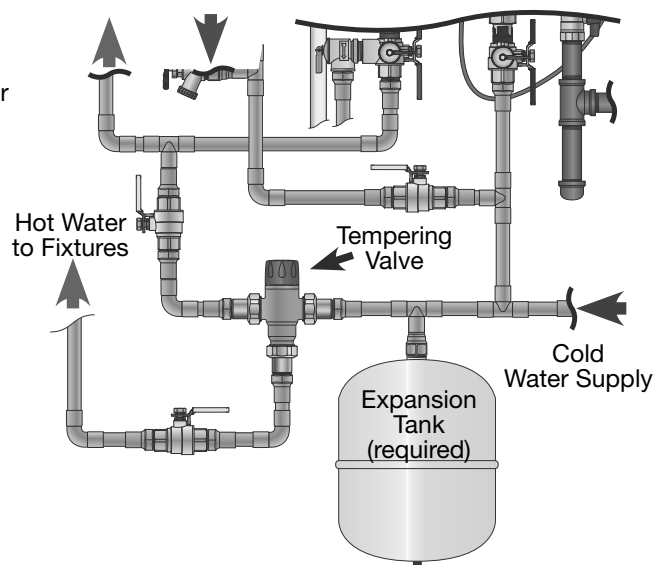

# INSTALLATION CONNECTIONS

## Service Valves

We recommend the installation of tankless service valves with your tankless water heater. Service valves provide a quick and easy method to service and flush your tankless water heater.

## Gas Supply

Most tankless water heaters require a minimum of a ¾" gas supply line. Gas supply is critical to the proper operation of the tankless water heater and system. An improperly sized and/or installed gas supply system can cause operational problems with the tankless water heater, and result in the loss of air handler provided heating for the building. Consult the installation instructions provided with the tankless water heater regarding gas pipe sizing and installation.

## Venting

The tankless water heater is designed to be vented outdoors. Direct vent style models require the combustion air be drawn from the outdoors. Follow all venting requirements as outlined in the installation instructions provided with your tankless water heater.

## Tankless Remote Control

Rheem and Ruud tankless water heaters are provided with a remote display and control. It is recommended that this remote be installed where the owner can easily access it. The remote will not only allow the water temperature to be adjusted but, will notify the owner of any operating issues.

## Tankless Water Heater Temperature Adjustment

The Rheem and Ruud Tankless water heaters can only operate up to a maximum of 140°F as configured from the factory. In most applications the air handler will need water temperatures of 150°F to 160°F to provide the maximum heating capacity for your comfort. A "Temperature Upgrade Kit for Commercial and Hydronic Heating" is available from Rheem. This temperature upgrade kit will adjust the programming in the computer for the tankless water heater and allow a maximum temperature setting of up to 185°F. Each upgrade kit is made for a specific tankless model. Consult with your distributor or Rheem Technical Service to determine the proper temperature upgrade kit for your specific Rheem or Ruud tankless water heater.

Figure 5 - Tankless Water Heater

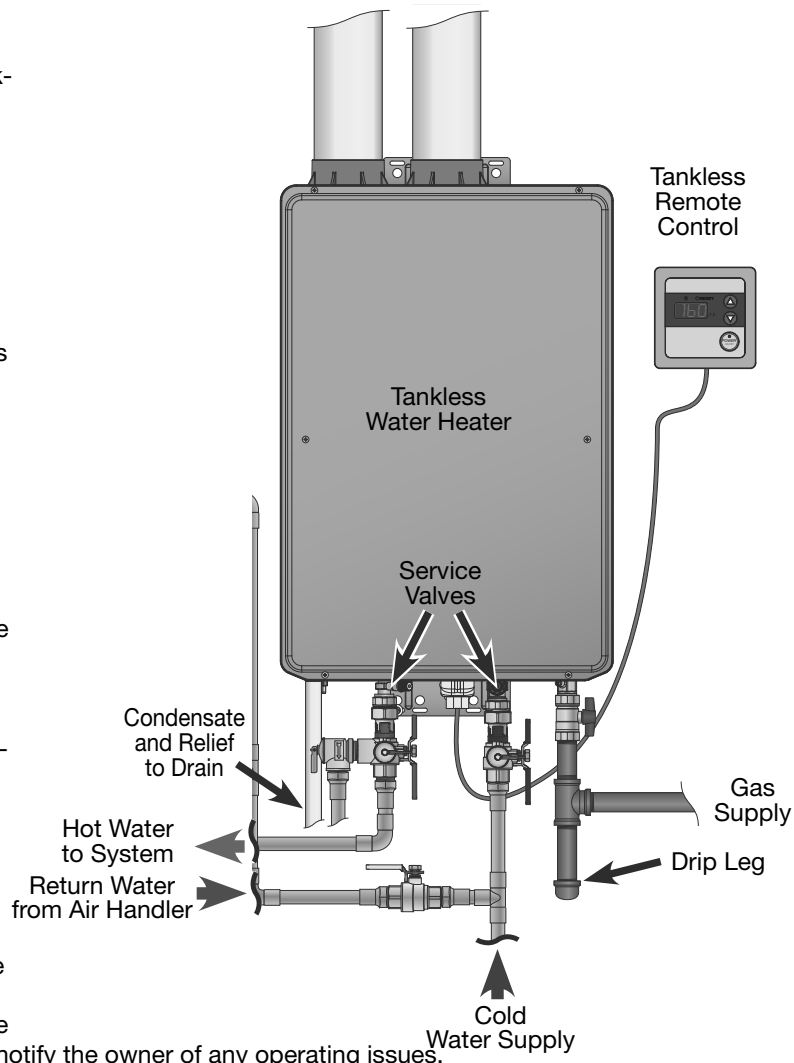

# AIRFLOW ADJUSTMENTS - COOLING

## Airflow Application, Adjustments, and Measurements

This guide provides the basic information about how to configure the system to deliver proper airflow to allow for adequate comfort and quiet operation of the Air Handler system. In order to accomplish this, the proper fan speed must be selected. This section will provide information on proper airflow selection, adjustment, and measurement methods.

## Load Requirements and Ductwork Application

Before installing the new RHWB Hydronic Air Handler, the load requirements must be accounted for and the ductwork system properly designed. **NOTE: A licensed HVAC technician must install this equipment.** For heat gain/loss requirements, reference the HVAC industry standard, ACCA Manual J. For proper ductwork design, reference HVAC industry standard, ACCA Manual D. Failure to design to these standards will result in poor system performance, noisy operation, inadequate airflow, or poor heating and cooling. An improperly installed system could void the warranty.

## Proper Airflow Selection Requirements

The following sections provide the basics to determine the proper airflow for the system, and to illustrate where the motor speed taps need to be placed. The first step in this process is to determine what the proper airflow should be depending on the type of equipment that is being installed. For example, this calculation will show the installer how to determine the proper airflow for an RHWB-04WMX36A air handler matched with a 14AJM25 outdoor condensing unit and a RCFL-H\*2417 evaporator.

NOTE: The following information is for the combinations aforementioned and provided for example only. Typical air flow for indoor/outdoor combinations range from 350 to 450 CFM per ton. Combinations of other equipment will be different from what is shown in these examples. See applicable instructions for details.

## Cooling Airflow Calculations

Finding the rated airflow for the 14AJM25 condensing unit can be done by locating the condensing unit's airflow addendum, which is provided with the condensing unit. See Chart 2 for a sample of what the addendum will contain.

Chart 2 - Sample Addendum

Model Numbers		
Outdoor Unit 14A*M	Indoor Coil and/or Air Handler	Indoor CFM [L/s]
25	RCFL-H*2417(RGTM-06?MAE?)	750 [354]
	RCFL-H*2417(RHWB-04WMX36A)	825 [389]
	RCFL-H*2417(RHWA-070E03)	800 [378]

Rated Air Flow

The cooling airflow performance is based on the total system static pressure downstream from the air handler.

With our example coil, the total system static would be 0.23" (wet evaporator coil), plus 0.20" for the Static Duct Pressure, plus 0.08" for the Internal Air Filter, and plus 0.08" for an External Air Filter, giving a total of 0.59" w.c. in system pressure. Referenced in Chart 3 is the wet evaporator coil pressure drop for our example RCFL-H\*2417 coil. This sample is from the air flow chart located in the Installation and Owners Manual of the indoor evaporator and shows the pressure drop across the coil for a given CFM of air flow. The Static Duct Pressure comes from the measurements described later in this instruction, the air filter numbers are based on common air filters.

Chart 3 - Static Pressure Drop Chart

Coil Model	Approx. Design Air Flow CFM [L/S] range	Face Area Sq.ft. [m <sup>2</sup> ]	Fins-In/Rows Deep	Static Pressure Drop Through Wet Cooling Coil [kPa] (Inches W.C.) CFM [L/S]													
				600 [283]	700 [330]	800 [378]	900 [425]	1000 [472]	1100 [519]	1200 [566]	1300 [614]	1400 [661]	1500 [708]	1600 [755]	1700 [802]	1800 [850]	1900 [897]
HIGH EFFICIENCY COOLING COILS																	
2414	600/1000 [283/472]	4.56 (0.42)	16/2	.17 (.043)	.21 (.053)	.25 (.063)	.31 (.080)	.40 (.100)	.46 (.117)	—	—	—	—	—	—	—	—
2417	600/1000 [283/472]	4.56 (0.42)	16/2	.15 (.039)	.19 (.049)	.23 (.059)	.30 (.076)	.38 (.096)	.45 (.117)	—	—	—	—	—	—	—	—
2617 /3617	900/1400 [424/661]	5.70 (0.53)	16/2	—	—	.17 (.043)	.21 (.053)	.26 (.064)	.31 (.076)	—	—	—	—	—	—	—	—
	900/1400 [424/661]	5.70 (0.53)	16/2	—	—	.15 (.039)	.18 (.046)	.21 (.053)	.26 (.064)	—	—	—	—	—	—	—	—

Pressure Drop for cooling at 800 CFM

NOTE: Represents Coil-Only Airflow Ratings  
[ ] Designated Metric Conversion

# AIRFLOW ADJUSTMENTS - HEATING

Chart 4 shows that the tap closest for the initial startup would be the “Medium-Low” tap (total static = 0.59”). Reference the section called “Control Board and Speed Taps” for instructions on how to adjust the speed taps for the motor.

Chart 4 - Hydronic Air Handler Air Flow and Pressure Chart

Model	Blower / Motor HP Inches [mm]	Speed	CFM [L/S] Air Delivery External Static Pressure inches Water column [kPa]									
			0.1 [.02]	0.2 [.05]	0.3 [.07]	0.4 [.07]	0.5 [.12]	0.6 [.15]	0.7 [.17]	0.8 [.19]	0.9 [.22]	1.0 [.24]
RHWB-04WMP36A	11 X 7 [279 X 178]/ 1/2 [373]	Low	794 [375]	775 [366]	749 [353]	719 [339]	686 [324]	655 [309]	621 [293]	590 [278]	534 [252]	473 [223]
		M-Lo	895 [409]	865 [400]	822 [379]	777 [361]	722 [340]	655 [423]	621 [408]	590 [457]	534 [437]	473 [420]
		M-Hi	1202 [567]	1176 [555]	1160 [547]	1100 [519]	1073 [506]	1047 [494]	1008 [476]	969 [457]	926 [437]	890 [420]
		High	1356 [640]	1336 [631]	1301 [614]	1266 [597]	1222 [579]	1177 [561]	1132 [543]	1087 [525]	1042 [507]	997 [489]

Airflow = 895 CFM at .6” W.c. Static Pressure

## Heating Airflow Calculations

This section will outline how to select the proper heating speed tap for the Hydronic Air Handler using the same combination of factors that was used for the cooling selection section.

The Installation and Owners Manual for the RHWB lists the rated airflow for heating. Take note that the heating performance is based on 160°F water temperature supplied by the tankless water heater and 68°F ambient air temperature. The maximum exiting water temperature is limited to 140°F. Chart 5 is an example of the chart that is listed in the Installation and Owners Manual for performance.

Chart 5 - Hydronic Air Handler Performance Chart

SAMPLE HYDRONIC AIR HANDLER PERFORMANCE									
Air Handler Model Number	Water Inlet Temp (°F) [°C]	Water Outlet Temp (°F) [°C]	Water Flow		Air Inlet Temp (°F) [°C]	Air Outlet Temp (°F) [°C]	Air Cfm [L/S]	Capacity (Btu/Hr) [Kw]	Air Temp Rise (°F) [°C]
			Lb/Hr	GPM					
RHWB-04WMP36A RHWB-04WMX36A	120 [49]	110 [43]	[kg/hr] 2000/ [907]	4	68 [20]	106 [41]	20900 [6.13]	30 [17]	
	130 [54]	117 [47]				113 [45]	25800 [7.56]	37 [21]	
	140 [60]	125 [52]				122 [50]	29800 [8.73]	43 [24]	
	150 [66]	132 [56]				130 [54]	35000 [10.26]	50 [28]	
	160 [71]	140 [60]				137 [58]	40000 [11.72]	57 [32]	

Heating Rated CFM

Chart 5 shows that at 646 CFM with the given conditions, the unit will provide for a 57°F air temperature rise. If the CFM is higher, the unit will produce a smaller air temperature rise and higher outlet water temperature. If the CFM is lower, it will produce a higher air temperature rise and lower outlet water temperature. Since the outlet water temperature must be limited as water returns to the tankless water heater and the air temperature rise is important for comfort, a balance has to be achieved during the installation of the system.

Chart 6 - Static Pressure Drop Chart

Coil Model	Approx. Design Air Flow CFM [L/S] range	Face Area Sq.ft. [m2]	Fins-In/Rows Deep	Static Pressure Drop Through Wet Cooling Coil [kPa] (Inches W.C.) CFM [L/S]													
				600 [283]	700 [330]	800 [378]	900 [425]	1000 [472]	1100 [519]	1200 [566]	1300 [614]	1400 [661]	1500 [708]	1600 [755]	1700 [802]	1800 [850]	1900 [897]
HIGH EFFICIENCY COOLING COILS																	
2414	600/1000 [283/472]	4.56 (0.42)	16/2	.17 (.043)	.21 (.053)	.25 (.063)	.31 (.080)	.40 (.100)	.46 (.117)	—	—	—	—	—	—	—	—
2417	600/1000 [283/472]	4.56 (0.42)	16/2	.15 (.039)	.19 (.049)	.23 (.059)	.30 (.076)	.38 (.096)	.45 (.117)	—	—	—	—	—	—	—	—
2617 /3617	900/1400 [424/661]	5.70 (0.53)	16/2	—	—	.17 (.043)	.21 (.059)	.26 (.064)	.31 (.076)	—	—	—	—	—	—	—	—
	900/1400 [424/661]	5.70 (0.53)	16/2	—	—	.15 (.039)	.18 (.046)	—	—	—	—	—	—	—	—	—	—

646 CFM assume 0.17” pressure drop

NOTE: Represents Coil-Only Airflow Ratings  
[ ] Designated Metric Conversion

# AIR FLOW ADJUSTMENTS - HEATING

The coil only pressure drop chart for air handlers airflow versus the static pressure chart is used to determine the starting point prior to startup. Similar to the cooling speed tap selection (see chart 3) add up the total estimated static external to the air handler, 0.17" Coil Pressure Drop, plus 0.20" Duct Static Pressure, plus 0.08" Internal Air Filter, and plus 0.08" for an External Air Filter for a total 0.53" w.c. pressure drop. Charts 6 and 7 show the pressure drop across the coil at 646 CFM and which speed tap matches up to the required CFM. Based on this information in the example, the charts show that the proper speed tap selection would be "Low" for the RHWB Hydronic Air Handler.

Chart 7 - Hydronic Air Handler Air Flow and Pressure Chart

Model	Blower / Motor HP Inches [mm]	CFM [L/S] Air Delivery External Static Pressure inches Water column [kPa]										
		Speed	0.1 [0.2]	0.2 [0.5]	0.3 [0.7]	0.4 [0.7]	0.5 [1.2]	0.6 [1.5]	0.7 [1.7]	0.8 [1.9]	0.9 [2.2]	1.0 [2.4]
RHWB-04WMP36A	11 X 7 [279 X 178] 1/2 [373]	Low	744 [375]	775 [386]	748 [368]	710 [350]	686 [324]	655 [309]	621 [293]	590 [278]	534 [252]	473 [223]
		M-Lo	1036 [489]	1024 [483]	1002 [473]	977 [461]	922 [435]	895 [423]	865 [408]	826 [390]	761 [359]	689 [325]
		M-Hi	1202 [567]	1176 [555]	1160 [547]	1100 [519]	1073 [506]	1047 [494]	1008 [476]	969 [457]	926 [437]	890 [420]
		High	1356 [640]	1336 [631]	1301 [614]	1266 [597]	1235 [583]	1202 [567]	1156 [546]	1093 [516]	1030 [486]	959 [453]

Airflow = 686 CFM at 0.5" w.c. static pressure

Figure 6 - Hydronic Air Handler Control Board

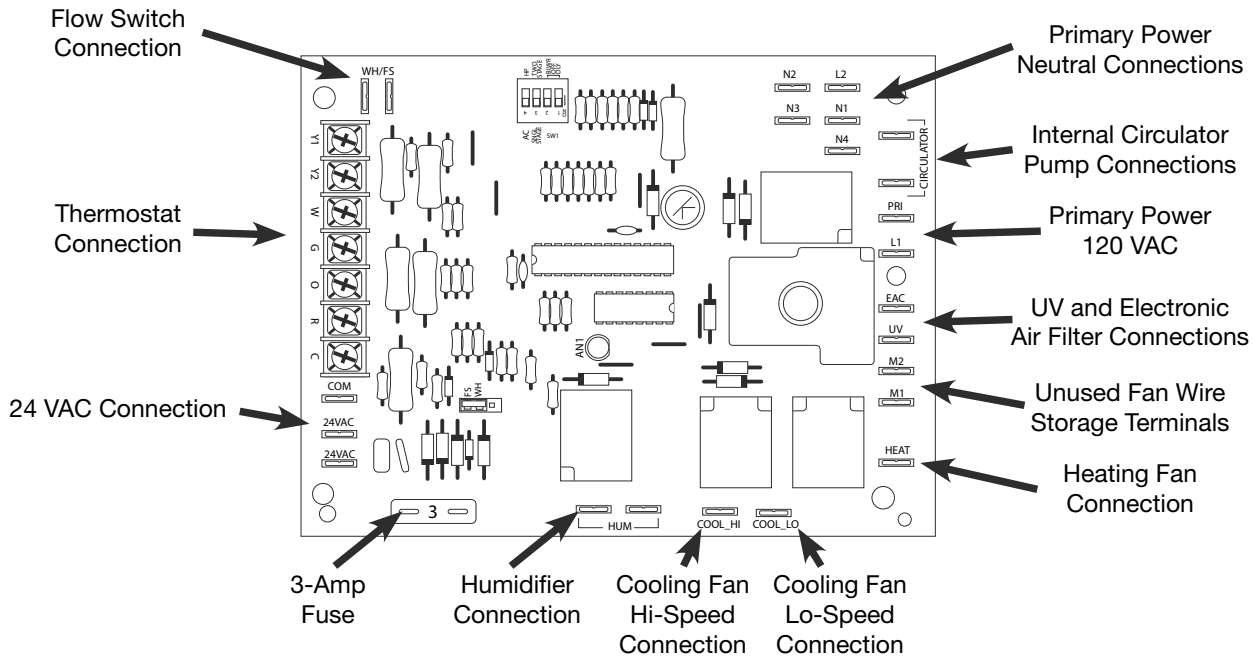
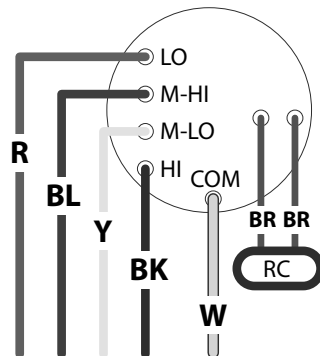

Figure 7 - Hydronic Air Handler Motor Wire Colors

## Wire Colors

- R = Red
- BL = Blue
- Y = Yellow
- BK = Black
- W = White
- BR = Brown
- G = Green
- RC = Capacitor

## PSC Motor



## Eco-Tech Motor

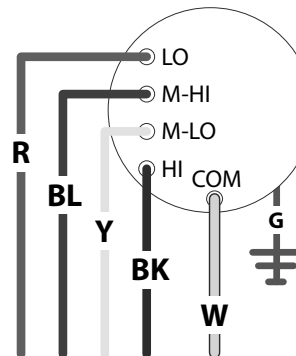



# FAN SPEED TAP CONNECTIONS

## Control Board and Speed Taps

The previous sections explained the proper starting point for airflow of the RHWB Hydronic Air Handler. This section will address how to adjust the airflow through the units control board of the unit with the motor speed taps for both the Eco-Tech and PSC versions. **NOTE: All power to the unit must be disconnected prior to adjusting any airflow.**

**WARNING! Failure to disconnect power during the adjustment could result in serious injury including death.**

Figure 6 is an illustration of the RHWB Hydronic Air Handler control board located on the blower assembly of the unit. The air handler unit is typically shipped from the factory with the cooling speed set at medium high and the heating speed set at low. Using the previous examples to figure out the starting point of the application, the cooling speed tap and heating speed tap will need to be changed to the new recommended settings. This is accomplished by swapping the appropriately colored wires to the cooling and heating taps, and storing the unused wires on the storage taps.

Figure 7 shows which colors go to which speed tap on each of the motor types available in the air handler.

As in Figure 8, carefully grasp the wire at the connector, wiggle and pull the connector from the tap on the board. **Do Not pull on the wire itself.** Connect the appropriately colored wire for the required fan speed by pushing it down on to the cooling or heating taps. Ensure the connector is fully seated down on the tap. Store any remaining wires on the M1 or M2 taps.

NOTE: In some cases the heating and cooling speed taps will need to be the same. In these cases, a jumper wire can be installed between the cooling fan and heat connections using the Rheem part number AS-50205-05-1D.

## Room Thermostat

Connect the wires for the room thermostat to the control board. The colors of the wires should match the letters on the board. Not all wire connections points may be used; It depends upon the system configuration and type of room thermostat used. Consult the Installation and Owners Manual as well as the Room Thermostat Manufacturer's Instructions for details.

Figure 9 - Room Thermostat Connection

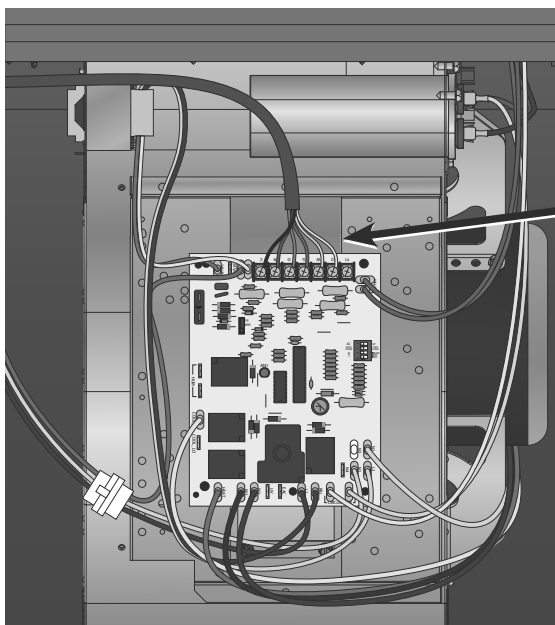
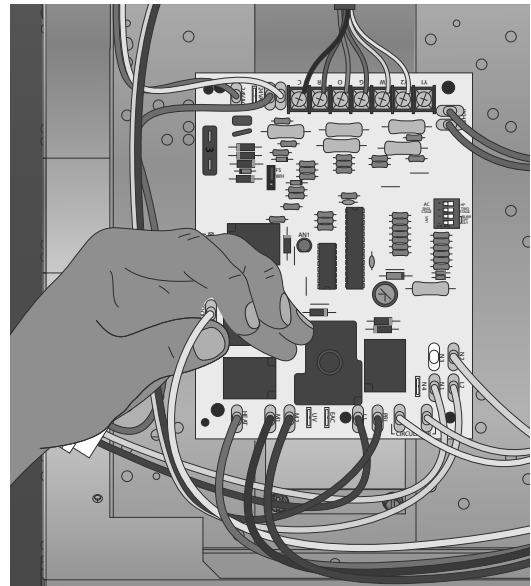

Figure 8 - Connecting Fan Speed wires



# AIRFLOW VERIFICATION

## Airflow Verification

After the system has been installed, it is important to verify the air handler is providing the proper airflow for optimum comfort. There are many different HVAC standard ways to accomplish this verification. This section will outline two common methods to calculate airflow; (1) measuring external static pressure, (2) using a flow hood.

### External Static Pressure (ESP)

A common way of measuring the airflow of the system is to measure the external duct static of the system. The recommended way of doing this is to use a device called a Magnehelic Gauge (illustrated in Figure 10).

In order to measure duct static, the pressure reading should come from the supply side past the coil and the return side downstream of the filter. Therefore, Duct Static = ESP Supply – ESP Return.

The previous section mentioned that the airflow charts shown in the Installation and Operation Manual do not include the pressure drop of the coil. Therefore, that must be added to the duct static and compared to the airflow chart. It is important to note that the air handler is not designed to handle ESP of more the 1" w.c. and less than 0.1" w.c. external to the air handler, not including the coil.

For purpose of demonstration, let's assume that when duct static was measured after initial startup the reading was 0.5" w.c. From here you would add that to the pressure drop of the coil which is 0.23" w.c. Therefore, the total static external to the air handler is 0.73" as illustrated in Chart 8.

Figure 10 - Magnehelic Gauge Pressure Test

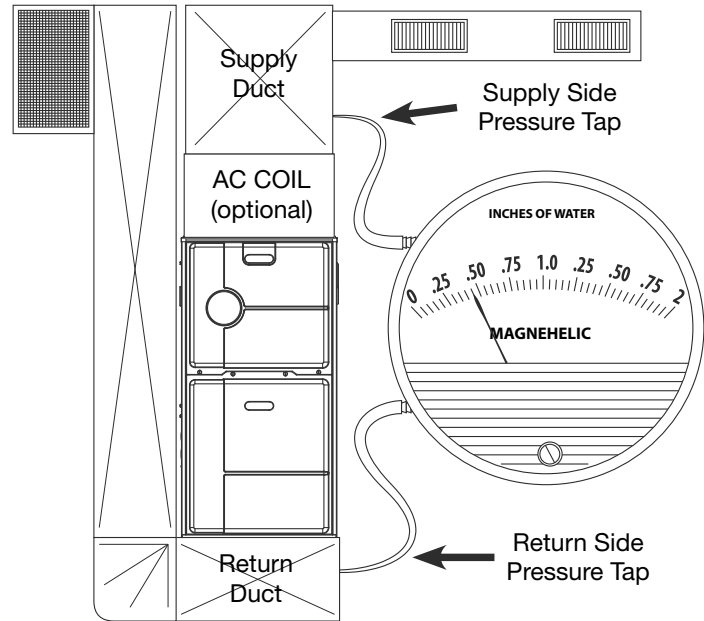

Chart 8 - Hydronic Air Handler Air Flow and Pressure Chart

Model	Blower / Motor HP Inches [mm]	CFM [L/S] Air Delivery External Static Pressure inches Water column [kPa]										
		Speed	0.1 [.02]	0.2 [.05]	0.3 [.07]	0.4 [.07]	0.5 [.12]	0.6 [.15]	0.7 [.17]	0.8 [.19]	0.9 [.22]	1.0 [.24]
RHWB-04WMP36A	11 X 7 [279 X 178]/ 1/2 [373]	Low	794 [375]	775 [366]	749 [353]	719 [339]	686 [324]	655 [309]	621 [293]	590 [278]	534 [252]	473 [223]
		M-Lo	826 [390]	865 [408]	1002 [473]	1077 [461]	1129 [495]	1181 [529]	1233 [563]	1285 [597]	1336 [631]	1388 [665]
		M-Hi	1202 [567]	1176 [555]	1160 [547]	1100 [511]	1073 [506]	1047 [491]	1008 [476]	969 [457]	926 [437]	890 [420]
		High	1356 [640]	1336 [631]	1301 [614]	1266 [597]	1235 [583]	1202 [567]	1156 [546]	1093 [516]	1030 [486]	959 [453]

Coil ESP

Duct Static 0.5"

Total Static 0.73" = 865 CFM on M-lo Tap

## Flow Hood Method

The most accurate way to measure airflow is to use a flow hood. For this device it is important to follow that manufacturer's instructions to ensure accuracy. **IMPORTANT NOTE:** Ensure a measurement is taken at each return inlet for the system. Add each of the measurements together to obtain the total air flow.

# AIR HANDLER INSTALLATION

## Flow Direction

The RHWB Hydronic Air Handler may be installed in either left- or right-side flow, upflow, or downflow configurations. When installing in a side or downflow installations, access for the plumbing connections at the top of the unit must be provided. The unit may sit directly on a plenum when installed in a down flow configuration; however, provisions should be made so the plumbing pipes are accessible for installation and service.

**NOTE: Do Not modify the internal plumbing of the RHWB Hydronic Air Handler.**

## Installation with a Heat Source Other than a Rheem Tankless Gas Water Heater

The RHWB Hydronic Air Handler is designed to be specifically installed with a Rheem or Ruud tankless gas water heater. Installation with any other water heating equipment, tanks, or boilers is not recommended. The pump in the RHWB Hydronic Air Handler is designed with a high-head pressure to accommodate the head loss of the tankless water heater and maintain a proper flow rate of around 3 GPM, depending on the specific RHWB model. If this hydronic air handler is installed with any other water heating system, other than a Rheem tankless water heater, a quality water flow control valve must be installed to limit the water flow rate through the hydronic air handler. This flow rate must not exceed than 3 GPM. Water flow rates exceeding 3 GPM will damage the air handlers heating coil and void the warranty.

Figure 11 - RHWB Dimensions and Clearances

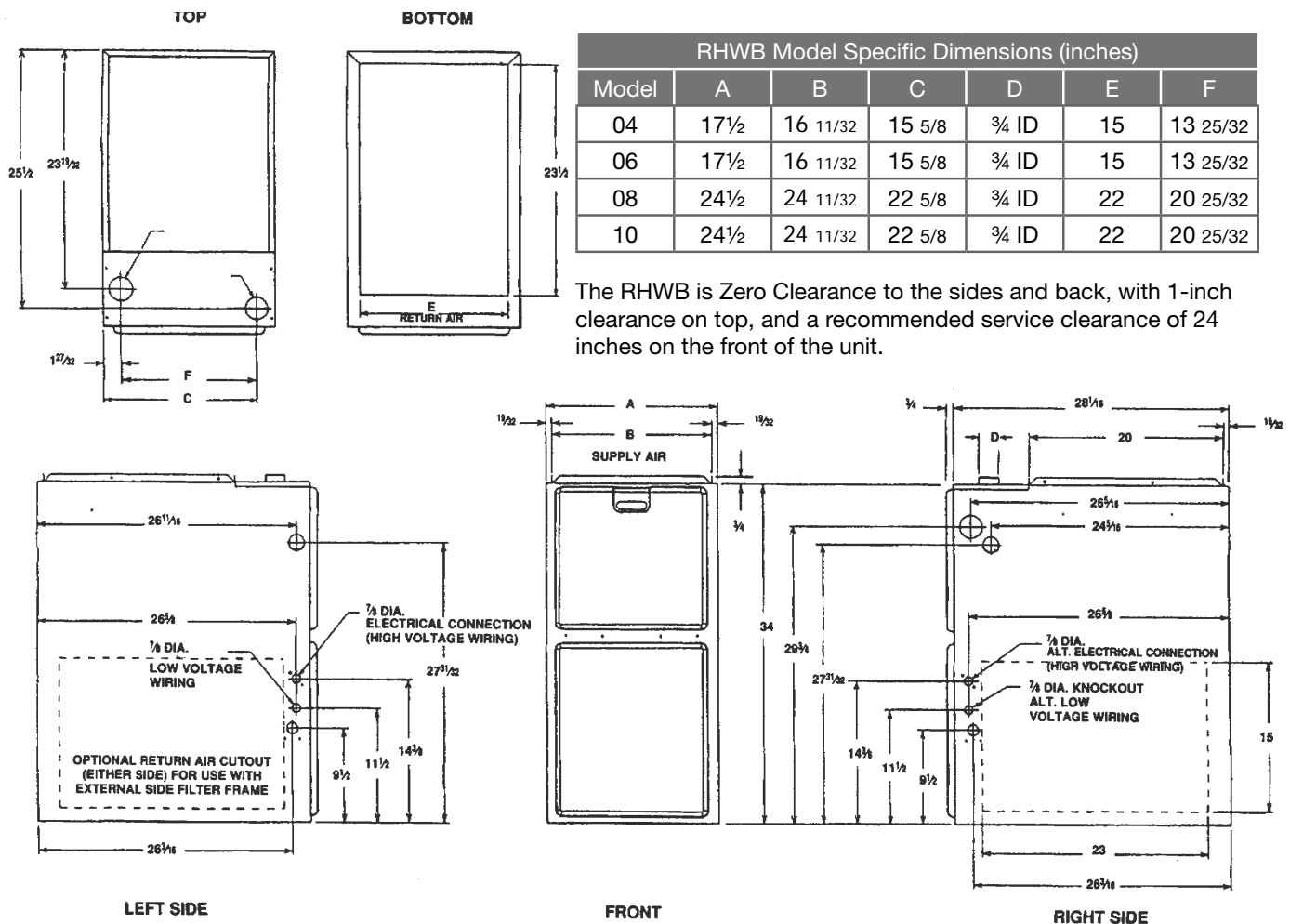

# INSTALLATION ACCESSORIES

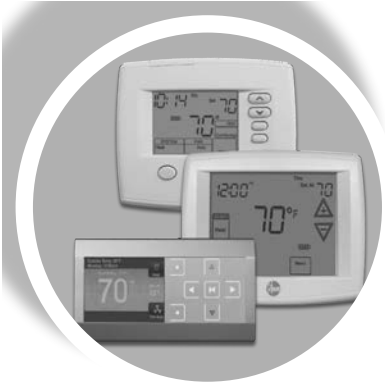

## Room Thermostats

The Rheem Thermostat line includes temperature control solutions for all Rheem residential and commercial HVAC equipment



## Ultraviolet Treatment Systems

Breathe cleaner air with a Rheem Ultraviolet Treatment System. If you want improved air quality in your home, install a Rheem UV-C Treatment System to work along side your Rheem central heating and cooling system.



## Air Cleaners

Improving the air in your home is easy with the Rheem Whole-House Electric Air Cleaner or the Rheem Whole-House Media Air Cleaner.

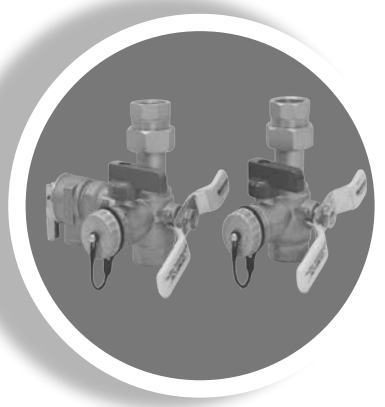

## Service Valves

The service valve kits available from Rheem offer an easy means to install and maintain your Rheem tankless water heater.



## Tankless Flush Kit

The Rheem tankless flush kit is an easy solution to flush mineral deposits your tankless water heater.



## Indoor Cooling Coils

Rheem Indoor Coils are designed for use with Rheem outdoor units. They can be matched with your Hydronic Air Handler.

# PROBLEMS OR QUESTIONS

If you need assistance with your Hydronic Air Handler please contact your local installing contractor, or Rheem distributor.

See the manufacturer's warranty for additional details.

Install Date: \_\_\_\_\_ Installed by : \_\_\_\_\_

Contact Number: \_\_\_\_\_ Contact Address: \_\_\_\_\_

*In keeping with its policy of continuous progress and product improvement, Rheem reserves the right to make changes without notice.*