

INSTALLATION INSTRUCTIONS

AIR HANDLERS

FEATURING INDUSTRY STANDARD R-410A REFRIGERANT: 

(-)H1V Premium Efficiency Single Stage with Aluminum Coil

(-)H2V Premium Efficiency Two Stage *Comfort Control² System™*
with Aluminum Coil



RECOGNIZE THIS SYMBOL AS AN INDICATION OF IMPORTANT SAFETY INFORMATION!

⚠ WARNING

These instructions are intended as an aid to qualified licensed service personnel for proper installation, adjustment and operation of this unit. Read these instructions thoroughly before attempting installation or operation. Failure to follow these instructions may result in improper installation, adjustment, service or maintenance possibly resulting in fire, electrical shock, property damage, personal injury or death.



ISO 9001:2008
Certificate Number: 30164

DO NOT DESTROY THIS MANUAL

PLEASE READ CAREFULLY AND KEEP IN A SAFE PLACE FOR FUTURE REFERENCE BY A SERVICEMAN



CONTENTS

1.0	SAFETY INFORMATION	3
2.0	GENERAL INFORMATION	5
2.1	Important Information About Efficiency and Indoor Air Quality	5
2.2	Model Number Explanation	6
2.3	Dimensions and Weights	7
2.4	Receiving	8
2.5	Clearances	9
3.0	APPLICATIONS	9
3.1	Zoning Systems	9
3.2	Vertical Upflow & Horizontal Left	10
3.3	Vertical Downflow & Horizontal Right	10
3.4	Installation in an Unconditioned Space	12
3.5	Installation in Mobile/Manufactured Homes	12
4.0	ELECTRICAL WIRING	13
4.1	Power Wiring	13
4.2	Copper Wire Size	13
4.3	Control Wiring	14
4.4	Typical Thermostat Wiring Diagrams (-)H1V, (-)H2V	15
4.5	Grounding	18
4.6	Blower Motor Electrical Data (-)H1V	18
4.7	Blower Motor Electrical Data (-)H2V	18
4.8	Conventional 24VAC Thermostat Control Wiring (-)H2V	19
4.9	Electric Heat Electrical Data (-)H1V	20
4.10	Electric Heat Electrical Data (-)H2V	22
4.11	Heater Kit Supplemental Information (-)H1V & (-)H2V	23
5.0	ECM MOTOR INTERFACE CONTROL BOARD	24
5.1	ECM Motor Interface Control & Settings	24
5.2	Using the On-board LED to Determine Blower CFM	25
5.3	Cooling Airflow Settings	25
5.4	Cooling Airflow Adjustments	26
5.5	Electric Heat Airflow Settings	26
5.6	Cooling Delay Profiles	27
5.7	Cooling Mode Dehumidification - Passive	27
5.8	Cooling Mode Dehumidification - Active	28
5.9	On Demand Dehumidification Airflow Adjustment - Active	29
5.10	Airflow Performance (-)H1V	30
5.11	Airflow Performance Data (-)H1V	30
6.0	AIRFLOW PERFORMANCE	32
6.1	Airflow Performance Data	32
6.2	Copper Wire Size - Awg. (3% Voltage Drop)	33
6.3	Blower Motor Electrical Data (-)H2V	33
6.4	Electric Heat Electrical Data	33
6.5	Cooling Airflow Settings	34
6.6	Cooling Airflow Adjustment (-)H2V	34
6.7	Electric Heat Airflow (-)H2V	34
6.8	Cooling Mode Dehumidification (-)H2V	35
6.9	Cooling Delay Profiles (-)H2V	35
6.10	Using the On-Board LED to determine Blower CFM (-)H2V	36
6.11	Cooling Airflow Settings	36
6.12	Cooling Airflow Adjustments	36
6.13	Airflow Adjustment	37
6.14	Electric Heat Airflow	37
6.15	Cooling Mode Dehumidification	37
6.16	Cooling Delay Profiles (-)H2V	38
6.17	Airflow Performance Data (-)H2V	39
6.18	Air Handler Diagnostic Codes (-)H2V	39
7.0	DUCTWORK	41
8.0	REFRIGERANT CONNECTIONS	42
8.1	TEV Sensing Bulb	42
8.2	Condensate Drain Tubing	43
8.3	Duct Flanges	43
9.0	AIR FILTER (Not Factory Installed)	44
10.0	SEQUENCE OF OPERATION	44
10.1	Cooling (cooling only & heat pump)	44
10.2	Heating (electric heat only)	44
10.3	Heating (heat pump)	44
10.4	Defrost	44
10.5	Emergency Heat	45
10.6	Room Thermostat	45
11.0	CALCULATIONS	45
11.1	Calculating Temperature Rise	45
11.2	Calculating BTUH Heating Capacity	45
11.3	Calculating Airflow CFM	46
11.4	Calculating Correction Factor	46
12.0	PRE-START CHECKLIST	46
13.0	MAINTENANCE	46
13.1	Air Filter	47
13.2	Indoor Coil/Drain Pan/Drain Line	47
13.3	The <i>Comfort Control System™</i> Control Board	47
13.4	Blower Motor & Wheel	48
13.5	Lubrication	48
13.6	Blower Assembly Removal and Replacement	48
13.7	Motor Replacement	48
13.8	ECM Control Module Replacement	49
13.9	Blower Wheel Replacement	51
14.0	REPLACEMENT PARTS	51
15.0	ACCESSORIES - KITS - PARTS	51

1.0 SAFETY INFORMATION

WARNING

Duct leaks can create an unbalanced system and draw pollutants such as dirt, dust, fumes and odors into the home causing property damage. Fumes and odors from toxic, volatile or flammable chemicals, as well as automobile exhaust and carbon monoxide (CO), can be drawn into the living space through leaking ducts and unbalanced duct systems causing personal injury or death (see Figure 1).

- If air-moving equipment or ductwork is located in garages or off-garage storage areas - all joints, seams, and openings in the equipment and duct must be sealed to limit the migration of toxic fumes and odors including carbon monoxide from migrating into the living space.
- If air-moving equipment or ductwork is located in spaces containing fuel burning appliances such as water heaters or boilers - all joints, seams, and openings in the equipment and duct must also be sealed to prevent depressurization of the space and possible migration of combustion byproducts including carbon monoxide into the living space.

WARNING (SEE SECTION 3.2: VERTICAL UPFLOW & HORIZONTAL LEFT)

If unit is to be installed without an indoor coil, return air duct, or plenum, it must not be installed directly over combustible material. If installed without an indoor coil with a return duct or plenum, the air plenum or duct must have a solid sheet metal bottom with no return air openings, registers or flexible air ducts located directly under the unit. Exposing combustible material to the return opening of an upflow unit without an indoor coil can cause a fire resulting in property damage, personal injury or death.

WARNING (SEE SECTION 14.7: ECM CONTROL MODULE REPLACEMENT)

Always have 240 volt power turned off to the furnace before attempting any replacement of the motor or control module. Failure to do so may result in serious equipment damage, personal injury or death.

WARNING (SEE SECTION 4.0: ELECTRICAL WIRING)

Disconnect all power to unit before installing or servicing. More than one disconnect switch may be required to de-energize the equipment. Hazardous voltage can cause severe personal injury or death.

WARNING (SEE SECTION 4.3: GROUNDING)

The unit must be permanently grounded. Failure to do so can result in electrical shock causing personal injury or death.

WARNING (SEE SECTION 14.0: MAINTENANCE)

Units with circuit breaker(s) meet requirements as a service disconnect switch, however, if access is required to the line side (covered) of the circuit breaker, this side of the breaker(s) will be energized with the breaker(s) de-energized. Contact with the line side can cause electrical shock resulting in personal injury or death.

WARNING (SEE SECTION 14.5: BLOWER ASSEMBLY REMOVAL & REPLACEMENT)

If removal of the blower assembly is required, all disconnect switches supplying power to the airhandler must be de-energized and locked (if not in sight of unit) so the field power wires can be safely removed from the blower assembly. Failure to do so can cause electrical shock resulting in personal injury or death.

Continued on next page →

WARNING

PROPOSITION 65: This appliance contains fiberglass insulation. Respirable particles of fiberglass are known to the State of California to cause cancer.

All manufacturer products meet current Federal OSHA Guidelines for safety. California Proposition 65 warnings are required for certain products, which are not covered by the OSHA standards.

California's Proposition 65 requires warnings for products sold in California that contain or produce any of over 600 listed chemicals known to the State of California to cause cancer or birth defects such as fiberglass insulation, lead in brass, and combustion products from natural gas.

All "new equipment" shipped for sale in California will have labels stating that the product contains and/or produces Proposition 65 chemicals. Although we have not changed our processes, having the same label on all our products facilitates manufacturing and shipping. We cannot always know "when, or if" products will be sold in the California market.

You may receive inquiries from customers about chemicals found in, or produced by, some of our heating and air-conditioning equipment, or found in natural gas used with some of our products. Listed below are those chemicals and substances commonly associated with similar equipment in our industry and other manufacturers.

- Glass Wool (Fiberglass) Insulation
- Carbon Monoxide (CO).
- Formaldehyde
- Benzene

More details are available at the websites for OSHA (Occupational Safety and Health Administration), at www.osha.gov and the State of California's OEHHA (Office of Environmental Health Hazard Assessment), at www.oehha.org. Consumer education is important since the chemicals and substances on the list are found in our daily lives. Most consumers are aware that products present safety and health risks, when improperly used, handled and maintained.

WARNING

The first 36 inches of supply air plenum and ductwork must be constructed of sheet metal as required by NFPA 90B. The supply air plenum or duct must have a solid sheet metal bottom directly under the unit with no openings, registers or flexible air ducts located in it. If flexible supply air ducts are used they may be located only in the vertical walls of a rectangular plenum, a minimum of 6 inches from the solid bottom. Metal plenum or duct may be connected to the combustible floor base, if not, it must be connected to the unit supply duct flanges such that combustible floor or other combustible material is not exposed to the supply air opening from the downflow unit. Exposing combustible (non-metal) material to the supply openings of a downflow unit can cause a fire resulting in property damage, personal injury or death.

WARNING (SEE SECTION 8.0: DUCTWORK)

Do not, under any circumstances, connect return ductwork to any other heat producing device such as fireplace insert, stove, etc. Unauthorized use of such devices may result in fire, carbon monoxide poisoning, explosion, personal injury or property damage.

WARNING

Because of possible damage to equipment or personal injury, installation, service, and maintenance should be performed by trained, qualified service personnel. Consumer service is recommended only for filter cleaning/replacement. Never operate the unit with the access panels removed.

WARNING (SEE SECTION 3.3: VERTICAL DOWNFLOW & HORIZONTAL RIGHT)

The RXHB-17, RXHB-21, or RXHB-24 combustible floor base is required when certain units are applied downflow on combustible flooring. Failure to use the base can cause a fire resulting in property damage, personal injury or death. See clearances for units requiring a combustible floor base. See the accessory section in this manual for combustible floor base RXHB-.

CAUTION (SEE SECTION 14.7: ECM CONTROL MODULE REPLACEMENT)

Reversing the 5-pin connector on the ECM motor causes immediate failure of the control module.

Continued on next page →

CAUTION (SEE SECTION 3.2: VERTICAL UPFLOW & HORIZONTAL LEFT)

Horizontal units must be configured for right hand air supply. Horizontal drain pan must be located under indoor coil. Failure to use the drain pan can result in property damage.

CAUTION (SEE SECTION 14.2: INDOOR COIL - DRAIN PAN - DRAIN LINE)

In compliance with recognized codes, it is recommended that an auxiliary drain pan be installed under all evaporator coils or units containing evaporator coils that are located in any area of a structure where damage to the building or building contents may occur as a result of an overflow of the coil drain pan or a stoppage in the primary condensate drain piping. See accessory section in this manual for secondary horizontal drain pan RXBM-.

⚠ NOTICE

When used on cooling applications, excessive sweating may occur when unit is installed in an unconditioned space. This can result in property damage.

⚠ NOTICE

Improper installation, or installation not made in accordance with the Underwriters Laboratory (UL) certification or these instructions, can result in unsatisfactory operation and/or dangerous conditions and are not covered by the unit warranty.

⚠ NOTICE

In compliance with recognized codes, it is recommended that an auxiliary drain pan be installed under all evaporator coils or units containing evaporator coils that are located in any area of a structure where damage to the building or building contents may occur as a result of an overflow of the coil drain pan or a stoppage in the primary condensate drain piping. See accessories section of these instructions for auxiliary horizontal overflow pan information (model RXBM).

⚠ NOTICE

Use of this air-handler during construction is not recommended. If operation during construction is absolutely required, the following temporary installation requirements must be followed:
Installation must comply with all Installation Instructions in this manual including the following items:

- Properly sized power supply and circuit breaker/fuse
- Air-handler operating under thermostatic control;
- Return air duct sealed to the air-handler;
- Air filters must be in place;
- Correct air-flow setting for application
- Removing the coil and storing it in a clean safe place is highly recommended until construction is completed and the outdoor unit is installed.
- Clean air-handler, duct work, and components including coil upon completion of the construction process and verify proper air-handler operating conditions according as stated in this instruction manual.
- NOTE: Electric strip heater elements tend to emit a burning odor for a few days if dust has accumulated during construction. Heater elements are easily damaged. Take great care when cleaning them. Low pressure compressed air is recommended for cleaning elements.

2.0 GENERAL INFORMATION

2.1 IMPORTANT INFORMATION ABOUT EFFICIENCY AND INDOOR AIR QUALITY

Central cooling and heating equipment is only as efficient as the duct system that carries the cooled or heated air. To maintain efficiency, comfort and good indoor air quality, it is important to have the proper balance between the air being supplied to each room and the air returning to the cooling and heating equipment.

Proper balance and sealing of the duct system improves the efficiency of the heating and air conditioning system and improves the indoor air quality of the home by reducing the amount of airborne pollutants that enter homes from spaces where the ductwork and / or equipment is located. The manufacturer and the U.S. Environmental Protection Agency's Energy Star Program recommend that central duct systems be checked by a qualified contractor for proper balance and sealing.

FIGURE 1
MIGRATION OF DANGEROUS SUBSTANCES, FUMES, AND ODORS INTO LIVING SPACES

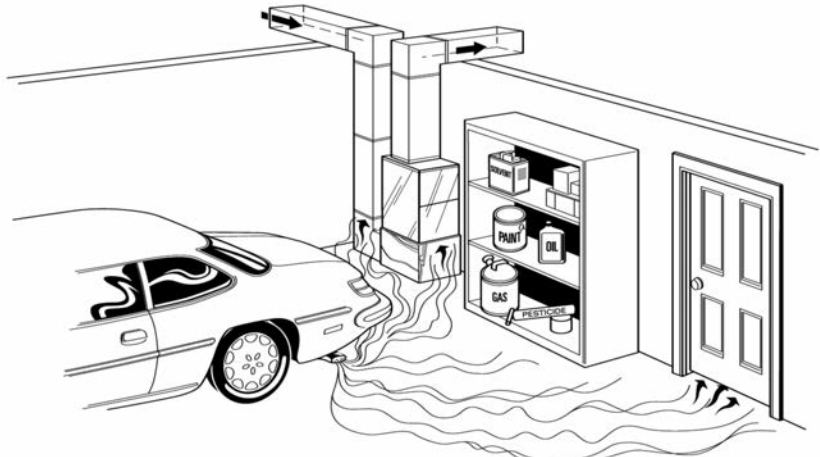

Adapted from *Residential Duct Diagnostics and Repair*, with permission of Air Conditioning Contractors of America (ACCA).

2.2 MODEL NUMBER EXPLANATION (SEE FIGURE 2)

FIGURE 2
MODEL NUMBER EXPLANATION

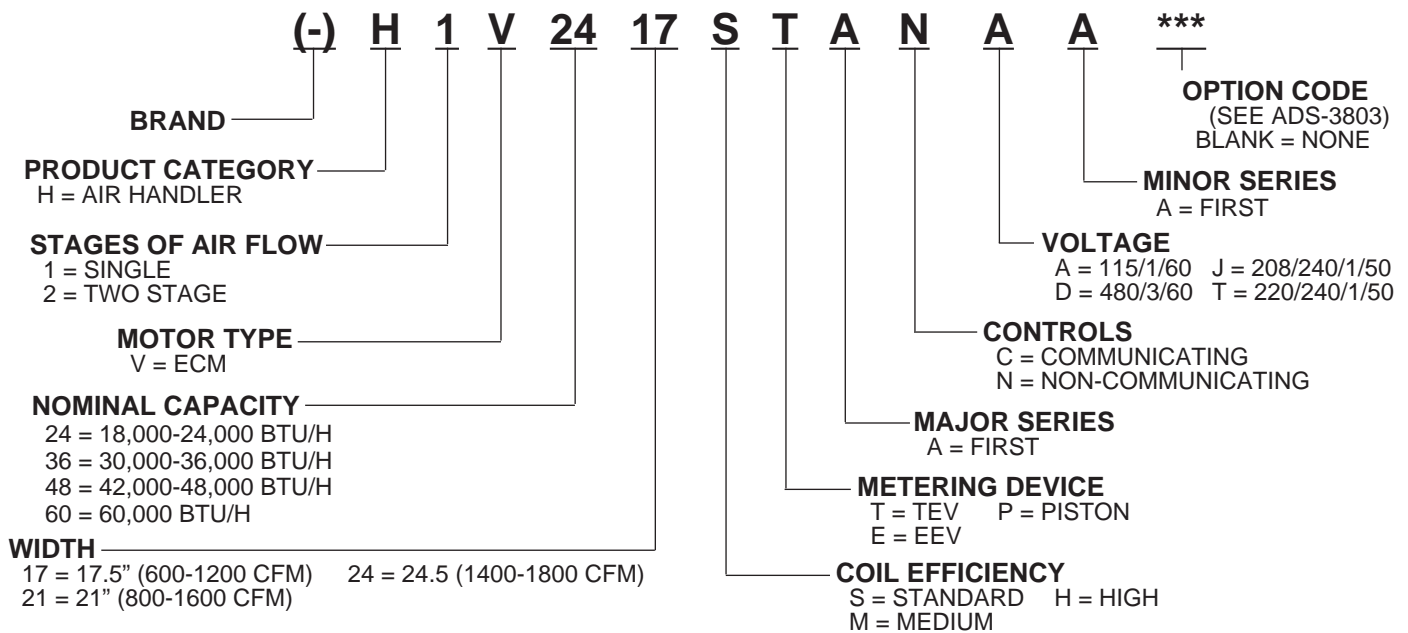

NOTES:

- 1) J Voltage (230V) single phase air handler is designed to be used with single or three phase 230 volt power. In the case of connecting 3-phase power to the air handler terminal block, bring only two leads to the terminal block. Cap, insulate and fully secure the third lead.
- 2) The air handlers are shipped from the factory with the proper indoor coil installed, and cannot be ordered without a coil.
- 3) Electric heat elements are field-installed items.
- 4) The air handlers do not have an internal filter rack. An external filter rack or other means of filtration is required.

AVAILABLE MODELS
RH1V2417STANJA
RH1V3617STANJA
RH1V3621MTANJA
RH1V4821STANJA
RH1V4824STANJA
RH1V6024STANJA

AVAILABLE MODELS
RH2V2421HTACJA
RH2V3624HTACJA
RH2V4824HTACJA
RH2V6024HTACJA

2.3 DIMENSIONS & WEIGHTS (SEE FIGURE 3)

FIGURE 3
DIMENSIONS AND WEIGHTS -- SINGLE COIL UNITS

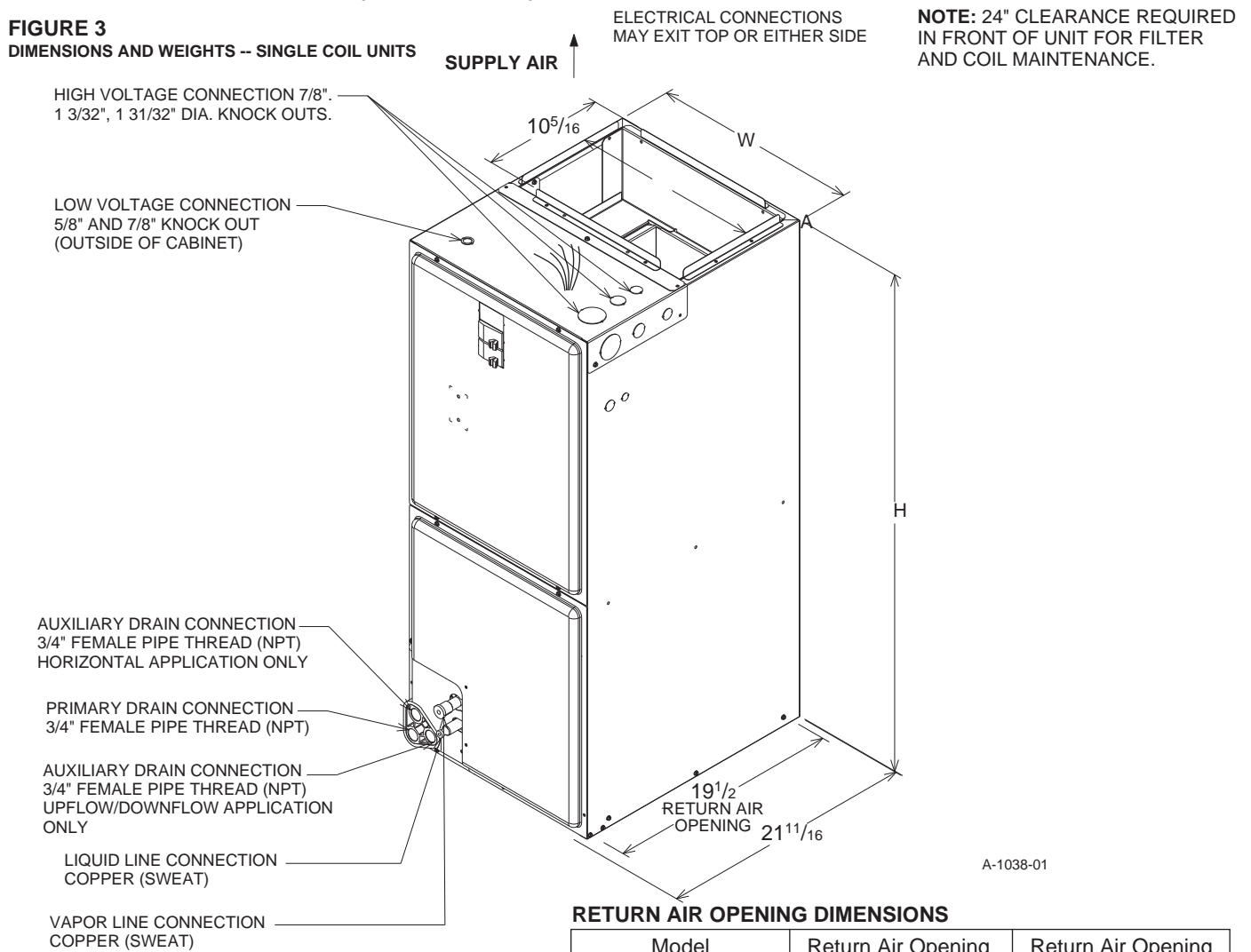

A-1038-01

UPFLOW UNIT SHOWN;
UNIT MAY BE INSTALLED UPFLOW, DOWNFLOW,
HORIZONTAL RIGHT, OR LEFT AIR SUPPLY.

RETURN AIR OPENING DIMENSIONS

Model Cabinet Size	Return Air Opening Width (Inches)	Return Air Opening Depth/Length (Inches)
17	15 ⁷ / ₈	19 ³ / ₄
21	19 ³ / ₈	19 ³ / ₄
24	22 ⁷ / ₈	19 ³ / ₄

DIMENSIONAL DATA

MODEL SIZE (-)H1V	REFRIGERANT CONNECTIONS		UNIT WIDTH "W" IN [mm]	UNIT HEIGHT "H" IN [mm]	SUPPLY DUCT "A" IN. [mm]	AIR FLOW COIL (NOM) [L/s]		UNIT WEIGHT / SHIPPING WEIGHT (LBS.) [kg]
	SWEAT (IN.) [mm] ID					LO	HI	
	LIQUID	VAPOR						UNIT WITH COIL (MAX. kW.)
2417ST	3/8" [9.53]	3/4" [19.05]	17 1/2" [445]	42 1/2" [1080]	16" [409]	600 [283]	800 [378]	82/96 [37/44]
3617ST	3/8" [9.53]	3/4" [19.05]	17 1/2" [445]	42 1/2" [1080]	16" [409]	1000 [472]	1200 [566]	90/104 [41/47]
3621MT	3/8" [9.53]	7/8" [22.23]	21" [533]	50 1/2" [1282]	19 1/2" [495]	1000 [472]	1200 [566]	126/142 [57/64]
4821ST	3/8" [9.53]	7/8" [22.23]	21" [533]	50 1/2" [1282]	19 1/2" [495]	1400 [661]	1600 [755]	130/146 [59/66]
4824ST	3/8" [9.53]	7/8" [22.23]	24 1/2" [622]	50 1/2" [1282]	23" [585]	1600 [755]	—	142/160 [64/72]
6024ST	3/8" [9.53]	7/8" [22.23]	24 1/2" [622]	55 1/2" [1410]	23" [585]	—	1800 [850]	162/179 [73/81]

MODEL SIZE (-)H2V	UNIT WIDTH "W" IN. [mm]	UNIT HEIGHT "H" IN. [mm]	SUPPLY DUCT "A" IN. [mm]	MATCHED TO OUTDOOR UNIT ¹	NOMINAL COIL AIRFLOW [L/s]				UNIT WEIGHT / SHIPPING WEIGHT (LBS.) [kg]
					1 ST STAGE		2 ND STAGE		
					ODD*	Normal	ODD*	Normal	UNIT WITH COIL (MAX. kW.)
2421HT	21 [533]	42 1/2 [1080]	19 1/2 [495]	(-)ARL/(-)ASL-024JEC	500 [236]	600 [283]	650 [307]	775 [366]	99/117 [45/51]
				(-)ASL-039JEC	725 [342]	825 [389]	975 [460]	1175 [555]	
				(-)ARL/(-)ASL-0935JEC	825 [389]	950 [448]	1000 [472]	1175 [555]	
4824HT	24 1/2 [622]	55 1/2 [1410]	23 [584]	(-)ASL-048JEC	825 [389]	1000 [472]	1300 [614]	1600 [755]	143/160 [65/72]
				(-)ARL-048JEC	1000 [472]	1200 [566]	1350 [637]	1600 [755]	
6024HT	24 1/2 [622]	55 1/2 [1410]	23 [584]	(-)ASL-060JEC	925 [437]	1050 [496]	1325 [625]	1700 [802]	159/176 [72/80]
				(-)ARL-060JEC	1025 [484]	1275 [602]	1400 [661]	1700 [802]	

⚠️ WARNING



Carbon Monoxide (CO) Poisoning Can Cause Severe Injury or Death.

Carbon Monoxide from the exhaust of motor vehicles and other fuel burning devices can be drawn into the living space by the operation of the central heating and air conditioning system.

Exhaust from motor vehicles, generators, garden tractors, mowers, portable heaters, charcoal and gas grills, gasoline powered tools, and outdoor camping equipment contains carbon monoxide, a poisonous gas that can kill you. You cannot see it, smell it, or taste it.

- Do NOT operate an automobile or any engine in a garage for more than the few seconds it takes to enter or exist the garage.
- Do NOT operate any fuel-burning device in an enclosed or partly enclosed space, or near building windows, doors or air intakes.

The U.S. Consumer Product Safety Commission (CPSC) and Health Canada recommend the installation of UL or CSA certified Carbon Monoxide Alarm(s) in every home.

⚠️ WARNING

Duct leaks can create an unbalanced system and draw pollutants such as dirt, dust, fumes and odors into the home causing property damage. Fumes and odors from toxic, volatile or flammable chemicals, as well as automobile exhaust and carbon monoxide (CO), can be drawn into the living space through leaking ducts and unbalanced duct systems causing personal injury or death (see Figure 1).

- If air-moving equipment or ductwork is located in garages or off-garage storage areas - all joints, seams, and openings in the equipment and duct must be sealed to limit the migration of toxic fumes and odors including carbon monoxide from migrating into the living space.
- If air-moving equipment or ductwork is located in spaces containing fuel burning appliances such as water heaters or boilers - all joints, seams, and openings in the equipment and duct must also be sealed to prevent depressurization of the space and possible migration of combustion byproducts including carbon monoxide into the living space.

⚠️ NOTICE

Improper installation, or installation not made in accordance with the Underwriters Laboratory (UL) certification or these instructions, can result in unsatisfactory operation and/or dangerous conditions and are not covered by the unit warranty.

⚠️ NOTICE

In compliance with recognized codes, it is recommended that an auxiliary drain pan be installed under all evaporator coils or units containing evaporator coils that are located in any area of a structure where damage to the building or building contents may occur as a result of an overflow of the coil drain pan or a stoppage in the primary condensate drain piping. See accessories section of these instructions for auxiliary horizontal overflow pan information (model RXBM).

2.4 RECEIVING

Immediately upon receipt, all cartons and contents should be inspected for transit damage. Units with damaged cartons should be opened immediately. If damage is found, it should be noted on the delivery papers, and a damage claim filed with the last carrier.

- After unit has been delivered to job site, remove carton taking care not to damage unit.
- Check the unit rating plate for unit size, electric heat, coil, voltage, phase, etc. to be sure equipment matches what is required for the job specification.
- Read the entire instructions before starting the installation.
- Some building codes require extra cabinet insulation and gasketing when unit is installed in attic applications.
- If installed in an unconditioned space, apply caulking around the power wires, control wires, refrigerant tubing and condensate line where they enter the cabinet. Seal the power wires on the inside where they exit conduit opening. Caulking is required to pre-vent air leakage into and condensate from forming inside the unit, control box, and on electrical controls.
- Install the unit in such a way as to allow necessary access to the coil/filter rack and blower/control compartment.
- Install the unit in a level position to ensure proper condensate drainage. Make sure unit is level in both directions within 1/8".
- Install the unit in accordance with any local code which may apply and the national codes. Latest editions are available from: "National Fire Protection Association, Inc., Batterymarch Park, Quincy, MA 02269." These publications are:
 - ANSI/NFPA No. 70-(Latest Edition) National Electrical Code.
 - NFPA90A Installation of Air Conditioning and Ventilating Systems.
 - NFPA90B Installation of warm air heating and air conditioning systems.
- The equipment has been evaluated in accordance with the Code of Federal Regulations, Chapter XX, Part 3280.

2.5 CLEARANCES

- All units are designed for “0” inches clearance to combustible material on all cabinet surfaces.
- Units with electric heat require a one inch clearance to combustible material for the first three feet of supply plenum and ductwork.
- Some units require a combustible floor base depending on the heating kW. The following table should be used to determine these requirements.

Model Cabinet Size	17	21	24
Model Designation kW	15	18	20

Additionally, if these units are installed down-flow, a combustible floor base is required. See Accessories for Combustible Floor Base RXHB-XX.

Units with electric heating kW equal to or less than the values listed in the table do not require a combustible floor base.

- Vertical units require clearance on at least one side of the unit for electrical connections. Horizontal units require clearance on either top or bottom for electrical connections. Refrigerant and condensate drain connections are made on the front of the unit. (See Figure 4.)
- All units require 24 inches maximum access to the front of the unit for service.
- These units may be installed in either ventilated or nonventilated spaces.

FIGURE 4
DIMENSIONS FOR FRONT CONNECT COIL

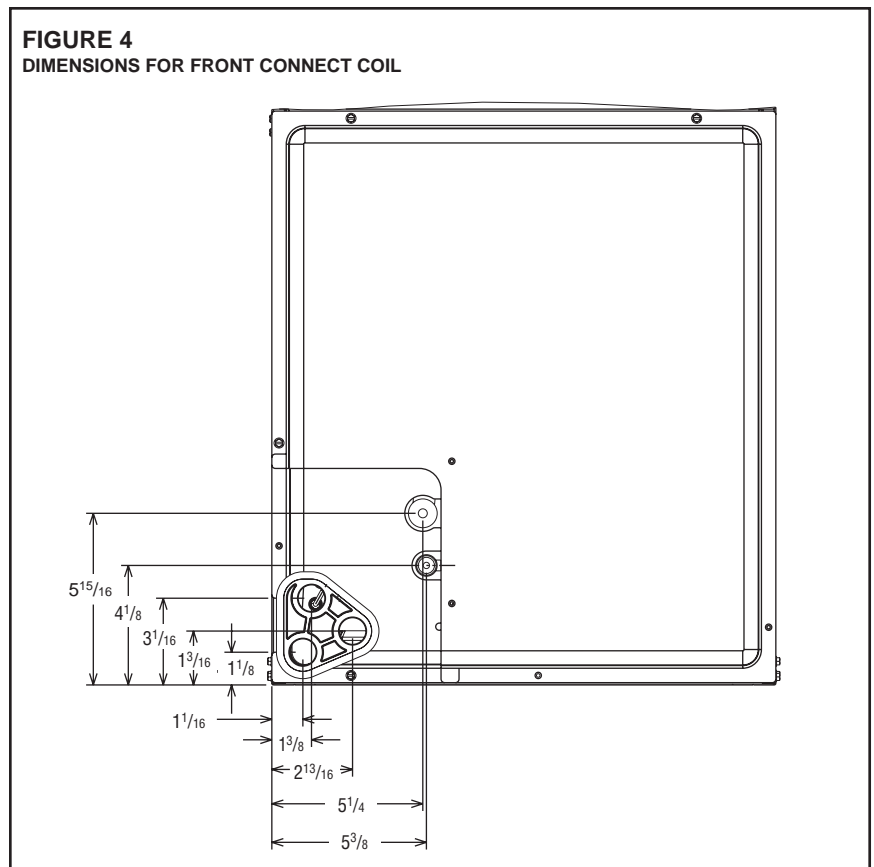

3.0 APPLICATIONS

3.1 ZONING SYSTEMS

The manufacturer does not currently provide or support zoning. However, zoning systems can be installed with a variable speed air-handler as long as the zoning equipment manufacturers specifications and installation instructions are met and followed.

The preferred zoning method is to use a “bypass” system which is properly installed for maximum efficiency. In these systems, excess air is routed back through the system to be used again – this is opposed to a “dump” system in which excess air is routed to a zone where it is expected that the extra heat or cooling would be least noticed.

If installed as a “bypass” system, the installation must have an optional freeze stat installed to prevent the coil from icing with excess bypass cooling. Also, if the zoning equipment manufacturer provides a limit switch (usually provided by the zoning manufacturer), this limit must be installed in the system to prevent the furnace from overheating.

3.2 VERTICAL UPFLOW AND HORIZONTAL LEFT

The air handler unit is factory shipped for vertical upflow and horizontal left application.

- If return air is to be ducted, install duct flush with floor. Use fireproof resilient gasket 1/8 to 1/4 in. thick between duct, unit and floor. Set unit on floor over opening.
- Support along the length of the unit, on all units installed horizontally. Do not support or suspend unit from both ends without support in the center of the cabinet. If unit is to be supported or suspended from corners, run two reinforcing rails length of unit and support or suspend from reinforcing rails.
- Secondary drain pan kits RXBM- are required when the unit is configured for the horizontal left position over a finished ceiling and/or living space. (See Section 16.0: Accessories - Kits - Parts.)

FIGURE 5
VERTICAL DOWNFLOW & HORIZONTAL RIGHT APPLICATIONS

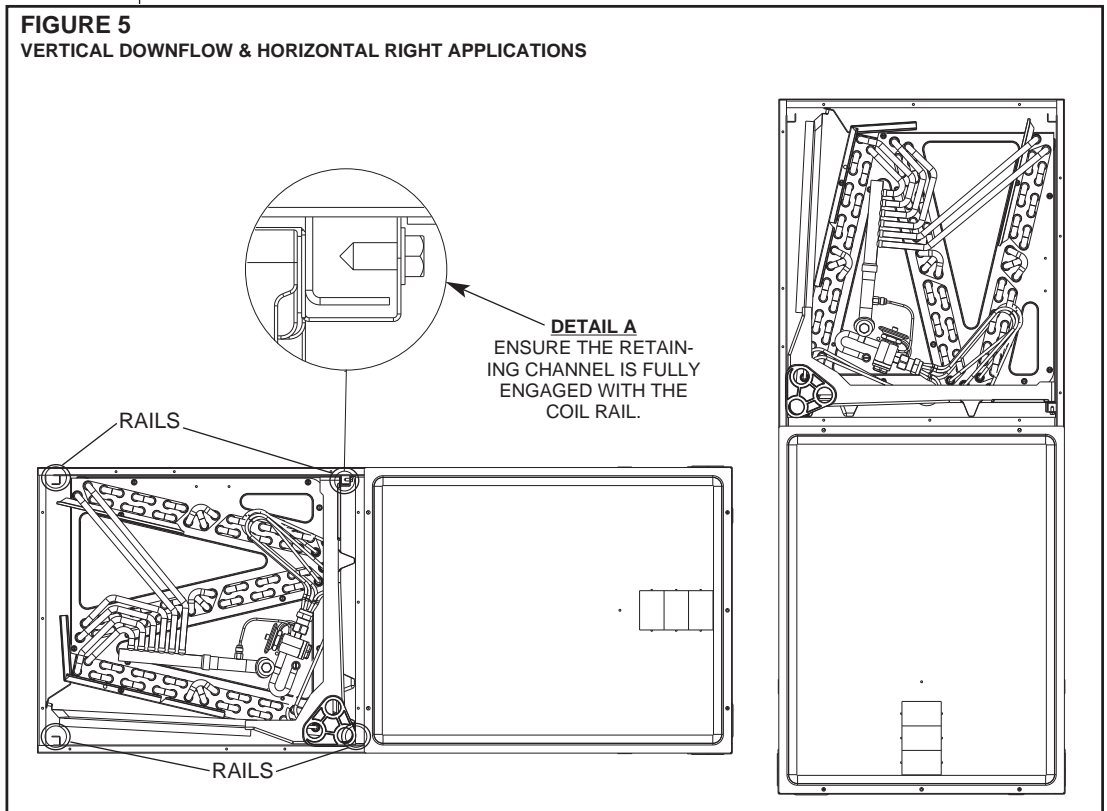

CAUTION

Horizontal units must be configured for right hand air supply. Horizontal drain pan must be located under indoor coil. Failure to use the drain pan can result in property damage.

3.3 VERTICAL DOWNFLOW AND HORIZONTAL RIGHT

Conversion to Vertical Downflow/Horizontal Right: A vertical upflow unit may be converted to vertical downflow/horizontal right. (See Figure 5.) Remove the door and indoor coil.

IMPORTANT: To comply with certification agencies and the National Electric Code for horizontal right application, the circuit breaker(s) on field-installed electric heater kits must be re-installed per procedure below so that the breaker switch "on" position and marking is up and, "off" position and marking is down.

- To turn breaker(s): Rotate one breaker pair (circuit) at a time starting with the one on the right. Loosen both lugs on the load side of the breaker. Wires are bundles with wire ties, one bundle going to the right lug and one bundle going to the left lug.
- Using a screwdriver or pencil, lift white plastic tab with hole away from breaker until breaker releases from mounting opening (see Figure 6).
- With breaker held in hand, rotate breaker so that "on" position is up, "off" position is down with unit in planned vertical mounting position. Insert right wire bundle into top right breaker lug, ensuring all strands of all wires are inserted fully into lug, and no wire insulation is in lug.

FIGURE 6
ROTATING CIRCUIT BREAKER

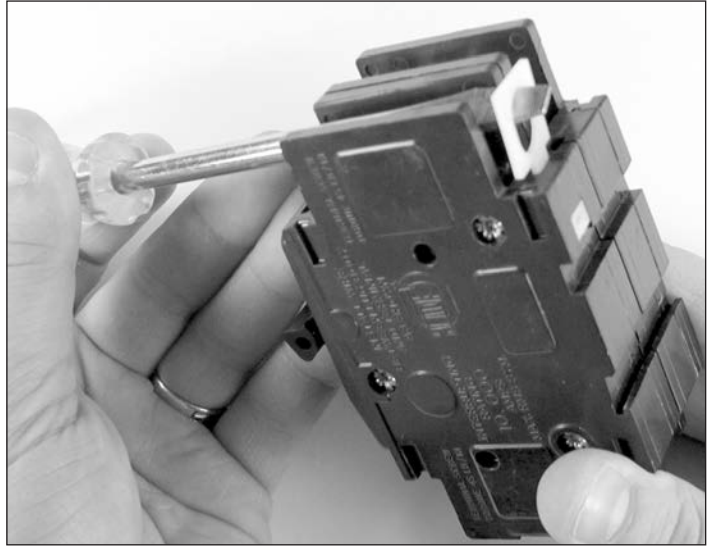

- Tighten lug as tight as possible while holding circuit breaker. Check wires and make sure each wire is secure and none are loose. Repeat for left wire bundle in left top circuit breaker lug.
- Replace breaker by inserting breaker mounting tab opposite white pull tab in opening, hook mounting tab over edge in opening.
- With screwdriver or pencil, pull white tab with hole away from breaker while setting that side of breaker into opening. When breaker is in place, release tab, locking circuit breaker into location in opening.
- Repeat above operation for remaining breaker(s) (if more than one is provided).
- Replace single point wiring jumper bar, if it is used, on line side of breaker and tighten securely.
- Double check wires and lugs to make sure all are secure and tight. Check to make sure unit wiring to circuit breaker load lugs match that shown on the unit wiring diagram.

DRIP LOOP: When installing the unit in down-flow or horizontal-right positions, make sure that the wires coming from the motor form a proper drip loop. This allows water to cascade off the lowest point of the wiring before it enters the motor head. This may require cutting the wire tie and installing a new wire tie to form this loop.

WARNING

The RXHB-17, RXHB-21, or RXHB-24 combustible floor base is required when certain units are applied downflow on combustible flooring. Failure to use the base can cause a fire resulting in property damage, personal injury or death. See clearances for units requiring a combustible floor base. See the accessory section in this manual for combustible floor base RXHB-.

- Rotate unit into the downflow position, with the coil compartment on top and the blower compartment on bottom.
- The set of coil rails must be moved for vertical down-flow and horizontal right application. Remove the coil rail from the factory configuration (6 screws in all). Fastener clearance holes will need to be drilled in the cabinet sides (proper hole locations are marked with “dimples” for this purpose). Note that the shorter (no notch) coil rail must be mounted on the left-hand side to provide clearance for the drain pan condensate connection boss.
- Reinstall the indoor coil 180° from original position. Ensure the retaining channel is fully engaged with the coil rail. (See Figure 5, Detail A.)
- Secondary drain pan kits RXBM- are required when the unit is configured for the horizontal right position over a finished ceiling and/or living space. (See Section 16.0: Accessories - Kits - Parts.)

IMPORTANT: Units cannot be installed horizontally laying on or suspended from the back of the unit.

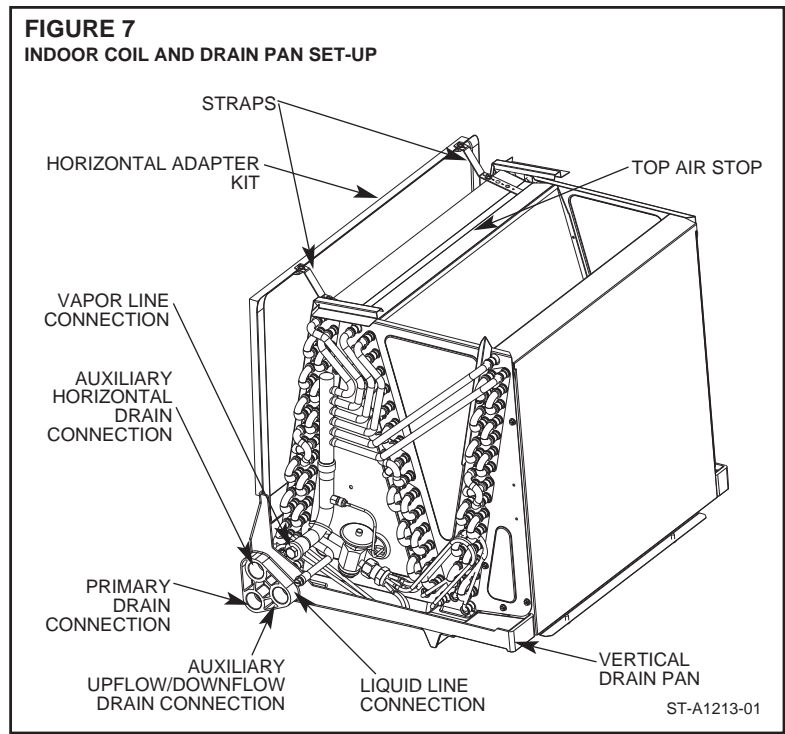

3.4 INSTALLATION IN AN UNCONDITIONED SPACE

The exterior cabinet of an air handler has a greater risk of sweating when installed in an unconditioned space than when it is installed in the conditioned space. This is primarily due to the temperature of the conditioned air moving through the air handler and the air circulating around the unit where it is installed. For this reason, we recommend the following for all air handler applications, but special attention should be paid to those installed in unconditioned spaces:

- Duct sizing and airflow are critical and based on the equipment selected
- Supply and return duct attachment: If other than the factory flanges are used, the attachment of ducting must be insulated and tight to prevent sweating.
- No perimeter supply flanges are provided. If a full perimeter supply duct is used, it is the responsibility of the installer to provide duct flanges as needed, to secure and seal the supply duct to prevent air leakage and the sweating that will result.
- All wire penetrations should be sealed. Take care not to damage, remove or compress insulation in those cases.
- In some cases, the entire air handler can be wrapped with insulation. This can be done as long as the unit is completely enclosed in insulation, sealed and service access is provided to prevent accumulation of moisture inside the insulation.
- As required, use a secondary pan that will protect the structure from excessive sweating or a restricted coil drain line.
- If a heater kit is installed, be sure the breaker or disconnect cover is sealed tightly to the door panel.

3.5 INSTALLATION IN MOBILE/MANUFACTURED HOMES

1. Air handler must be secured to the structure using “L” brackets or pipe strap.
2. Allow a minimum of 24 inches (610 mm) front clearance required to access doors.
3. Recommended method for securing air handler:
 - A. If air handler is against the wall, secure top of air handler to wall stud using two 16ga thick angle brackets one on each side. Attach brackets with No. 10 self-tapping $\frac{1}{2}$ ” long screws to air handler and use $\frac{5}{16}$ ” lag screws $1\frac{1}{2}$ ” long to wall stud. Secure bottom of unit with two 16ga “L” brackets with No. 10 self-tapping $\frac{1}{2}$ ” long screws to air handler and use $\frac{5}{16}$ ” lag screws $1\frac{1}{2}$ ” long to floor.

- B. If air handler is away from wall attach pipe strap to top of air handler using No. 10 $\frac{1}{2}$ " long self-tapping screws on both sides. Angle strap down and away from back of air handler, remove all slack, and fasten to wall stud of structure using $\frac{5}{16}$ " lag screws $1\frac{1}{2}$ " long. Secure bottom of unit with two 16ga "L" brackets with No. 10 self-tapping screws to air handler and use $\frac{5}{16}$ " lag screws $1\frac{1}{2}$ " long to floor.

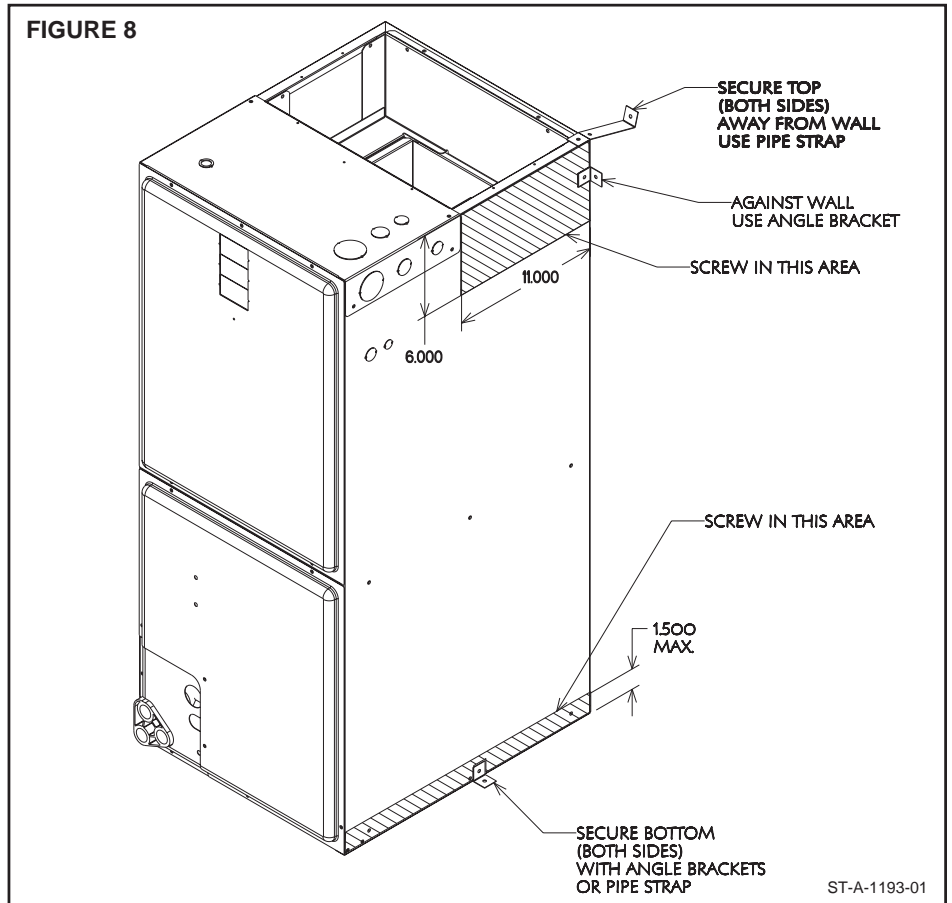

4.0 ELECTRICAL WIRING

Field wiring must comply with the National Electric Code (C.E.C. in Canada) and any applicable local ordinance.

⚠ WARNING

Disconnect all power to unit before installing or servicing. More than one disconnect switch may be required to de-energize the equipment. Hazardous voltage can cause severe personal injury or death.

4.1 POWER WIRING

It is important that proper electrical power is available for connection to the unit model being installed. See the unit nameplate, wiring diagram and electrical data in the installation instructions.

- If required, install a branch circuit disconnect of adequate size, located within sight of, and readily accessible to the unit.
- **IMPORTANT:** After the Electric Heater is installed, units may be equipped with one, two, or three 60 amp. circuit breakers. These breaker(s) protect the internal wiring in the event of a short circuit and serve as a disconnect. Circuit breakers installed within the unit do not provide over-current protection of the supply wiring and therefore may be sized larger than the branch circuit protection.
- Supply circuit power wiring must be 75°C minimum copper conductors only. See Electrical Data in this section for ampacity, wire size and circuit protector requirement. Supply circuit protective devices may be either fuses or "HACR" type circuit breakers.
- Power wiring may be connected to either the right, left side or top. Three $\frac{7}{8}$ ", $1\frac{3}{32}$ ", $1\frac{31}{32}$ " dia. concentric knockouts are provided for connection of power wiring to unit.
- Power wiring is connected to the power terminal block(s) in unit control compartment.

4.2 COPPER WIRE SIZE - AWG. (3% VOLTAGE DROP)

S U P P L Y W I R E	L E N G T H F E E T	200 [61]	12	10	8	8	8	6	6	6	4	4	3	3	2	2	1	0	00	
		150 [46]	12	10	10	10	8	8	6	6	6	4	4	3	3	2	2	1	0	00
		100 [30]	14	12	10	10	8	8	8	6	6	4	4	3	3	2	2	1	0	00
		50 [15]	14	12	10	10	8	8	8	6	6	4	4	3	3	2	2	1	0	00
SUPPLY CIRCUIT AMPACITY																				
NOTE: WIRE BASED ON COPPER CONDUCTORS 75°C MINIMUM RATING. FOR MORE THAN 3 CONDUCTORS IN A RACEWAY OR CABLE, SEE N.E.C. FOR DERATING THE AMPACITY OF EACH CONDUCTOR.																				

4.3 CONTROL WIRING

IMPORTANT: Class 2 low voltage control wire should not be run in conduit with power wiring and must be separated from power wiring, unless Class 1 wire of proper voltage rating is used.

- Low voltage control wiring should be 18 AWG color-coded (105°C minimum). For lengths longer than 100 ft., 16 AWG wire should be used.
- Low voltage control connections are made by extending wires from top of air handler using wire nuts.
- See wiring diagrams attached to indoor and outdoor sections to be connected
- Do not leave excess field control wiring inside unit, pull excess control wire to outside of unit and provide strain relief for field control wiring on inside of cabinet at point wiring penetrates cabinet.
- Make sure, after installation, separation of control wiring and power wiring has been maintained.

FIELD WIRE SIZE FOR 24 VOLT THERMOSTAT CIRCUITS

Thermostat Load - Amps	SOLID COPPER WIRE - AWG.					
	3.0	16	14	12	10	10
2.5	16	14	12	12	10	10
2.0	18	16	14	12	12	10
	50	100	150	200	250	300
	Length of Run - Feet (1)					

(1) Wire length equals twice the run distance.

NOTE: Do not use control wiring smaller than No. 18 AWG between thermostat and outdoor unit.

4.4 Typical Thermostat Wiring Diagrams (-)H1V

NOTE: These low voltage application diagrams are generic. Your indoor/ outdoor units may not have all the characteristics shown or may not wire exactly as shown. Refer to the diagrams and information sent with your indoor/outdoor sections.

WIRE COLOR CODE			
BK – BLACK	G – GREEN	PR – PURPLE	Y – YELLOW
BR – BROWN	GY – GRAY	R – RED	
BL – BLUE	O – ORANGE	W – WHITE	

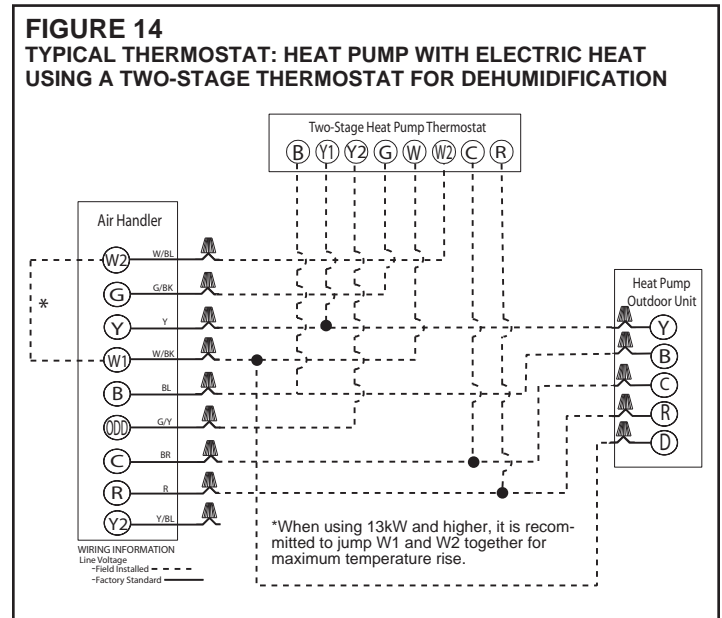
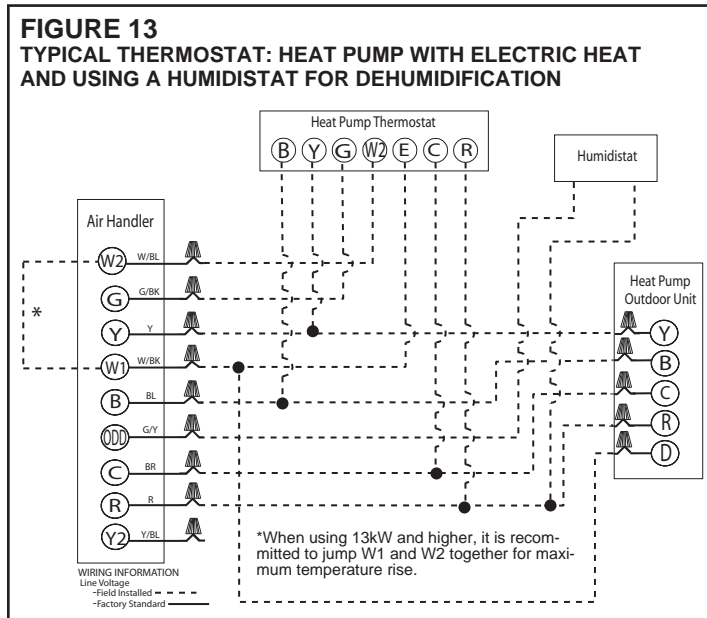
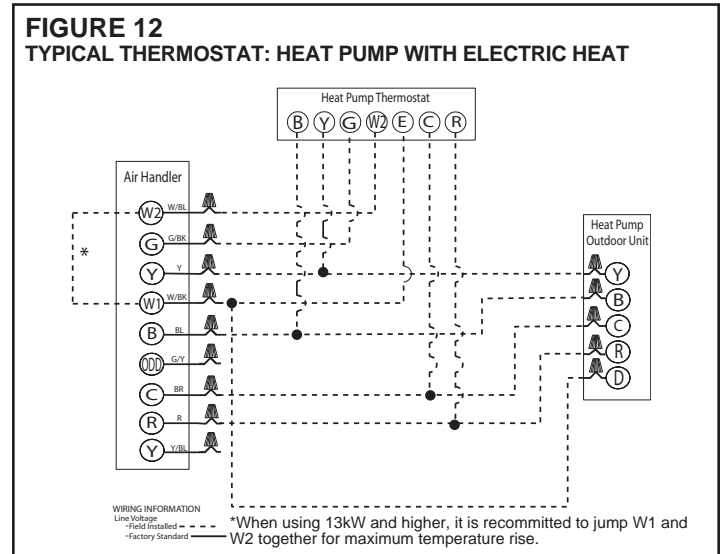
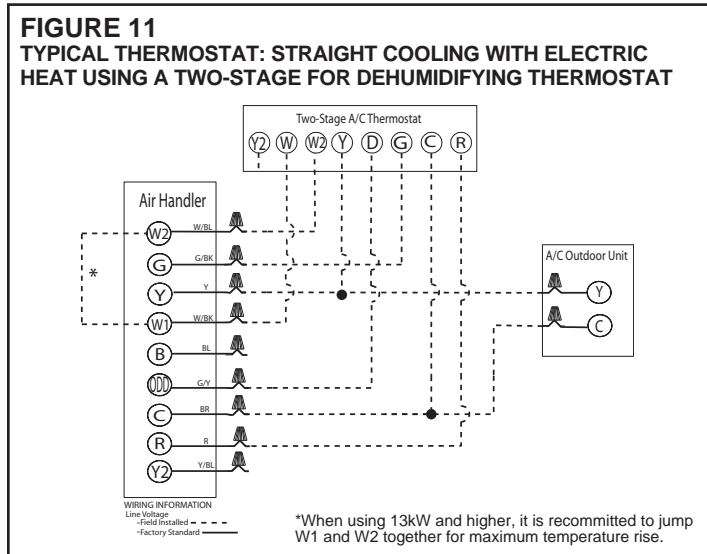
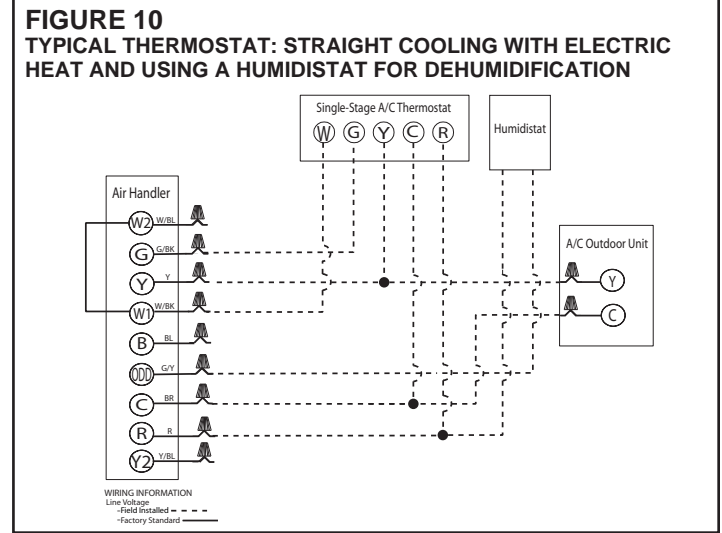
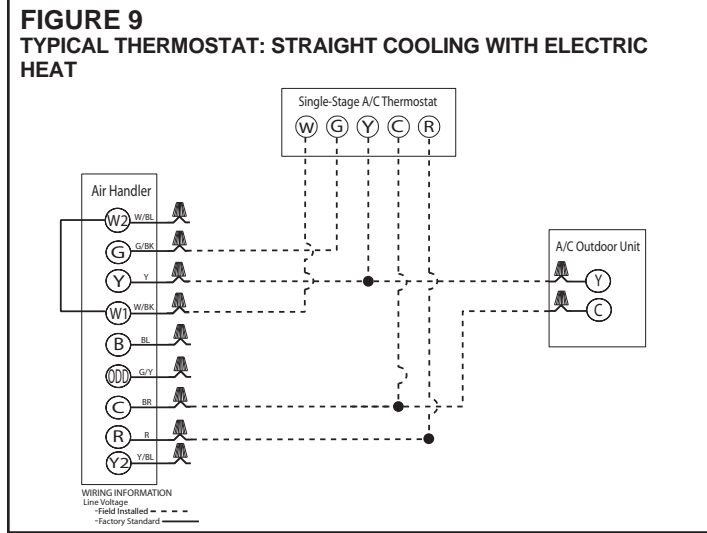

4.4 Typical Thermostat Wiring Diagrams (-)H2V

WIRE COLOR CODE			
BK - BLACK	G - GREEN	PR - PURPLE	Y - YELLOW
BR - BROWN	GY - GRAY	R - RED	
BL - BLUE	O - ORANGE	W - WHITE	

FIGURE 15
TYPICAL 2-STAGE THERMOSTAT: 2-STAGE CONDENSING UNIT WITH ELECTRIC HEAT

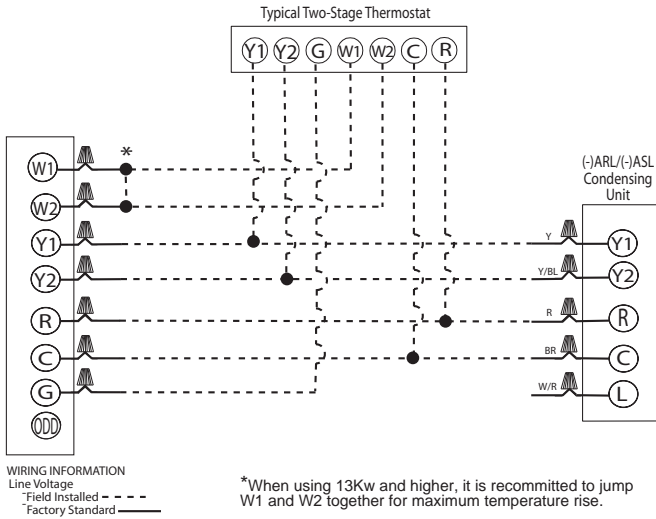

DIP SWITCH POSITIONS

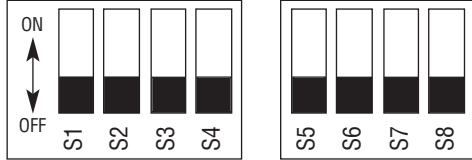
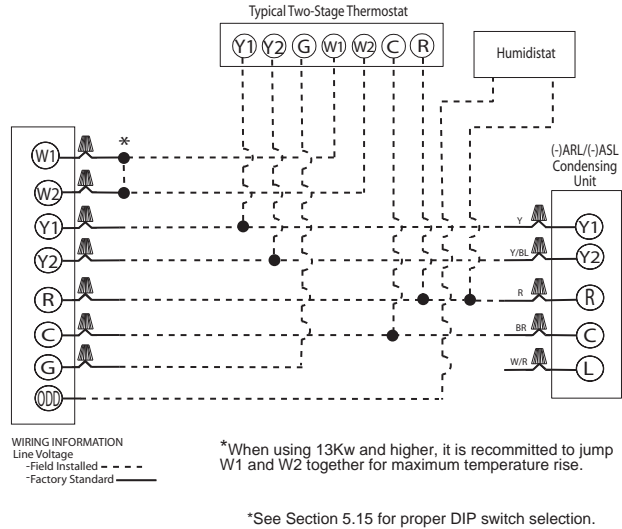

FIGURE 16
TYPICAL TWO-STAGE THERMOSTAT: 2-STAGE CONDENSING UNIT WITH ELECTRIC HEAT USING A HUMIDISTAT FOR DEHUMIDIFICATION*.



DIP SWITCH POSITIONS

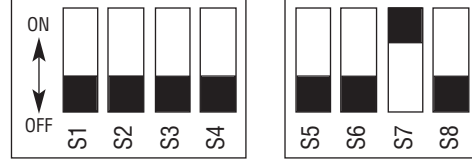
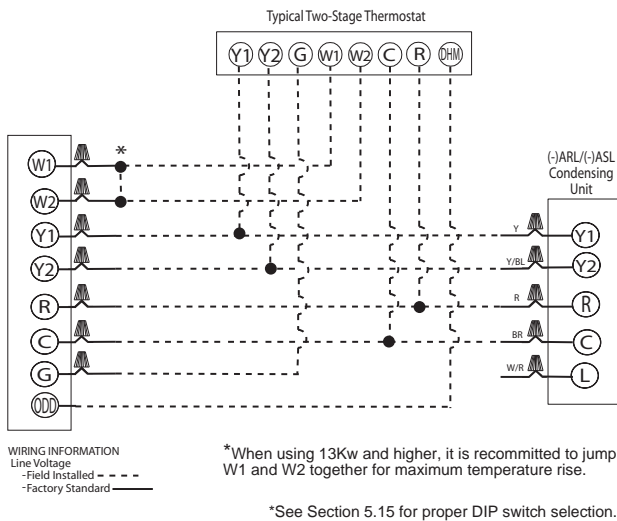

FIGURE 17
TYPICAL TWO-STAGE THERMOSTAT: 2-STAGE CONDENSING UNIT WITH ELECTRIC HEAT USING A TWO-STAGE THERMOSTAT WITH DEHUMIDIFICATION*



DIP SWITCH POSITIONS

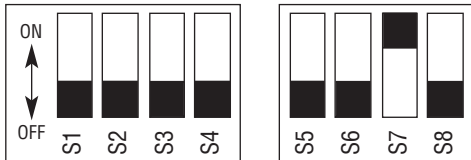
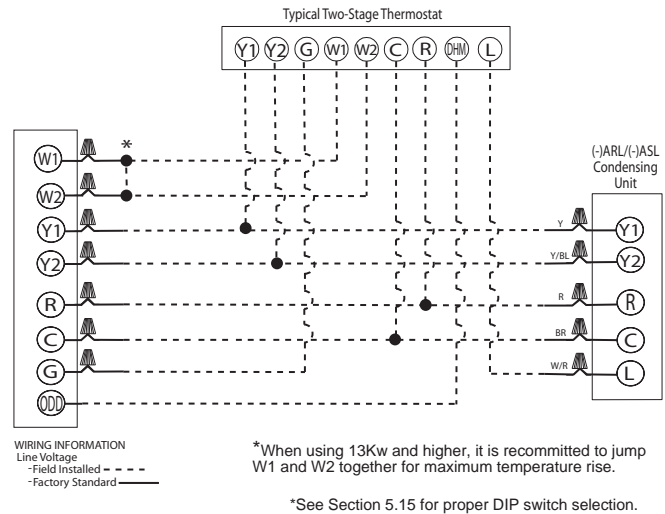

FIGURE 18
2-STAGE CONDENSING UNIT WITH ELECTRIC HEAT USING A TWO-STAGE THERMOSTAT WITH DEHUMIDIFICATION* AND A MALFUNCTION LIGHT



DIP SWITCH POSITIONS



4.4 Typical Thermostat Wiring Diagrams (-)H2V - continued

WIRE COLOR CODE			
BK – BLACK	G – GREEN	PR – PURPLE	Y – YELLOW
BR – BROWN	GY – GRAY	R – RED	
BL – BLUE	O – ORANGE	W – WHITE	

FIGURE 19
TYPICAL SINGLE-STAGE THERMOSTAT: SINGLE STAGE STRAIGHT COOLING WITH ELECTRIC HEAT
1st STAGE AIR FLOW

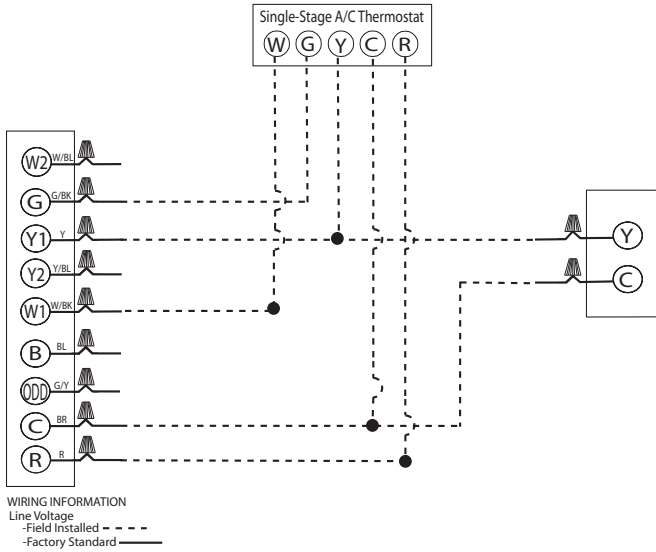

FIGURE 20
TYPICAL SINGLE-STAGE THERMOSTAT: SINGLE STAGE STRAIGHT COOLING WITH ELECTRIC HEAT AND USING A HUMIDISTAT FOR DEHUMIDIFICATION
1st STAGE AIR FLOW

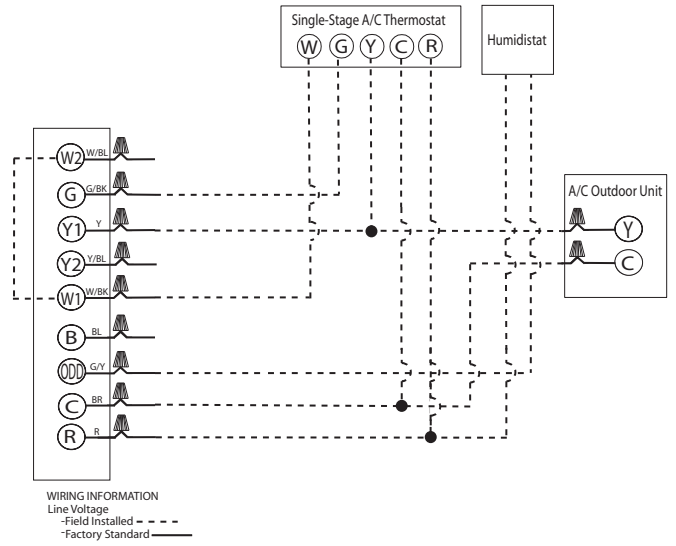

FIGURE 21
TYPICAL SINGLE-STAGE THERMOSTAT: SINGLE STAGE STRAIGHT COOLING WITH ELECTRIC HEAT
2ND STAGE AIR FLOW

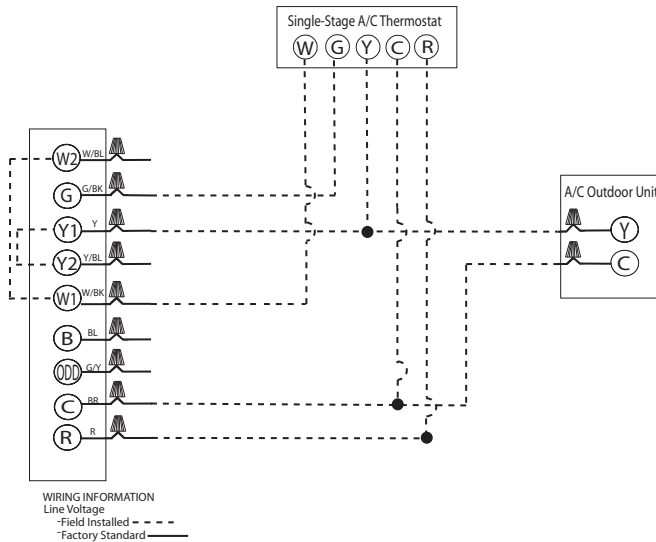
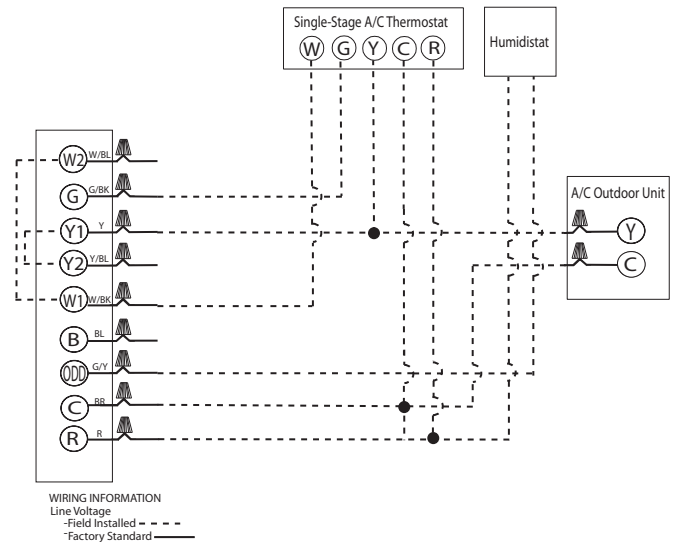

FIGURE 22
SINGLE STAGE STRAIGHT COOLING WITH ELECTRIC HEAT AND USING A HUMIDISTAT FOR DEHUMIDIFICATION
2ND STAGE AIR FLOW



4.5 GROUNDING

WARNING

The unit must be permanently grounded. Failure to do so can result in electrical shock causing personal injury or death.

- Grounding may be accomplished by grounding metal conduit when installed in accordance with electrical codes to the unit cabinet.
- Grounding may also be accomplished by attaching ground wire(s) to ground lug(s) provided in the unit wiring compartment.
- Ground lug(s) are located close to wire entrance on left side of unit (upflow). Lug(s) may be moved to marked locations near wire entrance on right side of unit (upflow), if alternate location is more convenient.
- Use of multiple supply circuits require grounding of each circuit to lug(s) provided in unit.

4.6 BLOWER MOTOR ELECTRICAL DATA (-)H1V

MODEL SIZE (-)H1V	VOLTAGE	PHASE	HERTZ	HP	RPM	SPEEDS	CIRCUIT AMPS	MINIMUM CIRCUIT AMPACITY	MAXIMUM CIRCUIT PROTECTOR
2417ST	208/240	1	60	1/3	300-1100	2	2.2	3	15
3617ST	208/240	1	60	1/2	300-1100	2	3.1	4.0	15
3621MT/4821ST	208/240	1	60	3/4	300-1100	2	4.0	5.0	15
6024ST	208/240	1	60	3/4	300-1100	2	4.4	6	15

4.7 BLOWER MOTOR ELECTRICAL DATA (-)H2V

(-)H2V	HP	Voltage	Phase	Hertz	RPM	Circuit AMPS	Minimum Circuit Ampacity	Max. Circuit Protector
2421HT	1/3	208/230	1	60	300-1100	1.7	4.0	15
3624HT	3/4	208/230	1	60	300-1100	4.9	9.0	15
4824HT	3/4	208/230	1	60	300-1100	4.9	9.0	15
6024HT	3/4	208/230	1	60	300-1100	4.9	9.0	15

4.8 CONVENTIONAL 24VAC THERMOSTAT CONTROL WIRING (-)H2V

The (-)ARL/(-)ASL-series of condensing units allow the installer to use conventional 24VAC control wiring and a conventional thermostat for proper unit operation.

IMPORTANT: The preferred method of unit installation and operation is by the *Comfort Control² System™*, which allows access to the fault history of the system. This diagnostic information is not available when the (-)ARL/(-)ASL unit is using a conventional thermostat. Reference section 7.1 *Comfort Control² System™* Control Wiring.

Thermostat control wiring requires a minimum of seven (7) wires for proper unit operation:

- R – 24VAC
- C – 24VAC common
- G – Constant Fan
- W1 – First stage electric heat
- W2 – Second stage electric heat
- Y1 – First stage operation
- Y2 – Second stage operation

Optional wiring:

- ODD – On demand humidification

NOTE: W1 and W2 may be jumpered together to energize all the electric heat when a call for electric heat is received if warmer supply air is desired.

NOTE: When using 24VAC thermostat control wiring, the serial communicating control will ignore any inputs to Data wire 1 and Data wire 2.

IMPORTANT: Class 2 low voltage control wire should not be run in conduit with power wiring and must be separated from power wiring, unless Class 1 wire of proper voltage rating is used.

Low voltage control wiring should be 18 AWG color-coded (105°C minimum). For lengths longer than 100 ft., 16 AWG wire should be used.

Low voltage control connections are made by extending wires from top of air handler using wire nuts.

See wiring diagrams attached to indoor and outdoor sections to be connected

Do not leave excess field control wiring inside unit, pull excess control wire to outside of unit and provide strain relief for field wiring on inside of cabinet where wiring penetrates cabinet.

Make sure, after installation, separation of control wiring and power wiring has been maintained.

4.9 ELECTRIC HEAT ELECTRICAL DATA (-)H1V

Installation of the UL Listed original equipment manufacturer provided heater kits listed in the following table is recommended for all auxiliary heating requirements.

HIGH KW ELECTRIC HEAT ELECTRICAL DATA: (-)H1V

AIR-HANDLER MODEL (-)H1V	HEATER MODEL NO.	HEATER KW 208/240V	PH/HZ	NO. ELEMENTS - KW PER	TYPE SUPPLY CIRCUIT SINGLE CIRCUIT MULTIPLE CIRCUIT	CIRCUIT AMPS.	MOTOR AMPACITY	MINIMUM CIRCUIT AMPACITY	MAXIMUM CIRCUIT PROTECTION
2417ST	RXBH-17?03J	2.25/3.0	1/60	1-3.0	SINGLE	10.8/12.5	2.2	17/19	20/20
	RXBH-1724?05J	3.6/4.8	1/60	1-4.8	SINGLE	17.3/20.0	2.2	25/28	25/30
	RXBH-1724?07J	5.4/7.2	1/60	2-3.6	SINGLE	26.0/30.0	2.2	36/41	40/45
	RXBH-1724?10J	7.2/9.6	1/60	2-4.8	SINGLE	34.6/40.0	2.2	46/53	50/60
	RXBH-1724A13J	9.4/12.5	1/60	3-4.17	SINGLE	45.1/52.1	2.2	60/68	60/70
		3.1/4.2	1/60	1-4.17	MULTIPLE CKT 1	15.0/17.4	2.2	22/25	25/25
		6.3/8.3	1/60	2-4.17	MULTIPLE CKT 2	30.1/34.7	0	38/44	40/45
	RXBH-1724A07C	5.4/7.2	3/60	3-2.4	SINGLE	15.0/17.3	2.2	22/25	25/25
RXBH-1724A10C	7.2/9.6	3/60	3-3.2	SINGLE	20.0/23.1	2.2	28/32	30/35	
RXBH-1724A13C	9.4/12.5	3/60	3-4.17	SINGLE	26.1/30.1	2.2	36/41	40/45	
3617ST	RXBH-17?03J	2.25/3.0	1/60	1-3.0	SINGLE	10.8/12.5	3.1	18/20	20/20
	RXBH-1724?05J	3.6/4.8	1/60	1-4.8	SINGLE	17.3/20.0	3.1	26/29	30/30
	RXBH-1724?07J	5.4/7.2	1/60	2-3.6	SINGLE	26.0/30.0	3.1	37/42	40/45
	RXBH-1724?10J	7.2/9.6	1/60	2-4.8	SINGLE	34.6/40.0	3.1	48/54	50/60
	RXBH-1724A13J	9.4/12.5	1/60	3-4.17	SINGLE	45.1/52.1	3.1	61/69	70/70
		3.1/4.2	1/60	1-4.17	MULTIPLE CKT 1	15.0/17.4	3.1	23/26	25/30
		6.3/8.3	1/60	2-4.17	MULTIPLE CKT 2	30.1/34.7	0	38/44	40/45
	RXBH-1724A15J	10.8/14.4	1/60	3-4.8	SINGLE	51.9/60.0	3.1	69/79	70/80
		3.6/4.8	1/60	1-4.8	MULTIPLE CKT 1	17.3/20.0	3.1	26/29	30/30
		7.2/9.6	1/60	2-4.8	MULTIPLE CKT 2	34.6/40.0	0	44/50	45/50
	RXBH-1724A18J	12.8/17.0	1/60	3-5.68	SINGLE	61.6/70.8	3.1	81/93	90/100
		4.3/5.7	1/60	1-5.68	MULTIPLE CKT 1	20.5/23.6	3.1	30/34	30/35
		8.5/11.3	1/60	2-5.68	MULTIPLE CKT 2	41.1/47.2	0	52/59	60/60
	RXBH-1724A07C	5.4/7.2	3/60	3-2.4	SINGLE	15.0/17.3	3.1	23/26	25/30
	RXBH-1724A10C	7.2/9.6	3/60	3-3.2	SINGLE	20.0/23.1	3.1	29/33	30/35
	RXBH-1724A13C	9.4/12.5	3/60	3-4.17	SINGLE	26.1/30.1	3.1	37/42	40/45
RXBH-1724A15C	10.8/14.4	3/60	3-4.8	SINGLE	30.0/34.6	3.1	42/48	45/50	
RXBH-1724A18C	12.8/17.0	3/60	3-5.68	SINGLE	35.5/41.0	3.1	49/56	50/60	
3621MT 4821ST	RXBH-1724?05J	3.6/4.8	1/60	1-4.8	SINGLE	17.3/20.0	4.0	27/30	30/30
	RXBH-1724?07J	5.4/7.2	1/60	2-3.6	SINGLE	26.0/30.0	4.0	38/43	40/45
	RXBH-1724?10J	7.2/9.6	1/60	2-4.8	SINGLE	34.6/40.0	4.0	49/55	50/60
	RXBH-1724A15J	10.8/14.4	1/60	3-4.8	SINGLE	51.9/60.0	4.0	70/80	70/80
		3.6/4.8	1/60	1-4.8	MULTIPLE CKT 1	17.3/20.0	4.0	27/30	30/30
		7.2/9.6	1/60	2-4.8	MULTIPLE CKT 2	34.6/40.0	0.0	44/50	45/50
	RXBH-1724A18J	12.8/17.0	1/60	4-4.26	SINGLE	61.6/70.8	4.0	82/94	90/100
		6.4/8.5	1/60	2-4.26	MULTIPLE CKT 1	30.8/35.4	4.0	44/50	45/50
		6.4/8.5	1/60	2-4.26	MULTIPLE CKT 2	30.8/35.4	0.0	39/45	40/45
	RXBH-24A20J (3½, 4-ton only)	14.4/19.2	1/60	4-4.8	SINGLE	69.2/80	4.0	92/105	100/110
		7.2/9.6	1/60	2-4.8	MULTIPLE CKT 1	34.6/40.0	4.0	49/55	50/60
		7.2/9.6	1/60	2-4.8	MULTIPLE CKT 2	34.6/40.0	0.0	44/50	45/50
	RXBH-24A25J (4-ton only)	18.0/24.0	1/60	6-4.0	SINGLE	86.4/99.9	4.0	113/130	125/150
		6.0/8.0	1/60	2-4.0	MULTIPLE CKT 1	28.8/33.3	4.0	42/47	45/50
		6.0/8.0	1/60	2-4.0	MULTIPLE CKT 2	28.8/33.3	0.0	36/42	40/45
		6.0/8.0	1/60	2-4.0	MULTIPLE CKT 3	28.8/33.3	0.0	36/42	40/45
	RXBH-1724A07C	5.4/7.2	3/60	3-2.4	SINGLE	15.0/17.3	4.0	24/27	25/30
	RXBH-1724A10C	7.2/9.6	3/60	3-3.2	SINGLE	20.0/23.1	4.0	30/34	30/35
	RXBH-1724A15C	10.8/14.4	3/60	3-4.8	SINGLE	30.0/34.6	4.0	43/49	45/50
	RXBH-1724A18C	12.8/17.0	3/60	3-2.84	SINGLE	35.6/41.0	4.0	50/57	50/60
	RXBH-24A20C* (3½, 4-ton only)	14.4/19.2	3/60	3-3.2	SINGLE	40.0/46.2	4.0	55/63	60/70
		7.2/9.6	3/60	3-3.2	MULTIPLE CKT 1	20.0/23.1	4.0	30/34	30/35
		7.2/9.6	3/60	3-3.2	MULTIPLE CKT 2	20.0/23.1	0.0	25/29	25/30
	RXBH-24A25C* (4-ton only)	18.0/24.0	3/60	6-4.0	SINGLE	50.0/57.8	4.0	68/78	70/80
9.0/12.0		3/60	3-4.0	MULTIPLE CKT 1	25.0/28.9	4.0	37/42	40/45	
9.0/12.0		3/60	3-4.0	MULTIPLE CKT 2	25.0/28.9	0.0	32/37	35/40	

4.9 ELECTRIC HEAT ELECTRICAL DATA: (-)H1V - continued

AIR-HANDLER MODEL (-)H1V	HEATER MODEL NO.	HEATER KW 208/240V	PH/HZ	NO. ELEMENTS - KW PER	TYPE SUPPLY CIRCUIT SINGLE CIRCUIT MULTIPLE CIRCUIT	CIRCUIT AMPS.	MOTOR AMPACITY	MINIMUM CIRCUIT AMPACITY	MAXIMUM CIRCUIT PROTECTION
4824ST 6024ST	RXBH-1724?05J	3.6/4.8	1/60	1-4.8	SINGLE	17.3/20.0	4.4	28/31	30/35
	RXBH-1724?07J	5.4/7.2	1/60	2-3.6	SINGLE	26.0/30.0	4.4	38/43	40/45
	RXBH-1724?10J	7.2/9.6	1/60	2-4.8	SINGLE	34.6/40.0	4.4	49/56	50/60
	RXBH-1724A15J	10.8/14.4	1/60	3-4.8	SINGLE	51.9/60.0	4.4	71/81	80/90
	RXBH-1724A15J	3.6/4.8	1/60	1-4.8	MULTIPLE CKT 1	17.3/20.0	4.4	28/31	30/35
		7.2/9.6	1/60	2-4.8	MULTIPLE CKT 2	34.6/40.0	0	44/50	45/50
	RXBH-1724A18J	12.8/17	1/60	4-4.26	SINGLE	61.6/70.8	4.4	83/94	90/100
	RXBH-1724A18J	6.4/8.5	1/60	2-4.26	MULTIPLE CKT 1	30.8/35.4	4.4	44/50	45/50
		6.4/8.5	1/60	2-4.26	MULTIPLE CKT 2	30.8/35.4	0	39/45	40/45
	RXBH-24A20J	14.4/19.2	1/60	4-4.8	SINGLE	69.2/80	4.4	93/106	100/110
	RXBH-24A20J	7.2/9.6	1/60	2-4.8	MULTIPLE CKT 1	34.6/40.0	4.4	49/56	50/60
		7.2/9.6	1/60	2-4.8	MULTIPLE CKT 2	34.6/40.0	0	44/50	45/50
	RXBH-24A25J	18.0/24.0	1/60	6-4.0	SINGLE	86.4/99.9	4.4	114/131	125/150
	RXBH-24A25J	6.0/8.0	1/60	2-4.0	MULTIPLE CKT 1	28.8/33.3	4.4	42/48	45/50
		6.0/8.0	1/60	2-4.0	MULTIPLE CKT 2	28.8/33.3	0	36/42	40/45
		6.0/8.0	1/60	2-4.0	MULTIPLE CKT 3	28.8/33.3	0	36/42	40/45
	RXBH-24A30J (1800 CFM only)	21.6/28.8	1/60	6-4.8	SINGLE	103.8/120.	4.4	136/156	150/175
	RXBH-24A30J (5-ton only) (1800 CFM only)	7.2/9.6	1/60	2-4.8	MULTIPLE CKT 1	34.6/40.0	4.4	49/56	50/60
		7.2/9.6	1/60	2-4.8	MULTIPLE CKT 2	34.6/40.0	0	44/50	45/50
		7.2/9.6	1/60	2-4.8	MULTIPLE CKT 3	34.6/40.0	0	44/50	45/50
	RXBH-1724A07C	5.4/7.2	3/60	3-2.4	SINGLE	15.0/17.3	4.4	25/28	25/30
	RXBH-1724A10C	7.2/9.6	3/60	3-3.2	SINGLE	20.0/23.1	4.4	31/35	35/35
	RXBH-1724A15C	10.8/14.4	3/60	3-4.8	SINGLE	30.0/34.6	4.4	43/49	45/50
	RXBH-1724A18C	12.8/17.0	3/60	3-2.84	SINGLE	35.6/41.0	4.4	50/57	50/60
	RXBH-24A20C*	14.4/19.2	3/60	3-3.2	SINGLE	40.0/46.2	4.4	56/64	60/70
		7.2/9.6	3/60	3-3.2	MULTIPLE CKT 1	20.0/23.1	4.4	31/35	35/35
		7.2/9.6	3/60	3-3.2	MULTIPLE CKT 2	20.0/23.1	0	25/29	25/30
	RXBH-24A25C*	18.0/24.0	3/60	6-4.0	SINGLE	50.0/57.8	4.4	68/78	70/80
	RXBH-24A25C	9.0/12.0	3/60	3-4.0	MULTIPLE CKT 1	25.0/28.9	4.4	37/42	40/45
		9.0/12.0	3/60	3-4.0	MULTIPLE CKT 2	25.0/28.9	0	32/37	35/40
	RXBH-24A30C* (1800 CFM only)	21.6/28.8	3/60	6-4.8	SINGLE	60.0/69.4	4.4	81/93	90/100
	RXBH-24A30C (5-ton only) (1800 CFM only)	10.8/14.4	3/60	3-4.8	MULTIPLE CKT 1	30.0/34.7	4.4	43/50	45/50
10.8/14.4		3/60	3-4.8	MULTIPLE CKT 2	30.0/34.7	0	38/44	40/45	

NOTES:

- * Values only. No single point kit available.
- Electric heater BTUH - (heater watts + motor watts) x 3.414 (see airflow table for motor watts.)
- Supply circuit protective devices may be fuses or "HACR" type circuit breakers.
- Largest motor load is included in single circuit and multiple circuit 1.
- If non-standard fuse size is specified, use next size larger fuse size.
- J Voltage (230V) single phase air handler is designed to be used with single or three phase 230 volt electric heaters. In the case of connecting 3-phase power to the air handler terminal block without the heater, bring only two leads to the terminal block. Cap, insulate and fully secure the third lead.
- If the kit is listed under both single and multiple circuits, the kit is shipped from factory as multiple circuits. For single phase application, Jumper bar kit RXBJ-A21 and RXBJ-A31 can be used to convert multiple circuits to a single supply circuit. Refer to Accessory Section for details.
- The airflow for continuous fan is set 50% of the cooling airflow.
- ?Heater kits connection type. A=Breaker B=Terminal Block C=Disconnect Pull Out

4.10 ELECTRIC HEAT ELECTRICAL DATA (-)H2V

Installation of the UL Listed original equipment manufacturer provided heater kits listed in the table below is recommended for all auxiliary heating requirements.

Model Size (-)H2V	Manufacturer Model Number	Type Supply Circuit	Voltage	PH/HZ	Heater kW	Heater AMPS	Motor Ampacity	Maximum Circuit Protection	Minimum Circuit Ampacity
2421HT	RXBH-1724?05J	Single	208/240	1/60	3.6/4.8	17.3/20.0	1.7	25/30	24/28
	RXBH-1724?07J	Single	208/240	1/60	5.4/7.2	26.0/30.0	1.7	35/40	35/40
	RXBH-1724?10J	Single	208/240	1/60	7.2/9.6	34.6/40.0	1.7	50/60	46/53
3624HT	RXBH-1724?05J	Single	208/240	1/60	3.6/4.8	17.3/20.0	4.9	30/35	28/32
	RXBH-1724?07J	Single	208/240	1/60	5.4/7.2	26.0/30.0	4.9	40/45	39/44
	RXBH-1724?10J	Single	208/240	1/60	7.2/9.6	34.6/40.0	4.9	50/60	50/57
	RXBH-1724A15J	Single	208/240	1/60	10.8/14.4	51.9/60.0	4.9	80/90	72/82
		MULTI. CKT 1	208/240	1/60	3.6/4.8	17.3/20.0	4.9	30/35	28/32
		MULTI. CKT 2	208/240	1/60	7.2/9.6	34.6/40.0	0	45/50	44/50
	RXBH-1724A18J	Single	208/240	1/60	12.8/17	61.6/70.8	4.9	90/100	84/95
		MULTI. CKT 1	208/240	1/60	6.4/8.5	30.8/35.4	4.9	45/60	45/51
		MULTI. CKT 2	208/240	1/60	6.4/8.5	30.8/35.4	0	40/45	39/45
4824HT	RXBH-1724?05J	Single	208/240	1/60	3.6/4.8	17.3/20.0	4.9	30/35	28/32
	RXBH-1724?07J	Single	208/240	1/60	5.4/7.2	26.0/30.0	4.9	40/45	39/44
	RXBH-1724?10J	Single	208/240	1/60	7.2/9.6	34.6/40.0	4.9	50/60	50/57
	RXBH-1724A15J	Single	208/240	1/60	10.8/14.4	51.9/60.0	4.9	80/90	72/82
		MULTI. CKT 1	208/240	1/60	3.6/4.8	17.3/20.0	4.9	30/35	28/32
		MULTI. CKT 2	208/240	1/60	7.2/9.6	34.6/40.0	0	45/50	44/50
	RXBH-1724A18J	Single	208/240	1/60	12.8/17	61.6/70.8	4.9	90/100	84/95
		MULTI. CKT 1	208/240	1/60	6.4/8.5	30.8/35.4	4.9	45/60	45/51
		MULTI. CKT 2	208/240	1/60	6.4/8.5	30.8/35.4	0	40/45	39/45
	RXBH-24A20J	Single	208/240	1/60	14.4/19.2	69.2/80.0	4.9	100/110	93/107
		MULTI. CKT 1	208/240	1/60	7.2/9.6	34.6/40.0	4.9	50/60	50/57
		MULTI. CKT 2	208/240	1/60	7.2/9.6	34.6/40.0	0	45/50	44/50
	RXBH-24A25J (4-ton only)	Single	208/240	1/60	18.0/24.0	87.0/99.9	4.9	125/150	115/132
		MULTI. CKT 1	208/240	1/60	6.0/8.0	29.0/33.3	4.9	45/50	43/48
		MULTI. CKT 2	208/240	1/60	6.0/8.0	29.0/33.3	0	40/45	37/42
MULTI. CKT 3		208/240	1/60	6.0/8.0	29.0/33.3	0	40/45	37/42	
6024HT	RXBH-1724?07J	Single	208/240	1/60	5.4/7.3	26.0/30.0	4.9	40/45	39/44
	RXBH-1724?10J	Single	208/240	1/60	5.4/7.2	26.0/30.0	4.9	40/45	39/44
	RXBH-1724A15J	Single	208/240	1/60	10.8/14.4	51.9/60.0	4.9	80/90	72/82
		MULTI. CKT 1	208/240	1/60	3.6/4.8	17.3/20.0	4.9	30/35	28/32
		MULTI. CKT 2	208/240	1/60	7.2/9.6	34.6/40.0	0	45/50	44/50
	RXBH-1724A18J	Single	208/240	1/60	12.8/17	61.6/70.8	4.9	90/100	84/95
		MULTI. CKT 1	208/240	1/60	6.4/8.5	30.8/35.4	4.9	45/60	45/51
		MULTI. CKT 2	208/240	1/60	6.4/8.5	30.8/35.4	0	40/45	39/45
	RXBH-24A20J	Single	208/240	1/60	14.4/19.2	69.2/80.0	4.9	100/110	93/107
		MULTI. CKT 1	208/240	1/60	7.2/9.6	34.6/40.0	4.9	50/60	50/57
		MULTI. CKT 2	208/240	1/60	7.2/9.6	34.6/40.0	0	45/50	44/50
		Single	208/240	1/60	18.0/24.0	87.0/99.9	4.9	125/150	115/132
	RXBH-24A25J	MULTI. CKT 1	208/240	1/60	6.0/8.0	29.0/33.3	4.9	45/50	43/48
		MULTI. CKT 2	208/240	1/60	6.0/8.0	29.0/33.3	0	40/45	37/42
		MULTI. CKT 3	208/240	1/60	6.0/8.0	29.0/33.3	0	40/45	37/42
RXBH-24A30J	Single	208/240	1/60	21.6/28.8	103.8/120.0	4.9	136/156	150/175	
RXBH-24A30J	MULTI. CKT 1	208/240	1/60	7.2/9.6	34.6/40.0	4.9	49/56	50/60	
	MULTI. CKT 2	208/240	1/60	2-4.8	34.6/40.0	0	44/50	45/50	
	MULTI. CKT 3	208/240	1/60	7.2/9.6	34.6/40.0	0	44/50	45/50	

NOTES:

- Supply circuit protective devices may be fuses or "HACR" type circuit breakers.
- Largest motor load is included in single circuit and multiple circuit 1.
- If non-standard fuse size is specified, use next size larger fuse size.
- J Voltage (230V) signal phase air handler is designed to be used with single or three phase 230 volt electric heaters. In the case of connecting 3-phase power to the air handler terminal block without the heater, bring only two leads to the terminal block. Cap, insulate and fully secure the third lead.
- ?Heater Kit Connection Type A=Breaker B=Terminal Block C=Pullout Disconnect

4.11 HEATER KIT SUPPLEMENTAL INFORMATION (-)H1V & (-)H2V

MFD: MO./YEAR 01/2006
FRQ: MO./JANNE

AIR CONDITIONING DIVISION

MADE IN THE U.S.A.
FAIT DANS L'USA

MODEL/MODELE # SERIAL/EN SERIE # M0106 38751

VOLTS 208/240 PH/HZ 1/60 MOTOR HP./F.L.A. 1/2 4.1
MOTEUR PSC/F.L.A.

ATTENTION: MARK HEATER INSTALLED/
L'APPAREIL DE CHAUFFAGE DE MARQUE A INSTALLER

HEATER MODEL/MODELE D'APPAREIL DE CHAUFFAGE	TYPE SUPPLY CIRCUIT/TAPER-LE-CIRCUIT DE PROVISION	VOLTAGE/TENSION	PHASE	KW	HEATER AMPS/AMPLIS D'APPAREIL DE CHAUFFAGE	MOTOR AMPS/LES AMPLIS MOTEURS	MAXIMUM OVERCURRENT PROTECTION LA PROTECTION MAXIMUM DE OVERCURRENT	MINIMUM BRANCH CIRCUIT AMPCITY/MINIMUM DE CIRCUIT DE BRANCHE
NO HEAT				0.0		4.1	75	5.2
RXBH-24A05J	SINGLE	208/240	1/60	3.6/4.8	17.3/20.0	6.0	30/35	30/33
RXBH-24A07J	SINGLE	208/240	1/60	5.4/7.2	26.0/30.0	6.0	40/45	40/45
RXBH-24A10J	SINGLE	208/240	1/60	7.2/9.6	34.6/40.0	6.0	60/60	51/58
RXBH-24A15J	SINGLE	208/240	1/60	10.8/14.4	51.9/60.0	6.0	80/90	73/83
RXBH-24A15J	MULTI CKT 1	208/240	1/60	3.6/4.8	17.3/20.0	6.0	30/35	30/33
RXBH-24A15J	MULTI CKT 2	208/240	1/60	7.2/9.6	34.6/40.0	0.0	45/50	44/50
RXBH-24A18J	SINGLE	208/240	1/60	12.8/17.0	61.2/70.8	6.0	90/100	84/96
RXBH-24A18J	MULTI CKT 1	208/240	1/60	6.4/8.5	30.8/35.4	6.0	50/60	46/52
RXBH-24A18J	MULTI CKT 2	208/240	1/60	6.4/8.5	30.8/35.4	0.0	40/45	39/45
RXBH-24A20J	SINGLE	208/240	1/60	14.4/19.2	69.2/80.0	6.0	100/110	94/108
RXBH-24A20J	MULTI CKT 1	208/240	1/60	7.2/9.6	34.6/40.0	6.0	60/60	51/58
RXBH-24A20J	MULTI CKT 2	208/240	1/60	7.2/9.6	34.6/40.0	0.0	45/50	44/50
RXBH-24A07C	SINGLE	208/240	3/60	5.4/7.2	15.0/17.3	6.0	30/30	27/30
RXBH-24A10C	SINGLE	208/240	3/60	7.2/9.6	20.0/23.1	6.0	35/40	33/37
RXBH-24A15C	SINGLE	208/240	3/60	10.8/14.4	30.0/34.6	6.0	45/60	45/51
RXBH-24A15C	SINGLE	208/240	3/60	12.4/17.0	35.6/41.0	6.0	60/60	52/59
RXBH-24A18C	MULTI CKT 1	208/240	3/60	6.4/8.5	17.8/20.5	6.0	30/35	30/34
RXBH-24A18C	MULTI CKT 2	208/240	3/60	6.4/8.5	17.8/20.5	0.0	25/30	23/26
RXBH-24A20C	SINGLE	208/240	3/60	14.2/19.2	40.0/46.2	6.0	60/70	58/66
RXBH-24A20C	MULTI CKT 1	208/240	3/60	7.2/9.6	20.0/23.1	6.0	35/40	33/37
RXBH-24A20C	MULTI CKT 2	208/240	3/60	7.2/9.6	20.0/23.1	0.0	25/30	25/29

S = SINGLE CIRCUIT/CIRCUIT SIMPLE M = MULTIPLE CIRCUIT/CIRCUIT MULTIPLE

INDOOR BLOWER MOTOR LOAD INCLUDED IN CIRCUIT # 1 OR TOTAL SUPPLY WIRE MUST BE RATED AT 75°C MINIMUM COPPER CONDUCTORS ONLY. TEST EXTERNAL STATIC RANGE .1 TO 5 IN. W.C. (HEAT PUMP & ELECTRIC HEAT).

UNITS WITH ELECTRIC HEATERS: CLEARANCE TO COMBUSTIBLE MATERIAL TO BE 0 IN. TO UNIT CASING AND 0 IN. TO PLENUM AND DUCT FOR FIRST 36 IN. MODELS HAVE INTEGRAL CIRCUIT BREAKERS WHICH PROVIDE SUPPLEMENTARY OVERCURRENT PROTECTION AND SERVE AS A MAINTENANCE "DISCONNECT". SUPPLY CIRCUIT NOT TO EXCEED 120 VOLTS TO GROUND ON SINGLE PHASE UNITS. REPLACE LINE SIDE BREAKER COVER(S) AFTER MAKING WIRING CONNECTIONS TO BREAKER(S). IF BLOWER-CONTROL ASSEMBLY REQUIRES REMOVAL, SEE "WARNING HAZARDOUS VOLTAGE".

CHARGEMENT DU MOTEUR SOUFFLEUR INTERNE INCLUS DANS LE CIRCUIT # 1 OU CAPACITE DU CABLAGE D'ALIMENTATION TOTAL DOIT ETRE DE 75C DU MINIMUM DE CONDUCTEURS DE CUIVRE SEULEMENT. TESTER L'INTERVALLE STATIQUE EXTERNE : 1 A 5 PO W.C (THERMOPOMPE ET CHAUFFAGE ELECTRIQUE)

UNITES AVEC CHAUFFAGES ELECTRIQUES : LE DEGAGEMENT AUX MATIERES COMBUSTIBLES DOIT ETRE DE 0 po AU BOITIER DE L'UNITE ET DE 0 po AU PLENUM ET CONDUIT POUR LES 36 PREMIERS po. LES MODELES DISPOSENT DE DISJONCTEURS INTEGRES QUI FOURNISSENT UNE PROTECTION SUPPLEMENTAIRE DE SURINTENSITE DE COURANT ET SERVENT DE « SECTIONNEUR » D'ENTRETIEN. LE CIRCUIT D'ALIMENTATION NE DOIT PAS DEPASSER 120 VOLTS JUSQU'AU SOL SUR DES UNITES MONOPHASEES. REMPLACER LE(S) COUVERCLE(S) DU DISJONCTEUR DU COTE SECTEUR APRES AVOIR EFFECTUE LA CONNEXION DES CABLAGES AU(X) DISJONCTEUR(S). SI L'ASSEMBLAGE DE CONTROLE DU VENTILATEUR A BESOIN D'ETRE DESASSEMBLE, CONSULTER "AVERTISSEMENT DE TENSION DANGEREUSE"

Contractor should "mark or check" the left column for the kit installed

If a heater kit is listed both Single and Multi-circuit, the kit is shipped as a Multi-circuit and will require a single point kit

These are the required maximum and minimum circuit breaker sizes for overcurrent protection and should not be confused with the size of the breakers installed in the heater kit.

Only listed kits can be applied

Heater Kit Supplemental Information: What allows the manufacturer to use standard Circuit Breakers up to 60 amps inside the air handler, when using an approved Heater Kit?

National Electric Code (Section 424-22b) and our UL requirements allow us to subdivide heating element circuits, of less than 48 amps, using breakers of not more than 60 amps and, additionally by, NEC 424-3b, a rating not less than 125 percent of the load and NEC 424-22c, which describes the supplementary overcurrent protection required to be factory-installed within, or on the heater. The breakers in the heater kit are not, and have never been, by NEC, intended to protect power wiring leading to the air handler unit. The breakers in the heating kit are for short circuit protection. All internal unit wiring, where the breakers apply, has been UL approved for short circuit protection.

Ampacity, (not breaker size), determines supply circuit wire size. The ampacity listed on the unit rating plate and the Maximum and Minimum circuit breaker size (noted above) or in the units specification sheet or installation instructions provides the information to properly select wire and circuit breaker/protector size. The National Electric Code (NEC) specifies that the supply or branch circuit must be protected at the source.

5.0 AIR HANDLER EQUIPPED WITH ECM MOTOR INTERFACE CONTROL BOARD (-)H1V

IMPORTANT: Factory switch settings are all “OFF” except switch 9, which is “ON”.

5.1 ECM MOTOR INTERFACE CONTROL AND SETTINGS

IMPORTANT: Disconnect power to air handler when changing DIP switch positions. Even if blower is not operating, the motor will not recognize changes in DIP switch positions until unit power is removed and then restored.

The (-)H1V series air handlers have ECM blower motors, which deliver a constant level of airflow over a wide range of external static pressures (up to 1.0" W.C.). The interface board provides the required communications between the thermostat and the ECM blower motor. The (-)H1V series of air handlers feature:

- An automotive-style ATC blade fuse for transformer protection (3 amp).
- An on-board LED to indicate blower CFM.

TABLE 1
SWITCH FUNCTIONS

Switch	Function
1 & 2	Cooling Airflow Settings
3 & 4	Cooling Airflow Adjustment
5 & 6	Heating Airflow Settings
7 & 8	Cooling Delay Profiles
9 & 10	On-Demand Dehumidification – Active & Passive

There is a bank of 10 DIP switches on the interface board that define the operation of the ECM motor (see Table 1).

Refer to Figure 23 for switch identification and factory default settings.

NOTE: All units are shipped from the factory on High Airflow.

FIGURE 23
ECM MOTOR FACTORY SETTINGS

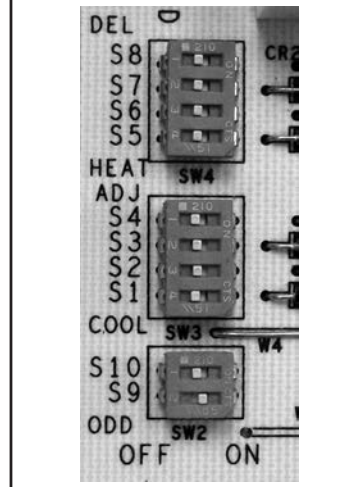

5.2 USING THE ON-BOARD LED TO DETERMINE BLOWER CFM (-)H1V

The (-)H1V interface board LED (see Figure 24) indicates blower output by flashing one (1) second for every 100 CFM of airflow. The LED will pause 1/10 second between each flash. After the blower CFM has been displayed, the LED will illuminate dimly for 10 seconds before repeating the sequence. (See Table 2.)

NOTE: If airflow is not a multiple of 100 CFM, the last LED flash is a fraction of a second of 100 CFM. (Airflow must be verified, flash code is what is set.)

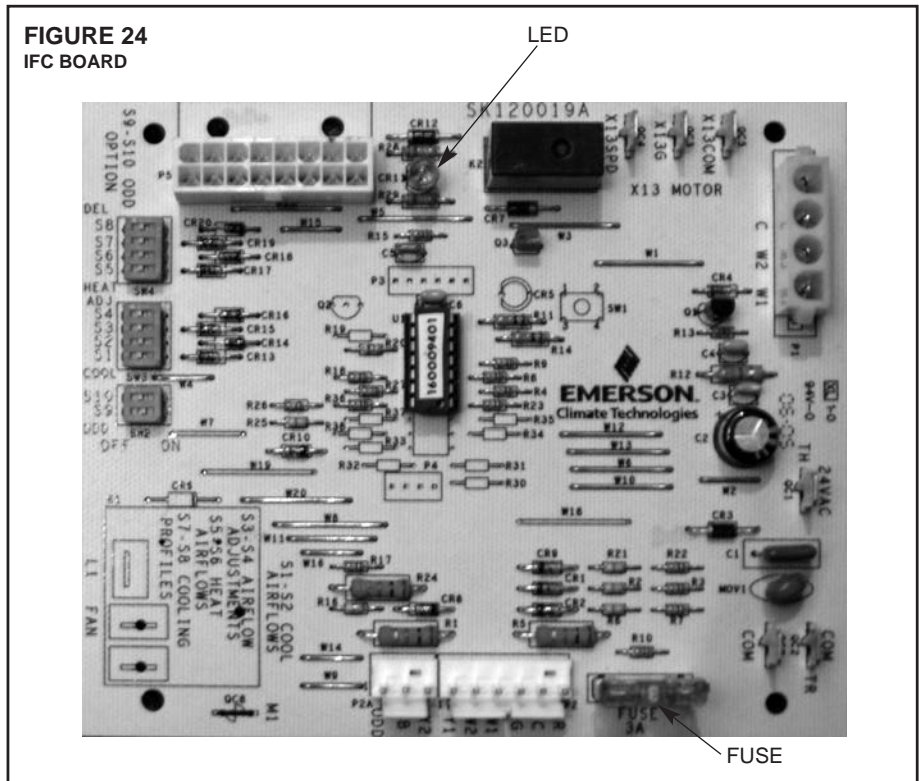

TABLE 2
LED FLASH CODES

INTERFACE BOARD DIP SWITCH SETTINGS	SOME EXAMPLES OF LED OUTPUT
1200 CFM	<ul style="list-style-type: none"> Flashes 12 times Illuminate dimly 10 seconds, repeat sequence
600 CFM	<ul style="list-style-type: none"> Flashes 6 times Illuminate dimly 10 seconds, repeat sequence
950 CFM	<ul style="list-style-type: none"> Flashes 9 times, flash once for 1/2 second Illuminate dimly 10 seconds, repeat sequence

5.3 COOLING AND HEAT PUMP HEATING MODE AIRFLOW SETTINGS (-)H1V (SEE FIGURE 25)

The (-)H1V-series of air handlers allow a wide range of airflow settings for cooling and heat pump operation. These airflow settings are selected via DIP switches 1 and 2 on the interface board. DIP switches 1 and 2 allow the user to tailor the airflow for the particular installation.

NOTE: Cooling/heating air-flow adjustments using DIP switches 3 and 4 also affect electric heat airflow on (-)H1V air-handlers.

FIGURE 25
FACTORY AIRFLOW SETTINGS FOR SWITCHES 1 AND 2 (-)H1V

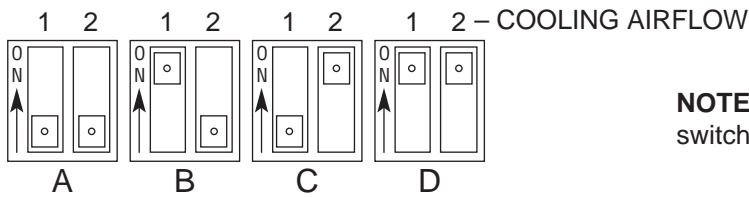

NOTE: With no dehumidification; switch 9 “ON” (factory default)

SELECTION (ONE OF THE PAIRS)	SWITCH 1 AND 5 POSITION	SWITCH 2 AND 6 POSITION	COOLING/HEATING AIRFLOW CABINET SIZE/COOLING CAPACITY							
			(-)H1V 17/ 1½ & 2 TON		(-)H1V 17/ 2½ & 3 TON		(-)H1V 21/ 3½ & 4 TON		(-)H1V 24/ 4 & 5 TON	
			Y1	Y2	Y1	Y2	Y1	Y2	Y1	Y2
A	OFF	OFF	800	800	1200	1200	1600	1600	1800	1800
B	ON	OFF	800	800	1200	1200	1600	1600	1800	1800
C	OFF	ON	600	600	1000	1000	1400	1400	1600	1600
D	ON	ON	600	600	1000	1000	1400	1400	1600	1600

5.4 COOLING/HEATING AIRFLOW ADJUSTMENTS (-)H1V (SEE FIGURE 25)

Cooling/heating airflow may be adjusted +10% or –10% from nominal airflow using switches 3 and 4.

Refer to Figure 26 for switch positions to achieve the desired adjustments in airflow.

NOTE: Continuous fan speed is NOT affected by switches 3 and 4 selections. Continuous fan speed is 50% of the selected cooling speed for switches 1 and 2.

IMPORTANT: The use of On Demand Dehumidification overrides the cooling airflow adjustments when high humidity is detected by a dehumidifying thermostat or humidistat when connected to the ODD wire (See Figure 17). Refer to the Cooling Mode Dehumidification section for more information.

5.5 ELECTRIC HEAT AIRFLOW SETTINGS/ADJUSTMENTS (-)H1V

DIP switches 5 and 6 control electric heat air-flow levels on (-)H1V air-handlers.

FIGURE 26
COOLING AIRFLOW ADJUSTMENTS (-)H1V

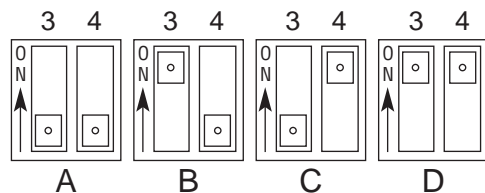

SELECTION	SWITCH 3 POSITION	SWITCH 4 POSITION	COOLING AIRFLOW ADJUSTMENT
A	OFF	OFF	NONE
B	ON	OFF	10%
C	OFF	ON	-10%
D	ON	ON	NONE

FIGURE 27
FACTORY AIRFLOW SETTINGS FOR SWITCHES 5 AND 6 (-)H1V

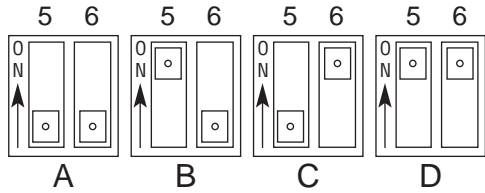

MINIMUM AIR FLOW PER kW	
3 kW to 13 kW	= 600 min. CFM
15 kW to 18 kW	= 800 min. CFM
20 kW to 25 kW	= 1400 min. CFM
30 kW	= 1800 min. CFM

SELECTION	SWITCH 5 POSITION	SWITCH 6 POSITION	ELECTRIC HEAT AIR FLOW					
			(-)H1V-2417ST	(-)H1V-3617ST	(-)H1V-3821ST	(-)H1V-4824ST	(-)H1V-4824ST	(-)H1V-6024ST
A	OFF	OFF	800	1200	1200	1600	1800	1800
B	ON	OFF	600	600	600	800	800	800
C	OFF	ON	800	1000	1000	1400	1600	1600
D	ON	ON	600	600	600	800	800	800

5.6 COOLING DELAY PROFILES (-)H1V

The (-)H1V air handlers are shipped with a default 30 second blower OFF delay profile for maximum efficiency.

IMPORTANT: Blower ON delay profiles are not used in heating mode.

5.7 COOLING MODE DEHUMIDIFICATION (-)H1V (PASSIVE: FACTORY PROGRAMMED PROFILES)

Factory board settings will provide general overall performance under average conditions. Use these Advanced Profiles to optimize performance and to add soft motor operation. Please be sure that you check for correct airflow and adjust refrigerant charge based on your Maximum Capacity and Airflow using the Factory AIRFLOW SETTINGS. Switches 1 and 2 should be set for the tonnage and airflow requirement for the system. **Advanced Airflow settings** will, in most cases, greatly reduce airflow to the system and change the system's Latent and Sensible capacity splits. The control board flashes CFM to the nearest 50 CFM calculated. **We suggest that trouble-shooting be done with switches in the factory position for verification of refrigerant charge and airflow through the duct system.**

FIGURE 28
COOLING AIRFLOW ADJUSTMENTS (-)H1V

Advanced Cooling Adjustments				
Switch 7 and 8 Settings and Characteristics				Factory
S7	on	off	on	off
S8	off	on	on	off
Moisture Removal	Highest	Good	Lowest	Standard

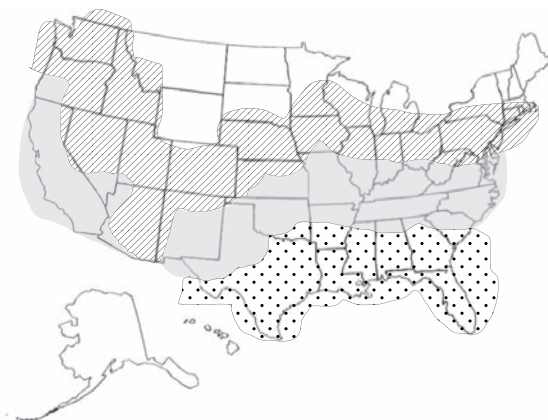

TABLE 3 (-)H1V

Pre-programmed CFM Rates		
Operating Sequence	Ramp Times	CFM Reduction
	5 minutes	18% Less
	5 to 12.5 minutes after 12.5 minutes	12% Less 100% Full
Pre-programmed CFM Rates		
Operating Sequence	Ramp Times	CFM Reduction
	3 minutes	25% Less
	3 to 8 minutes after 8 minutes	12% Less 100% Full
Pre-programmed CFM Rates		
Operating Sequence	Ramp Times	CFM Reduction
	3 minutes after 3 minutes	18% Less 100% Full

NOTE: The control is equipped with 3 preprogrammed CFM rates for moisture removal. These are selected with switches S7 and S8. Please refer to Figure 28 and Table 3 for moisture removal options.

- Multiple Switch Setting **CAUTION: Switches 7 and 8** provide dehumidification by using pre-programmed airflow profiles and airflow percentage reductions that reduce airflow based from selections using switches 3 and 4. **Exception:** If Minus 10% is selected from switches 3 and 4, the selections of 7 and 8 reduction will be from the nominal CFM selected on 1 and 2. **Multiple reductions** in airflow will occur that may adversely reduce airflow if 7 and 8 profiles are used with a humidistat or dehumidifying thermostat. **CAUTION: If a Humidistat, or a Thermostat with a Dehumidifying feature, is to be used, leave switches 7 and 8 in the FACTORY POSITIONS (both in the off position) and skip Advanced Dehumidification Profiles.**

5.8 COOLING MODE DEHUMIDIFICATION – ACTIVE (-)H1V

(Active Dehumidification: ODD senses RH% and adjusts airflow to maintain selected humidity levels.)

“On Demand Dehumidification”, ODD, terminal input allows the user to have automatic dehumidification in the cooling mode that is controlled by the user’s dehumidifying thermostat or humidistat setting. When the humidity exceeds the humidistat setting, the airflow is decreased by a preprogrammed amount. This results in higher latent capacity and increases the level of comfort.

Use of the On Demand Dehumidification feature is important with the (-)H1V air handlers. These systems typically have a latent capacity between 23% to 25% of total system capacity. On Demand Dehumidification drops cooling airflow to boost latent capacity without sacrificing total system capacity.

The interface board “ODD” terminal input is designed to be used with a dehumidifying thermostat or a traditional humidistat (see Figure 17). For proper operation, the dehumidifying thermostat or humidistat must conform to these conditions:

IMPORTANT: A humidistat can be used for dehumidification as long as it is the type where the contacts close when the humidity is low. Dehumidistat 41-25066-02 can also be used since its contacts close when the humidity is low. Other dehumidistats are not compatible with the interface board. Typical dehumidistats apply a 24V signal when humidity is high and are incompatible with the interface board.

Refer to the typical thermostat wiring section (See Figures 15-20) for recommended dehumidifying thermostats.

5.9 ON DEMAND DEHUMIDIFICATION AIRFLOW ADJUSTMENT – ACTIVE (-)H1V

Use switches 9 & 10 to lower cooling airflow as defined in Figure 29:

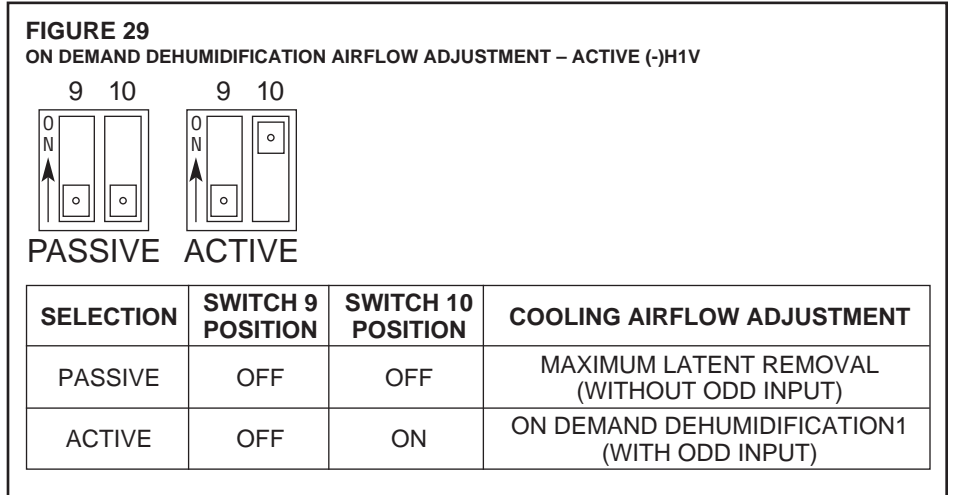

IMPORTANT: Selection A turns off the input of the ODD terminal. DO NOT USE SELECTION A WITH A DEHUMIDIFYING THERMOSTAT OR HUMIDISTAT (refer to Figure 29).

Selection C: On Demand Dehumidification (See Table 5) – Active

TABLE 4
SELECTION A EXPLANATION: MAXIMUM LATENT REMOVAL – PASSIVE (-)H1V

SWITCH POSITIONS				CABINET SIZE/COOLING CAPACITY CFM				
SWITCH 1 POSITION	SWITCH 2 POSITION	SWITCH 9 POSITION	SWITCH 10 POSITION	17/ 1½ & 2.0	17/ 2.0 & 3.0	21/ 3.0	21/ 3½ & 4.0	24/ 4.0 & 5.0
OFF	OFF	OFF	OFF	680	1020		1360	1530
ON	OFF	OFF	OFF	680	1020		1360	1530
OFF	ON	OFF	OFF	510	850		1190	1360
ON	ON	OFF	OFF	510	850		1190	1360

TABLE 5
SELECTION C EXPLANATION: ON DEMAND DEHUMIDIFICATION – ACTIVE (-)H1V

SWITCH POSITIONS				CABINET SIZE/COOLING CAPACITY				
SWITCH 1 POSITION	SWITCH 2 POSITION	SWITCH 9 POSITION	SWITCH 10 POSITION	ODD INPUT	17 / 1½ & 2.0 Y1 Y2	17 / 2.0 & 3.0 21/3.0 Y1 Y2	21 / 3½ & 4.0 Y1 Y2	24 / 4.0 & 5.0 Y1 Y2
OFF	OFF	OFF	ON	NONE	680	1020	1360	1530
				24VAC	800	1200	1600	1800
ON	OFF	OFF	ON	NONE	680	1020	1360	1530
				24VAC	800	1200	1600	1800
OFF	ON	OFF	ON	NONE	510	830	1190	1360
				24VAC	600	1000	1400	1600
ON	ON	OFF	ON	NONE	510	830	1190	1360
				24VAC	600	1000	1400	1600

TABLE 6
ODD TERMINAL (-)H1V

INDOOR AMBIENT CONDITION	INPUT TO “ODD” TERMINAL (FROM HUMIDISTAT)
HIGH HUMIDITY	Ø VAC
LOW HUMIDITY	24 VAC

This selection allows On Demand Dehumidification when using a dehumidifying thermostat or humidistat connected to the ODD wire (as shown in Figure 17). Nominal airflow is reduced by a preprogrammed amount to maximize latent removal.

IMPORTANT: A humidistat or dehumidifying thermostat MUST be connected to the ODD terminal when using this setting.

5.10 AIRFLOW PERFORMANCE (-)H1V

Airflow performance data is based on cooling performance with a coil and no filter in place. Select performance table for appropriate unit size, voltage and number of electric heaters to be used. Make sure external static applied to unit allows operation within the minimum and maximum limits shown in table below for both cooling and electric heat operation. For optimum blower performance, operate the unit in the .1 [3 mm] to 1.00 inches [25 mm] W.C. external static range. Units with coils should be applied with a minimum of .1 inch [3 mm] W.C. external static.

5.11 AIRFLOW PERFORMANCE DATA (-)H1V

Model Size (-)H1V	Nominal Cooling Capacity Tons	Motor Speed From Factory	Nominal Air-Flow CFM	Blower Size Motor H.P.	CFM Air Delivery/RPM/Watts-230 Volts (No Filter)										
					External Static Pressure-Inches W.C.										
						0.10	0.20	0.30	0.40	0.50	0.60	0.70	0.80	0.90	1.00
2417ST No Heat	1.5	High	600*	10x8 1/3 [249] 5 Speed	CFM	597	608	607	616	616	618	613	608	600	594
					RPM	522	609	673	757	815	869	938	995	1051	1097
					Watts	57	74	89	115	130	144	169	190	212	232
2417ST with 13kw Heater	1.5	High	600*	10x8 1/3 [249] 5 Speed	CFM	588	598	596	605	603	605	600	595	587	577
					RPM	536	608	723	805	864	919	989	1047	1104	1149
					Watts	65	85	100	129	145	160	186	209	233	254
2417ST No Heat	2	High	800	10x8 1/3 [249] 5 Speed	CFM	787	805	815	819	810	807	811	810	809	805
					RPM	614	682	763	818	868	917	972	1017	1070	1112
					Watts	97	113	144	167	191	209	239	259	289	311
2417ST with 13kw Heater	2	High	800	10x8 1/3 [249] 5 Speed	CFM	775	793	803	807	798	795	799	798	797	793
					RPM	630	700	783	839	891	941	997	1044	1098	1141
					Watts	111	130	165	192	219	240	275	298	332	357
3617ST No heat	2.5	High	1000*	10x8 1/2	CFM	1001	1030	1030	1035	1035	1029	1029	1029	1029	1023
					RPM	652	752	812	845	923	945	1007	1065	1090	1118
					Watts	134	166	193	212	244	266	280	320	341	357
3617ST with 18kw heat	2.5	High	1000*	10x8 1/2	CFM	980	1009	1009	1014	1014	1008	1008	1008	1008	1002
					RPM	714	814	874	907	985	1007	1069	1127	1152	1180
					Watts	176	208	235	254	286	308	322	362	383	399
3617ST No heat	3.0	High	1200	10x8 1/2	CFM	1220	1229	1229	1229	1229	1229	1238	1238	1233	1228
					RPM	732	831	875	930	981	1005	1077	1108	1156	1194
					Watts	215	253	282	314	348	362	409	426	472	496
3617ST with 18kw heat	3.0	High	1200	10x8 1/2	CFM	1199	1208	1208	1208	1208	1208	1217	1217	1212	1207
					RPM	794	893	937	992	1043	1067	1139	1170	1218	1256
					Watts	257	295	3245	356	390	404	451	468	514	538
3621MT No heat	2.5 ton	High	1000	10x10 3/4	CFM	1000	1001	1011	1009	1005	1000	996	994	970	967
					RPM	593	650	737	801	867	914	980	1026	1058	1099
					Watts	103	124	155	177	207	224	258	287	301	323
3621MT with 15kw heat	2.5 ton	High	1000	10x10 3/4	CFM	984	979	984	976	967	956	947	939	910	901
					RPM	627	689	780	849	919	971	1041	1092	1128	1174
					Watts	124	151	187	215	250	273	312	347	366	394
3621MT No heat	3.0 ton	High	1200	10x10 3/4	CFM	1175	1200	1203	1200	1200	1199	1202	1200	1197	1180
					RPM	646	740	783	851	911	958	1013	1056	1102	1144
					Watts	147	186	207	240	270	296	334	356	385	416
3621MT with 18kw heat	3.0 ton	High	1200	10x10 3/4	CFM	1159	1178	1176	1167	1162	1155	1153	1145	1137	1114
					RPM	680	779	826	899	963	1015	1074	1122	1172	1219
					Watts	168	213	239	278	313	345	388	416	450	487
4821ST No heat	3.5	High	1400*	10x10 3/4	CFM	1395	1404	1413	1413	1411	1411	1402	1391	1380	1371
					RPM	731	807	859	910	968	1016	1057	1100	1128	1158
					Watts	240	273	308	349	383	411	436	468	496	513
4821ST with 20kw heat	3.5	High	1400*	10x10 3/4	CFM	1379	1382	1386	1380	1373	1367	1353	1336	1320	1305
					RPM	765	846	902	958	1020	1073	1118	1166	1198	1233
					Watts	261	300	340	387	426	460	490	528	561	584
4821ST No heat	4.0	High	1600	10x10 3/4	CFM	1583	1583	1583	1590	1582	1566	1572	1556	1547	1539
					RPM	826	879	933	984	1025	1067	1119	1148	1176	1219
					Watts	342	375	410	454	486	523	552	585	614	616
4821ST with 25kw heat	4.0	High	1600	10x10 3/4	CFM	1567	1559	1551	1550	1534	1511	1509	1485	1468	1452
					RPM	860	919	978	1035	1082	1129	1187	1222	1255	1304
					Watts	363	403	444	495	534	577	613	653	688	697

5.11 AIRFLOW PERFORMANCE DATA (-)H1V – continued

Model Size (-)H1V	Nominal Cooling Capacity Tons	Motor Speed From Factory	Nominal Air-Flow CFM	Blower Size Motor H.P.	CFM Air Delivery/RPM/Watts-230 Volts (No Filter)										
					External Static Pressure-Inches W.C.										
						0.10	0.20	0.30	0.40	0.50	0.60	0.70	0.80	0.90	1.00
4824ST No heat	4.0	High	1600*	11x11 3/4	CFM	1607	1615	1622	1630	1637	1629	1621	1614	1606	1583
					RPM	612	698	747	788	835	870	914	950	981	1018
					Watts	225	297	334	359	410	439	469	502	532	568
4824ST with 25kw heat	4.0	High	1600*	11x11 3/4	CFM	1587	1589	1589	1591	1591	1577	1562	1549	1534	1505
					RPM	658	748	802	847	899	938	987	1027	1063	1104
					Watts	246	325	369	401	459	495	532	572	609	652
6024ST No heat	4.0 & 5.0	High	1600*	11x11 3/4	CFM	1607	1615	1622	1630	1637	1629	1621	1614	1606	1583
					RPM	612	698	747	788	835	870	914	950	981	1018
					Watts	225	297	334	359	410	439	469	502	532	568
6024ST with 25kw heat	4.0 & 5.0	High	1600*	11x11 3/4	CFM	1587	1589	1589	1591	1591	1577	1562	1549	1534	1505
					RPM	658	748	802	847	899	938	987	1027	1063	1104
					Watts	246	325	369	401	459	495	532	572	609	652
6024ST No heat	5.0	High	1800	11x11 3/4	CFM	1794	1808	1808	1808	1807	1807	1807	1800	1786	1772
					RPM	676	739	787	840	871	923	950	994	1028	1050
					Watts	330	376	416	465	504	554	576	624	662	694
6024ST with 30kw heat	5.0	High	1800	11x11 3/4	CFM	1756	1770	1770	1769	1769	1769	1769	1762	1748	1734
					RPM	713	778	828	884	917	971	1000	1047	1083	1107
					Watts	361	410	453	505	547	600	625	676	717	752

*To obtain the nominal airflow 600 CFM for 2417, 1000 CFM for 3617, 1400 CFM for 4821, and 1600 CFM for 4824/6024; the DIP switches 1 and 2 must be set for selection C or D. See Figure 25.

6.0 AIR HANDLER EQUIPPED WITH THE *COMFORT CONTROL² SYSTEMTM* INTERFACE BOARD (-)H2V

FIGURE 30
THE AIR HANDLER *COMFORT CONTROL² SYSTEMTM* CONTROL BOARD

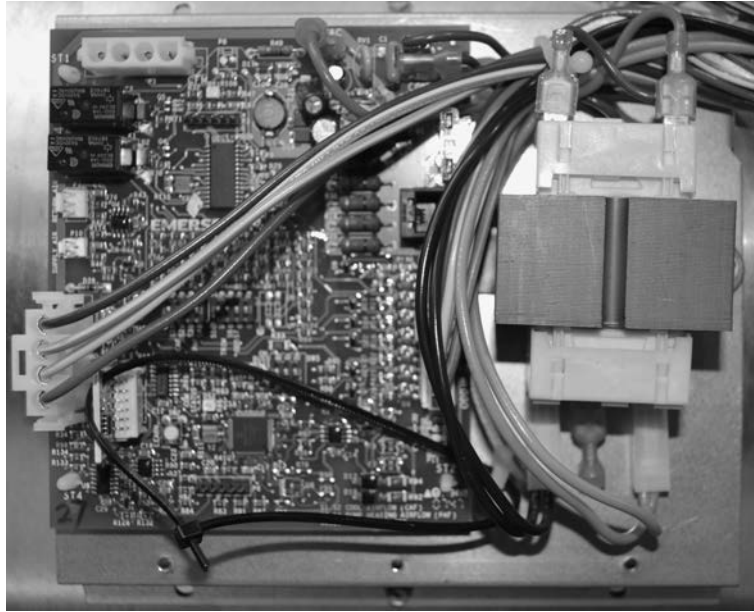

The (-)H2V series of air handlers are designed to operate with conventional 24VAC controls or with a serial communicating system.

For the *Comfort Control² SystemTM*, you must have:

- Air handler equipped with the *Comfort Control²*
- Condensing unit or heat pump equipped with the *Comfort Control² SystemTM*.
- A *Comfort Control²* thermostat

If your equipment does not meet this criteria, you must wire it using conventional 24VAC thermostat control wiring. Reference Section 4.8.

6.1 *COMFORT CONTROL² SYSTEMTM* CONTROL WIRING

Comfort Control² SystemTM requires four (4) control wires for unit operation:

- R – 24VAC
- C – 24VAC common
- 1 – Data wire 1
- 2 – Data wire 2

Wiring sizing for *Comfort Control²* is identical to systems using low voltage 24V wires.

Note: The *Comfort Control² SystemTM* requires a minimum 18 AWG.

IMPORTANT: When using the *Comfort Control²*, do not make any connections to the 24VAC thermostat wires. If any connections are made to the G, W1, W2, Y1, Y2, or ODD wires, the serial communicating control will assume the control is being used with a traditional thermostat and will IGNORE ANY COMMUNICATIONS USING DATA WIRE 1 AND DATA WIRE 2.

IMPORTANT: Class 2 low voltage control wire should not be run in conduit with power wiring and must be separated from power wiring, unless Class 1 wire of proper voltage rating is used.

- The four 18AWG low voltage control wires must be installed from the thermostat to the indoor unit and from indoor unit to the outdoor unit. The wire length between the thermostat and indoor unit should not be greater than 100 feet. The wire length between the indoor unit and outdoor unit should not be greater than 125 feet.
- Low voltage control connections are made by extending wires from top of air handler using wire nuts.
- See wiring diagrams attached to indoor and outdoor sections to be connected
- Do not leave excess field control wiring inside unit, pull excess control wire to outside of unit and provide strain relief for field wiring on inside of cabinet at point wiring penetrates cabinet.
- Make sure, after installation, separation of control wiring and power wiring has been maintained.

6.2 COMFORT CONTROL² SYSTEM™ CONTROL BOARD (-)H2V

FIGURE 31
TYPICAL COMFORT CONTROL² SYSTEM™ WIRING DIAGRAM

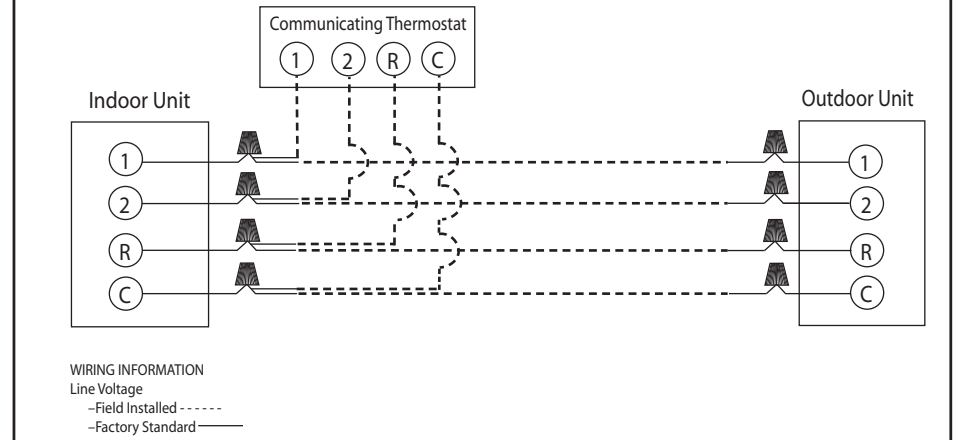

The (-)H2V series air handler control, Figure 30, has the following features:

- Memory Card – The memory card stores all information needed for unit operation. Once the system is wired for the *Comfort Control²*, this information is shared with the thermostat and outdoor unit. This *shared* data is available if one of the components in the system needs to be replaced.
- An automotive-style ATC blade fuse for transformer protection (3 amp).
- An on-board LED to indicate blower CFM.
- An RJ-11 port for use with a diagnostic tool.
- Inputs for field installed supply and return air temperature sensors (available in kit RXHT-A01)
- DIP switches for airflow adjustments

IMPORTANT: The DIP switches are NOT used when the air handler is wired for the *Comfort Control²*. Airflow adjustments are performed via the thermostat or a diagnostic tool.

Installation Verification

- Term and bias dip switches should be on.
- 24V AC power on R&C must be present at the control for the air handler to operate, reference Figure 31.
- Line voltage must be present at the control for indoor blower operation.
- The RX Data LED will flash green in normal operation. A flashing green light indicates 24VAC is present and the data wires 1 and 2 are wired properly.

IMPORTANT: If the RX DATA LED is solid green, data wire 1 and data wire 2 are not properly connected. Typically, the connections are switched, i.e. data wire 1 is wired to the data wire 2 connection and data wire 2 is wired to the data wire 1 connection. Verify wiring and correct the polarity at the two data wires.

IMPORTANT: Diagnostic port is not a phone jack. Connecting to a telephone or telephone system will result in damage.

IMPORTANT: Diagnostic port is for diagnostic tool only. Do not attempt to connect components using a telephone cord. Damage will occur.

6.3 USING THE ON-BOARD LED TO DETERMINE BLOWER CFM (-)H2V

The CFM LED indicates blower output by flashing one (1) flash for every 100 CFM of airflow. The LED will pause 1/10 second between each flash. (See Table 1.)

6.4 AIRFLOW ADJUSTMENTS WITH THE COMFORT CONTROL² SYSTEM™ (-)H2V

The RHPN air handler *Comfort Control² System™* may operate using the *Comfort Control²* or via traditional thermostat wiring. When the air handler is wired for the *Comfort Control²* using Data wire 1 and Data wire 2, the DIP switches on the *Comfort Control²* control have NO affect on the airflow.

IMPORTANT: When using the *Comfort Control²*, the DIP switches have no affect on airflow or on air handler performance.

6.5 COOLING AIRFLOW SETTINGS (BY TONNAGE) (-)H2V

The (-)H2V-series of air handlers automatically set cooling airflow when using the *Comfort Control*². The air handler detects the tonnage of the condensing unit/heat pump and sets airflow for optimum performance and comfort. Refer to Table 1 for the airflow provided when the (-)H2V air handler is matched to the RARL/RASL condensing units.

TABLE 7
RHPN AIRFLOW WHEN MATCHED TO THE (-)ASL CONDENSING UNITS (-)H2V

Condensing Unit Model	Airflow (cfm)	
	2nd Stage	1st Stage
(-)ASL-025	775	600
(-)ASL-037	1175	950
(-)ASL-039	1175	825
(-)ASL-048	1600	1000
(-)ASL-060	1700	1050

RHPN AIRFLOW WHEN MATCHED TO THE (-)ARL CONDENSING UNITS

Condensing Unit Model	Airflow (cfm)	
	2nd Stage	1st Stage
(-)ARL-025	775	600
(-)ARL-038	1175	950
(-)ARL-049	1600	1200
(-)ARL-061	1700	1275

6.6 COOLING AIRFLOW ADJUSTMENT (-)H2V

The *Comfort Control*² does allow the installer to tweak the cooling airflow +/-10% to suit the installation. When using the *Comfort Control*² SystemTM, the airflow can only be adjusted using the *Comfort Control*² thermostat or a service tool. To adjust the airflow, go to the airflow adjustment menu and select the desired adjustment. (Refer to Table 2).

TABLE 8
AIRFLOW ADJUSTMENT SELECTION TABLE (-)H2V

Selection
None
+10%
-10%

IMPORTANT: Cooling airflow adjustment is accessible via the *Comfort Control*² thermostat or via a service tool. Refer to their instructions to access the cooling airflow adjustment menu.

NOTE: Cooling airflow adjustments are in effect for cooling operation only. They are ignored when in heating mode or when electric heat is activated.

6.7 ELECTRIC HEAT AIRFLOW (-)H2V

The H2V-series of air handlers are factory programmed to provide adequate airflow for the maximum electric heat (auxiliary heat) allowed for a given model. Airflow adjustment for lower KW heater applications is accessible via the *Comfort Control*² System thermostat or via a service tool. Refer to their instructions to access the "Heating Airflow Adjustment" menu.

TABLE 9
ELECTRIC HEAT AIRFLOW FOR THE RHPN AIR HANDLERS (-)H2V

Air Handler Model	Above 15KW:	15KW and below:
RH2V2421HTACJA00	800 CFM	600 CFM
RH2V3624HTACJA00	1200 CFM	600 CFM
RH2V4824HTACJA00	1600 CFM	800 CFM
RH2V6024HTACJA00	1800 CFM	800 CFM

TABLE 10
ODD TERMINAL (-)H2V

INDOOR AMBIENT CONDITION	INPUT TO "ODD" TERMINAL (FROM HUMIDISTAT)
HIGH HUMIDITY	Ø VAC
LOW HUMIDITY	24 VAC

6.8 COOLING MODE DEHUMIDIFICATION (-)H2V

The *Comfort Control*² control is shipped with "On Demand Dehumidification" (ODD) turned OFF. On Demand Dehumidification may be activated when the serial communicating thermostat has an on-board humidity sensor.

IMPORTANT: On Demand Dehumidification is accessible via the *Comfort Control*² thermostat or via a service tool. Refer to their instructions to access the ODD airflow adjustment menu.

6.9 COOLING DELAY PROFILES (-)H2V

The (-)H2V air handler is factory configured with optimum ON/OFF delays to maximize energy efficiency and comfort. In certain situations, the installer may choose an alternate profile to tweak the system operation for the building load and to maximize comfort. The alternate profiles are defined below:

IMPORTANT: On Demand Dehumidification, ODD, is the preferred method to maximize comfort with little or no loss of energy efficiency. If using ODD, do NOT use any of the alternate profiles. Only use the factory default profile. Use of the alternate profiles with ODD will decrease energy efficiency with no gain in comfort.

Profile A – Factory default profile.

Air Handler	On Delay		Off Delay (seconds)
	Delay Duration (second)	% Rated Airflow	
RH2V2421HTACJA00	No delay	N/A	45
RH2V3624HTACJA00	No delay	N/A	45
RH2V4824HTACJA00	No delay	N/A	45
RH2V6024HTACJA00	No delay	N/A	45

Profile B – Quiet Start profile

The Quiet Start profile is configured to bring the blower up to 50% airflow for 30 seconds before advancing to 100% airflow. This minimizes air flow sounds at system startup.

Air Handler	On Delay		Off Delay (seconds)
	Delay Duration (second)	% Rated Airflow	
RH2V2421HTACJA00	30	50	15
RH2V3624HTACJA00	30	50	15
RH2V4824HTACJA00	30	50	15
RH2V6024HTACJA00	30	50	15

Profile C – Humid Climate Profile

The humid profile is configured to run the blower at 80% airflow for about the first four minutes of system operation to remove more moisture from the conditioned space.

Air Handler	On Delay		Off Delay (seconds)
	Delay Duration (second)	% Rated Airflow	
RH2V2421HTACJA00	255	80	0
RH2V3624HTACJA00	255	80	0
RH2V4824HTACJA00	255	80	0
RH2V6024HTACJA00	255	80	0

Profile D – Dry Climate profile

The Dry Climate profile is configured for areas that require little to no additional dehumidification.

Air Handler	On Delay		Off Delay (seconds)
	Delay Duration (second)	% Rated Airflow	
RH2V2421HTACJA00	150	88	60
RH2V3624HTACJA00	150	88	60
RH2V4824HTACJA00	150	88	60
RH2V6024HTACJA00	150	88	60

CONVENTIONAL THERMOSTAT WIRING

6.10 USING THE ON-BOARD LED TO DETERMINE BLOWER CFM (-)H2V

The (-)H2V interface board LED indicates blower output by flashing once for every 100 CFM of airflow. The LED will pause 1/10 second between each flash. (See Table 2.)

6.11 COOLING AIRFLOW SETTINGS

FIGURE 32
DIP SWITCH SETTING FOR COOLING AIRFLOW (-)H2V

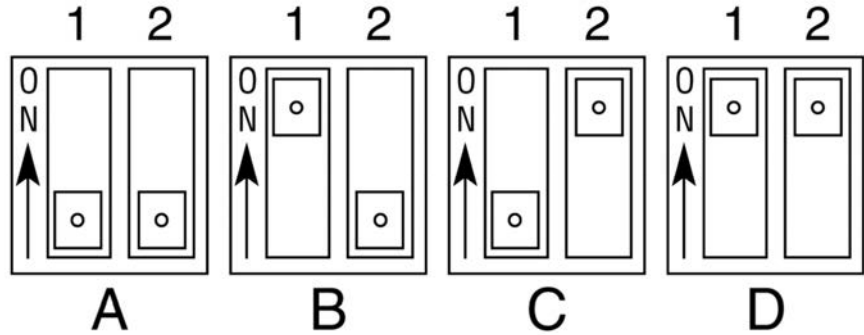

When not using the *Comfort Control² System™*, the (-)H2V air handler must be configured to deliver the proper airflow. Adjust DIP switches 1 and 2 per these tables for proper unit operation:

TABLE 11
AIRFLOW SETTINGS WHEN USING TRADITIONAL 24VAC THERMOSTAT (-)H2V

(-)H2V	Outdoor Unit (also see Section 5.13)*	Switch 1 Position	Switch 2 Position	Airflow (CFM)	
				2nd Stage (Y2)	1st Stage (Y1)
2421HT	(-)ASL-025	OFF	OFF	775	600
3624HT	(-)ASL-037	ON	OFF	1175	950
3624HT	(-)ASL-039	OFF	OFF	1175	825
4824HT	(-)ASL-048	OFF	OFF	1600	1000
6024HT	(-)ASL-060	OFF	OFF	1700	1050
2421HT	(-)ARL-025	ON	OFF	775	600
3624HT	(-)ARL-038	ON	OFF	1175	950
4824HT	(-)ARL-049	ON	OFF	1600	1200
6024HT	(-)ARL-061	ON	OFF	1700	1275

*6.12 COOLING AIRFLOW ADJUSTMENTS WITH SINGLE STAGE CONDENSING UNITS

The (-)H2V series of air handlers can be used with select single-stage condensing units. Refer to the Engineering Specifications Sheets to determine the required airflow for your particular combination. Refer to Table 5 to determine the air-flows available for each (-)H2V air handler. Reference Figures 27-30 for proper wiring of the system.

6.13 AIRFLOW ADJUSTMENT (-)H2V (TRIM)

FIGURE 33
DIP SWITCH SETTING FOR AIRFLOW ADJUSTMENTS

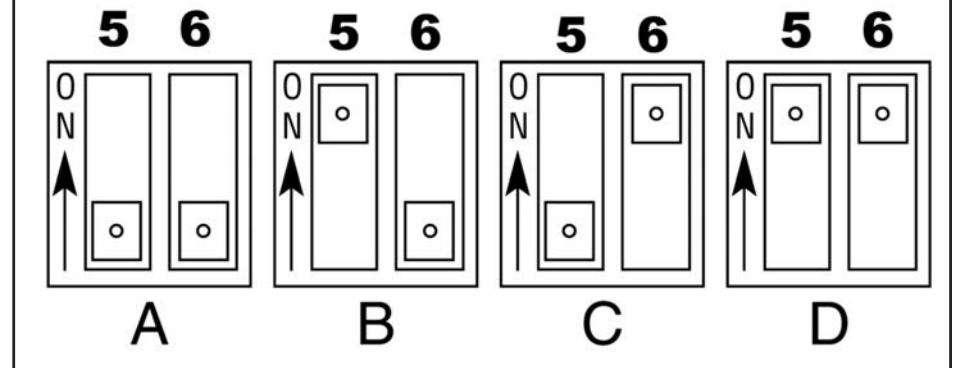

When not using the *Comfort Control² System™*, the (-)H2V air handler cooling airflow can be tweaked +/-10% to suit the installation. To adjust the airflow, adjust DIP switches 5 and 6 per this table:

IMPORTANT: The DIP switches are active only when using conventional a 24VAC thermostat. If using the *Comfort Control² System™*, refer to Section 5.4 for adjusting airflows.

NOTE: Airflow adjustment is active for cooling operation only. Cooling airflow adjustments are ignored when electric heat is activated.

6.14 ELECTRIC HEAT AIRFLOW

The RHPN-series air handlers are shipped with the “Low KW airflow” feature turned OFF. Activate lower airflow feature for lower KW electric heat applications by turning DIP switch 8 ON.

IMPORTANT: The DIP switches are active only when using a conventional 24VAC thermostat. If using the *Comfort Control² System™*, refer to section 5.5 for low KW heat airflow adjustment.

ELECTRIC HEAT AIRFLOW FOR THE RHPN AIR HANDLERS (-)H2V

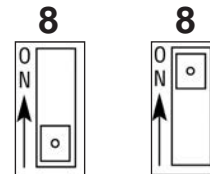

Air Handler Model	Above 15KW:	15KW and below:
RH2V2421HTACJA00	800 CFM	600 CFM
RH2V3624HTACJA00	1200 CFM	600 CFM
RH2V4824HTACJA00	1600 CFM	800 CFM
RH2V6024HTACJA00	1800 CFM	800 CFM

6.15 COOLING MODE DEHUMIDIFICATION

FIGURE 34
ON DEMAND DEHUMIDIFICATION DIP SWITCH (-)H2V



The (-)H2V series air handler is shipped with “On Demand Dehumidification” (ODD) turned OFF. On Demand Dehumidification is used in conjunction with a traditional 24VAC thermostat equipped with an on-board humidity sensor. Activate ODD by turning DIP switch 7 ON. ODD operation is controlled by the indoor humidity sensed at the thermostat. Operation is:

Normal Humidity (humidity BELOW the thermostat set point):

Normal Humidity	Result
A 24VAC signal is applied to the ODD terminal	Full rated airflow is delivered by the blower

High Humidity (humidity ABOVE the thermostat set point):

High Humidity	Result
No signal applied to the ODD terminal	Airflow is reduced by a preset amount to increase latent capacity

The (-)H2V air handler is programmed to provide maximum efficiency and optimum humidity removal. When high humidity is detected, the air handler reduces cooling airflow defined in Table 6.

TABLE 12
ODD AIRFLOW REDUCTION (-)H2V

(-)H2V	Outdoor Unit	Switch 1 Position	Switch 2 Position	Airflow (CFM)	
				2nd Stage (Y2)	1st Stage (Y1)
2421HT	(-)ASL-025	OFF	OFF	650	500
3624HT	(-)ASL-037	ON	OFF	950	750
3624HT	(-)ASL-039	OFF	OFF	950	650
4824HT	(-)ASL-048	OFF	OFF	1275	800
6024HT	(-)ASL-060	OFF	OFF	1350	850
2421HT	(-)ARL-025	ON	OFF	650	500
3624HT	(-)ARL-038	ON	OFF	950	750
4824HT	(-)ARL-049	ON	OFF	1275	950
6024HT	(-)ARL-061	ON	OFF	1350	1025

IMPORTANT: The DIP switches are active only when using conventional a 24VAC thermostat. If using the *Comfort Control² System™*, refer to Section 5.4 for adjusting airflows.

NOTE: ODD airflow adjustments are active for cooling operation only. They are ignored when the heat pump is in heating mode or when electric heat is activated.

6.16 COOLING DELAY PROFILES (-)H2V

Cooling delay profiles are not available when the H2V air handler is controlled using a conventional 24VAC thermostat. These profiles are available only when the air handler is wired for the *Comfort Control² System™*. Refer to Section 5.4 for the *Comfort Control² Cooling Delay Profiles*.

6.17 AIRFLOW PERFORMANCE DATA (-)H2V

Air Handler (-)H2V	Outdoor Unit	Cabinet Size	Blower		Nominal Airflow CFM	CFM RPM WATTS	External Static Pressure - In. W.C.										
			Size Motor HP	Unit Operation			230 Volts										
							0.1	0.2	0.3	0.4	0.5	0.6	0.7	0.8	0.9	1.0	
2421HT	(-)ARL-025 or (-)ASL-025	21	10x8 1/3	First Stage (Y1)	600	550	575	600	600	625	625	625	600	575	550		
				Second Stage (Y2)	775	455	540	620	695	760	825	885	940	985	1030		
							40	55	70	85	105	120	135	150	170	185	
							775	775	775	800	800	825	825	825	825	825	825
							540	615	685	750	810	870	925	975	1020	1065	
							70	90	115	135	160	180	205	225	250	270	
3624HT	(-)ARL-038 or (-)ASL-037	24	11x11 3/4	First Stage (Y1)	950	950	950	1000	975	975	975	925	925	925	925		
				Second Stage (Y2)	1175	495	555	610	665	720	770	820	865	910	955		
							95	115	140	165	185	210	240	265	290	320	
							1175	1150	1150	1175	1175	1175	1150	1150	1150	1125	1125
							550	600	650	700	750	800	850	900	925	975	
							125	175	200	225	250	275	300	325	375	400	
		(-)ASL-039					825	825	875	875	850	850	825	825	800	800	
							455	515	575	630	680	730	780	830	875	915	
							70	90	115	135	155	180	205	230	255	280	
							1175	1150	1175	1175	1175	1150	1150	1150	1125	1125	
							550	600	650	700	750	800	850	900	925	975	
							125	175	200	225	250	275	300	325	375	400	
4824HT	(-)ARL-049	24	11x11 3/4	First Stage (Y1)	1200	1275	1275	1250	1250	1275	1250	1250	1225	1225	1225		
				Second Stage (Y2)	1600	533	593	649	702	752	798	841	881	917	950		
							131	161	191	221	250	279	307	335	363	390	
							1650	1650	1675	1700	1700	1700	1675	1675	1675	1675	1675
							635	698	761	824	887	950	1013	1075	1120	1006	
							244	293	340	384	425	464	500	533	564	592	
		(-)ASL-048					1000	1000	1025	1025	1000	1000	975	975	975	975	
							500	575	625	675	725	775	825	875	925	950	
							100	125	150	175	200	225	250	275	300	325	
							1650	1650	1675	1700	1700	1700	1675	1675	1675	1675	
							635	698	761	824	887	950	1013	1075	1120	1006	
							244	293	340	384	425	464	500	533	564	592	
6024HT	(-)ARL-061	24	11x11 3/4	First Stage (Y1)	1275	1275	1275	1275	1275	1275	1275	1275	1250	1250	1250		
				Second Stage (Y2)	1700	577	633	687	738	786	831	874	914	951	986		
							159	189	218	248	279	310	341	372	404	436	
							1625	1625	1650	1675	1675	1650	1650	1625	1625	1625	
							691	742	790	835	877	916	953	986	1016	1044	
							289	334	377	417	456	493	529	562	593	623	
		(-)ASL-060					1050	1050	1075	1075	1050	1025	1025	1025	1025	1000	
							525	575	625	675	750	800	825	875	925	975	
							100	125	150	175	225	250	275	300	325	350	
							1625	1625	1650	1675	1675	1650	1650	1625	1625	1625	
							691	742	790	835	877	916	953	986	1016	1044	
							289	334	377	417	456	493	529	562	593	623	

IMPORTANT: Observe airflow operating limits. Do not operate above 1.0 in. W.C. system external static.

CONVENTIONAL THERMOSTAT WIRING

6.18 AIR HANDLER DIAGNOSTIC CODES (-)H2V

Descriptions of the air handler *Comfort Control*[®] diagnostic codes are provided below. These codes can be displayed at the thermostat or via a diagnostic tool.

IMPORTANT: Air handler diagnostic codes are available at the thermostat when the system is wired for the *Comfort Control*[®]. If using the *Comfort Control*[®], refer to the following diagnostic codes.

6.18 AIR HANDLER DIAGNOSTIC CODES (-)H2V (continued)

Descriptions of the ICC diagnostic codes are provided below:

7-Segment LEDs Display Code	Diagnostic Description	Status/Possible Cause – Troubleshooting Information
d1	d1 – No Shared Data The control board does not have shared data.	<ul style="list-style-type: none"> • Replace memory card with correct system information
d3	d3 – Airflow CFM Mismatch The air handler cannot supply the required airflow for proper system operation	<ul style="list-style-type: none"> • Misapplied/wrong indoor air mover – replace with properly sized air handler/furnace.
d4	d4 – (Device) Memory Card Invalid for Device The memory card is missing or the data in the memory card does not match the data in the control.	<ul style="list-style-type: none"> • Check memory card to ensure it matches device • Check if memory card is present
d5	d5 – Card Hardware Conflict The motor horsepower is not correct for the air handler	<ul style="list-style-type: none"> • Replace the air handler motor with the correct horsepower motor. • Replace the memory card with correct system information.
d6	d6 – BLWR HP CNFLCT Blower Horsepower conflict The horsepower data in the memory card does not match the motor horsepower.	<ul style="list-style-type: none"> • Replace the motor with correct horsepower motor. • Replace the memory card with correct system information. Check memory card to ensure it matches device
d7	d7 – BLWER MFG CNFLCT The System does not have any data on the installed motor.	<ul style="list-style-type: none"> • Replace the memory card with correct system information.
d8	d8 – Old Shared Data System data is obsolete	<ul style="list-style-type: none"> • If system will not operate, order new memory card to update system information.
60	60 – BLWR FLT–RUN The ECM motor is running but has a fault	<ul style="list-style-type: none"> • TEST the ECM for proper operation.
61	61 – BLWR FLT–NO RUN The ECM motor is not operating	<ul style="list-style-type: none"> • Make sure the ECM motor wiring harness is plugged into the ECM motor and control board. • Test the ECM motor for proper operation.
68	68 – ECM No Signal The ECM motor is not communicating to the air handler control board.	<ul style="list-style-type: none"> • Make sure the ECM motor wiring harness is plugged into the ECM motor and control board. • Test the ECM motor for proper operation using a service tool.
81	81 – Return Air Sensor Out of Range The resistance of the sensor out of range for normal operation.	<ul style="list-style-type: none"> • Make sure the sensor is plugged into the air handler control board. • Check the resistance of the sensor. Replace if it is out of tolerance.
82	82 – Supply Air Sensor Out of Range The resistance of the sensor out of range for normal operation.	<ul style="list-style-type: none"> • Make sure the sensor is plugged into the air handler control board. • Check the resistance of the sensor. Replace if it is out of tolerance.
93	93 – Internal Control Fault The air handler control is not functioning.	<ul style="list-style-type: none"> • Check control for proper system operation. • Replace control

7.0 DUCTWORK

Field ductwork must comply with the National Fire Protection Association NFPA 90A, NFPA 90B and any applicable local ordinance.

WARNING

Do not, under any circumstances, connect return ductwork to any other heat producing device such as fireplace insert, stove, etc. Unauthorized use of such devices may result in fire, carbon monoxide poisoning, explosion, personal injury or property damage.

Sheet metal ductwork run in unconditioned spaces must be insulated and covered with a vapor barrier. Fibrous ductwork may be used if constructed and installed in accordance with SMACNA Construction Standard on Fibrous Glass Ducts. Ductwork must comply with National Fire Protection Association as tested by U/L Standard 181 for Class I Air Ducts. **Check local codes for requirements on ductwork and insulation.**

- Duct system must be designed within the range of external static pressure the unit is designed to operate against. It is important that the system airflow be adequate. Make sure supply and return ductwork, grills, special filters, accessories, etc. are accounted for in total resistance. See airflow performance tables in this manual.
- Design the duct system in accordance with “ACCA” Manual “D” Design for Residential Winter and Summer Air Conditioning and Equipment Selection. Latest editions are available from: “ACCA” Air Conditioning Contractors of America, 1513 16th Street, N.W., Washington, D.C. 20036. If duct system incorporates **flexible air duct**, be sure **pressure drop** information (straight length plus all turns) shown in “ACCA” Manual “D” is accounted for in system.
- Supply plenum is attached to the 3/4” duct flanges supplied on the unit around the blower outlet. Flanges are flat for shipping purposes and must be bent up along perforated edge around blower opening. Be sure to bend flanges completely up so they do not interfere with air being discharged from blower.

IMPORTANT: Flanges around blower opening for attaching supply duct must be up out of blower discharge even if not used so they do not restrict airflow from blower.

IMPORTANT: If an elbow is included in the plenum close to the unit, it must not be smaller than the dimensions of the supply duct flange on the unit.

- Some units with electric heaters require 1 in. clearance to supply plenum and branch ducts to combustible material for the first 3 feet from the unit. See CLEARANCES.
- A 3/4” return duct flange is supplied on all sides of the air inlet opening of the unit coil casing. If the unit is to be installed without a coil casing (no indoor coil), a 3/4” flange is supplied on the back and sides of the air inlet opening of the blower casing. No flange is provided on the front of the opening to the blower casing. If return duct is attached to the inlet of the blower casing, the front flange of the duct should be run up into the opening or 90° brake made on the front flange to tape to the front of the blower casing.
- **IMPORTANT:** The front flange on the return duct if connected to the blower casing must not be screwed into the area where the power wiring is located. Drills or sharp screw points can damage insulation on wires located inside unit.
- Return duct flanges on blower or coil casing are flat for shipping purposes and must be bent out along perforated edge around opening.
- Secure the supply and return ductwork to the unit flanges, using proper fasteners for the type of duct used and tape the duct-to-unit joint as required to prevent air leaks.

8.0 REFRIGERANT CONNECTIONS

Keep the coil connections sealed until refrigerant connections are to be made. See the Installation Instructions for the outdoor unit for details on line sizing, tubing installation, and charging information.

Coil is shipped with a low (5 - 10 PSIG) pressure charge of dry nitrogen. Evacuate the system before charging with refrigerant.

Install refrigerant tubing so that it does not block service access to the front of the unit.

Nitrogen should flow through the refrigerant lines while brazing.

Make sure to protect TXV, copper to aluminum joint, and service valves from overheating by use of wet rag or some type of shielding. Double tip torches are not recommended.

Use a brazing shield to protect the cabinet's paint from being damaged by torch flames.

After the refrigerant connections are made, seal the gap around the connections with pressure sensitive gasket. If necessary, cut the gasket into two pieces for a better seal.

8.1 TEV SENSING BULB

IMPORTANT: DO NOT perform any soldering with the TEV bulb attached to any line.

After soldering operations have been completed, clamp the TEV bulb securely on the suction line at the 10 to 2 o'clock position with the strap provided in the parts bag.

Insulate the TEV sensing bulb and suction line with the provided pressure sensitive insulation (size 4" x 7") and secure with provided wire ties.

IMPORTANT: TEV sensing bulb should be located on a horizontal section of suction line, just outside of coil box. The copper sensing bulb must never be placed on any aluminum tube as this will result in galvanic corrosion and eventual failure of the aluminum tube.

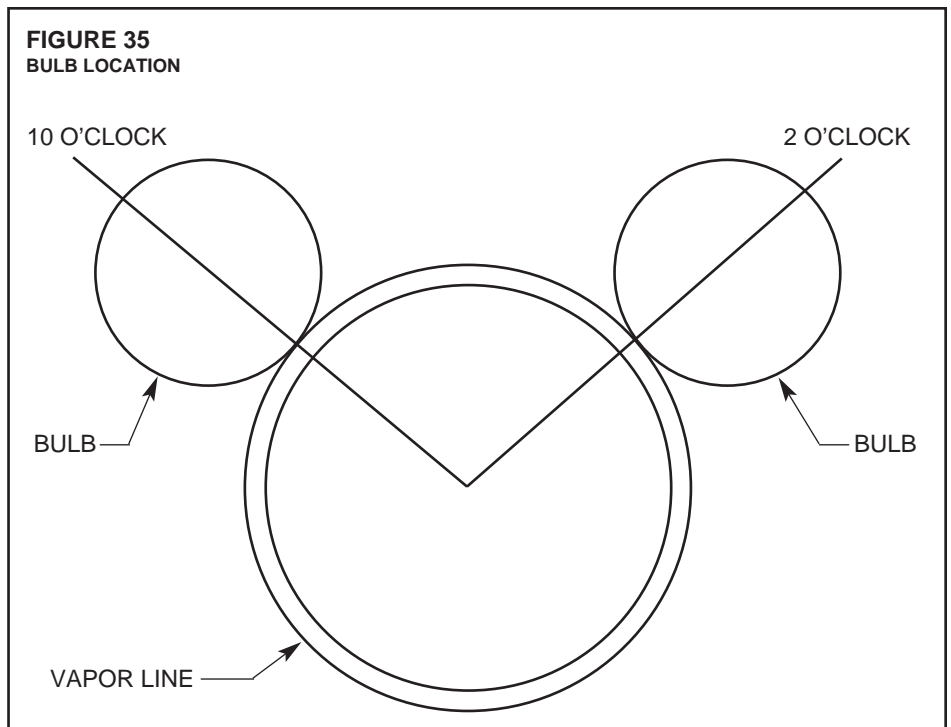
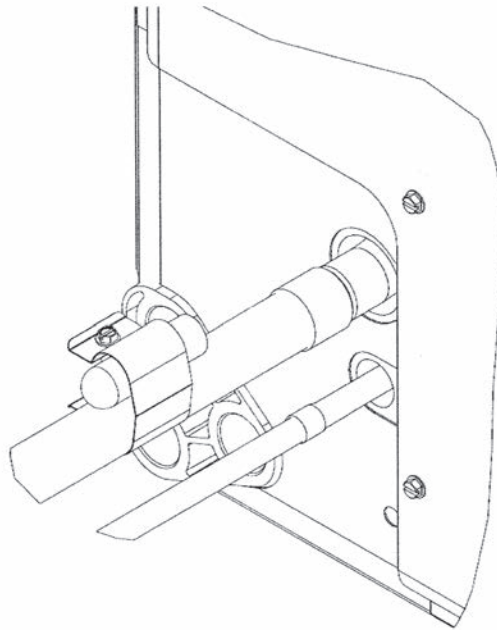

FIGURE 36
BULB LOCATION



8.2 CONDENSATE DRAIN TUBING

Consult local codes or ordinances for specific requirements.

IMPORTANT: When making drain fitting connections to the drain pan, use a thin layer of Teflon paste, silicone or Teflon tape and install hand tight.

IMPORTANT: When making drain fitting connections to drain pan, do not overtighten. Overtightening fittings can split pipe connections on the drain pan.

- Install drain lines so they do not block service access to front of the unit. Minimum clearance of 24 inches is required for filter, coil or blower removal and service access.
- Make sure unit is level or pitched slightly toward primary drain connection so that water will drain completely from the pan. (See Figure 20.)
- Do not reduce drain line size less than connection size provided on condensate drain pan.
- All drain lines must be pitched downward away from the unit a minimum of 1/8" per foot of line to ensure proper drainage.
- Do not connect condensate drain line to a closed or open sewer pipe. Run condensate to an open drain or outdoors.
- The drain line should be insulated where necessary to prevent sweating and damage due to condensate forming on the outside surface of the line.
- Make provisions for disconnecting and cleaning of the primary drain line should it become necessary. Install a 3 in. trap in the primary drain line as close to the unit as possible. Make sure that the top of the trap is below connection to the drain pan to allow complete drainage of pan (See Figure 37).
- Auxiliary drain line should be run to a place where it will be noticeable if it becomes operational. Occupant should be warned that a problem exists if water should begin running from the auxiliary drain line.
- Plug the unused drain connection with the plugs provided in the parts bag, using a thin layer of teflon paste, silicone or teflon tape to form a water tight seal.
- Test condensate drain pan and drain line after installation is complete. Pour water into drain pan, enough to fill drain trap and line. Check to make sure drain pan is draining completely, no leaks are found in drain line fittings, and water is draining from the termination of the primary drain line.

8.3 DUCT FLANGES

Field-installed duct flanges (4 pieces) are shipped with units. Install duct flanges as needed on top of the unit. (See Figure 3.)

FIGURE 37
CONDENSATE DRAIN TRAP

**DO NOT OPERATE UNIT WITHOUT
CONDENSATE DRAIN TRAP.**

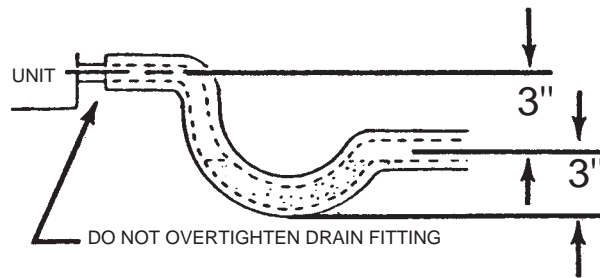

**UNIT MUST BE SLIGHTLY INCLINED
TOWARD DRAIN CONNECTION.**

9.0 AIR FILTER (Not Factory-Installed)

If a remote filter is installed, it should be sized for a maximum of 300 feet/min. air velocity for the CFM required.

IMPORTANT: Do not operate system without a filter. A filter is required to protect the coil, blower and internal parts from excessive dirt and dust.

10.0 SEQUENCE OF OPERATION

10.1 Cooling (cooling only or heat pump)

- When the thermostat “calls for cooling,” the circuit between R, G and Y is completed, causing the blower to energize. This circuit also closes the contactor (CC) in the outdoor unit starting the compressor (COMP) and outdoor fan motor (OFM).

10.2 Heating (electric heat only)

- When the thermostat “calls for heat,” the circuit between R and W₁ is completed, and the heater sequencer (HR₁) is energized. A time delay will follow then: The heating elements (HE) and the indoor blower motor (IBM) will come on. Units with a second heater sequencer (HR₂) can be connected with the first sequencer (HR₁) to W on the thermostat sub-base or connected to a second stage W₂ on the sub-base. W₁ on the furnace board **MUST** be connected for heating blower operation.

10.3 Heating (heat pump)

- When the thermostat “calls for heat,” the circuits between R and G are completed. Circuit R and B energizes the reversing valve (RV) switching it to the heating position (remains energized as long as system switch is in “heat” position). Circuit R and Y energizes the contactor (CC) starting the outdoor fan motor (OFM), compressor (COMP), and the indoor blower motor (IBM).
- If the room temperature should continue to fall, circuit R and W₂ is completed by the second-stage heat room thermostat. Circuit R-W₂ energizes a heat sequencer (HR₂). The completed circuit will energize supplemental electric heat. Units with a second heater sequencer (HR₂) can be connected with first sequencer (HR₁) to W₂ on thermostat or connected to a third heating stage W₃ on the thermostat sub-base. A light on the thermostat indicates when supplemental heat is being energized.

10.4 DEFROST

- For sequence of operation for defrost controls, see outdoor heat pump installation instructions.
- Supplemental heat during defrost can be provided by connecting the purple (PU) pig-tail in the outdoor unit to P on the indoor unit control board. This will complete the circuit between R and W through a set of contacts in the defrost relay (DR) when the outdoor heat pump is in defrost. This circuit, if connected, will temper air being discharged from the indoor unit during defrost.

- Defrost heat control (DHC) is wired in series in the circuit described above on units where the supplemental heat is more than would be required to offset the defrost cooling capacity. Defrost heat control (DHC) is provided on the same models described above having watt restrictors.
- When the outdoor unit goes into defrost, the circuit between R and W is completed through a set of contacts on the defrost relay (DR) in series with the contacts on the defrost heat control (DHC). Purple (PU) pigtailed on the indoor unit and outdoor units must be connected to make circuit. During defrost, the defrost heat control (DHC) senses the air temperature leaving the indoor unit and cycles the supplemental electric heat to maintain comfort (75° to 85°) air temperature and prevent objectionable cold air during defrost. This limits the electric heat output to the minimum required, to conserve energy and prevent the thermostat from being satisfied with electric heat and preventing completion of the defrost cycle.
- For most economical operation, if cold air is not of concern during defrost, the purple wire can be left disconnected. Supplemental heat will only be energized by a call from second stage room thermostat.

10.5 EMERGENCY HEAT (Heating of Heat Pump)

- If selector switch on thermostat is set to the emergency heat position, the heat pump will be locked out of the heating circuit, and all heating will be electric heat. Jumper should be placed between W₂ and E on the thermostat sub-base so that the electric heat control will transfer to the first stage heat on the thermostat. This will allow the indoor blower to cycle on and off with the electric heat when the fan switch is in the auto position.

10.6 ROOM THERMOSTAT (ANTICIPATOR SETTING)

See instructions with outdoor section, condensing unit or heat pump for recommended room thermostats.

- On units with one electric heat sequencer (HR₁) (see wiring diagram on unit), heat anticipator setting should be .16.
- On units with two electric heat sequencers (HR₁ & HR₂) (see wiring diagram on unit), heat anticipator setting should be .32 if both are connected to same stage on thermostat. Setting should be .16 if (HR₁ & HR₂) are connected to separate stages.

NOTE: Some thermostats contain a fixed, non-adjustable heat anticipator. Adjustment is not permitted.

- The thermostat should be mounted 4 to 5 feet above the floor on an inside wall of the living room or a hallway that has good air circulation from the other rooms being controlled by the thermostat. It is essential that there be free air circulation at the location of the same average temperature as other rooms being controlled. Movement of air should not be obstructed by furniture, doors, draperies, etc. The thermostat should not be mounted where it will be affected by drafts, hot or cold water pipes or air ducts in walls, radiant heat from fireplace, lamps, the sun, T.V. or an outside wall. See instruction sheet packaged with thermostat for mounting and installation instructions.

NOTE: Some thermostats, particularly solid-state digital types, contain fixed, non-adjustable heat anticipators and adjustment is not permitted.

11.0 CALCULATIONS

11.1 CALCULATING TEMPERATURE RISE

- The formula for calculating air temperature rise for electric resistance heat is:

$$\text{Temperature Rise } ^\circ\text{F} = \frac{3.16 \times \text{Watts}}{\text{CFM}}$$

Where: 3.16 = Constant, CFM = Airflow

11.2 CALCULATING BTUH HEATING CAPACITY

- The formula for calculating BTUH heating capacity for electric resistance heat is:

$$\text{BTUH Heating} = \text{Watts} \times 3.412$$

Where: 1 kW = 1000 Watts, 3.412 = Btuh/Watt

11.3 CALCULATING AIRFLOW CFM

- The formula for calculating airflow using temperature rise and heating BTUH for units with electric resistance heat is:

$$\text{CFM} = \frac{\text{Heating BTUH}}{1.08 \times \text{Temp. Rise}}$$

11.4 CALCULATING CORRECTION FACTOR

- For correction of electric heat output (kW or BTUH) or temperature rise at voltages other than rated voltage multiply by the following correction factor:

$$\text{Correction Factor} = \frac{\text{Applied Voltage}^2}{\text{Rated Voltage}^2}$$

12.0 PRE-START CHECKLIST

PRE-START CHECKLIST	
<input type="radio"/> YES <input type="radio"/> NO	Is unit properly located, level, secure and service-able?
<input type="radio"/> YES <input type="radio"/> NO	Has auxiliary pan been provided under the unit with separate drain? (Units installed above a finished ceiling).
<input type="radio"/> YES <input type="radio"/> NO	Is condensate line properly sized, run, trapped, pitched and tested?
<input type="radio"/> YES <input type="radio"/> NO	Is ductwork correctly sized, run, taped and insulated?
<input type="radio"/> YES <input type="radio"/> NO	Have all cabinet openings and wiring been sealed with caulking?
<input type="radio"/> YES <input type="radio"/> NO	Is the filter clean, in place and of adequate size?
<input type="radio"/> YES <input type="radio"/> NO	Is the wiring tight, correct and to the wiring diagram?
<input type="radio"/> YES <input type="radio"/> NO	Is the unit properly grounded and protected (fused)?
<input type="radio"/> YES <input type="radio"/> NO	Is the thermostat heat anticipator been set properly?
<input type="radio"/> YES <input type="radio"/> NO	Is the unit circuit breaker(s) rotated properly "on" up - "off" down?
<input type="radio"/> YES <input type="radio"/> NO	Are the unit circuit breaker(s) line lug cover(s) in place?
<input type="radio"/> YES <input type="radio"/> NO	Are all access panels in place and secure?
Refer to outdoor unit installation instructions for system start-up instructions and refrigerant charging instructions.	

13.0 MAINTENANCE

For continuing high performance, and to minimize possible equipment failure, it is essential that periodic maintenance be performed on this equipment. Consult your local dealer as to the proper frequency of maintenance and the availability of a maintenance contract.

IMPORTANT: Before performing any service or maintenance procedures, read all "WARNINGS" listed in these installation instructions.

⚠ WARNING

Units with circuit breaker(s) meet requirements as a service disconnect switch, however, if access is required to the line side (covered) of the circuit breaker, this side of the breaker(s) will be energized with the breaker(s) de-energized. Contact with the line side can cause electrical shock resulting in personal injury or death.

13.1 AIR FILTER (Not Factory Installed)

Check the system filter every ninety days or as often as found to be necessary and if obstructed, clean or replace at once.

IMPORTANT: Do not operate the system without a filter in place.

13.2 INDOOR COIL - DRAIN PAN - DRAIN LINE

Inspect the indoor coil once each year for cleanliness and clean as necessary. It is necessary to remove the filter and check the return air side of the coil for debris.

IMPORTANT: Do not use caustic household drain cleaners, such as bleach, in the condensate pan or near the indoor coil. Drain cleaners will quickly damage the indoor coil.

CAUTION

In compliance with recognized codes, it is recommended that an auxiliary drain pan be installed under all evaporator coils or units containing evaporator coils that are located in any area of a structure where damage to the building or building contents may occur as a result of an overflow of the coil drain pan or a stoppage in the primary condensate drain piping. See accessory section in this manual for secondary horizontal drain pan RXBM-ABXX.

13.3 THE COMFORT CONTROL² SYSTEM™ CONTROL BOARD REPLACEMENT

Verification of the *Comfort Control² System™* control board failure is required before replacement. Access the diagnostic codes using a service tool or access the installer menus using the thermostat (the system must be wired as a serial communicating system to access the installer menus using the thermostat). Reference the Air Handler Diagnostic Code Table in Section 5.20.

NOTE: The memory card is attached to the control box with a tether. The tether has an identification label that can be used to identify the memory card if replacement is needed.

IMPORTANT: Do not cut the tether attached to the memory card when replacing the *Comfort Control²*. Reinsert the memory card into the replacement *Comfort Control²*.

FIGURE 38
COMFORT CONTROL² BOARD REPLACEMENT

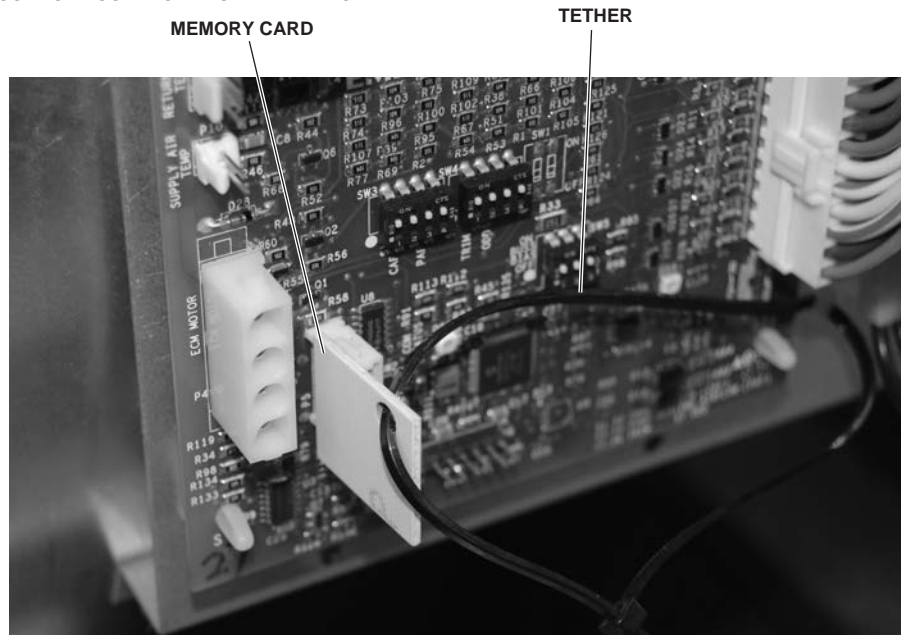

13.4 BLOWER MOTOR AND WHEEL

Inspect the blower motor and wheel for cleanliness. With the system air filter in place, it should be several years before it would become necessary to clean the blower motor and wheel.

- If it becomes necessary to remove the blower assembly from the unit, see instructions on removal and disassembly of motor, blower and heater parts.
- The blower motor and wheel may be cleaned by using a vacuum with a soft brush attachment. Remove grease with a mild solvent such as hot water and detergent. Be careful not to disturb the balance weights (clips) on the blower wheel blades. Do not drop or bend wheel as balance will be affected.

13.5 LUBRICATION

The blower motor sleeve bearings are pre-lubricated by the motor manufacturer and do not have oiling ports. Motor should be run for an indefinite period of time without additional lubrication.

13.6 BLOWER ASSEMBLY REMOVAL AND REPLACEMENT

Removing the blower assembly is not required for normal service and maintenance. Removal is necessary for replacement of components such as motor, blower wheel. After extended use, removal of the blower assembly may become necessary for a thorough cleaning of the blower motor and wheel.

WARNING

If removal of the blower assembly is required, all disconnect switches supplying power to the airhandler must be de-energized and locked (if not in sight of unit) so the field power wires can be safely removed from the blower assembly. Failure to do so can cause electrical shock resulting in personal injury or death.

- Mark field power supply wiring (for replacement) attached to terminal block or circuit breaker(s) on blower assembly. Remove wiring from terminal block or circuit breaker(s).
- Mark low voltage control wiring (for replacement) where attached to unit control terminals on left side of blower housing.
- Remove a screw holding blower assembly to front channel of cabinet and pull blower assembly from cabinet.
- To replace blower assembly, slide blower assembly into blower deck. Make sure blower assembly engages lances in deck properly. If assembly hangs up, check to make sure top and bottom are lined up in proper locations.
- Slide blower assembly to back of cabinet and make sure it is completely engaged.
- Replace two screws holding blower assembly to front channel of cabinet. Take care not to strip screws, just snug into place.
- Replace low voltage control wiring with wire nuts and make sure wiring is to wiring diagram and a good connection has been made.
- Replace field power wiring to terminal block or circuit breaker(s) on control area of blower assembly. Make sure wires are replaced as they were, check wiring diagram if necessary. Tighten supply power wiring securely to terminals lugs.
- Make sure wiring is within cabinet and will not interfere with access door. Make sure proper separation between low voltage control wiring and field power wiring has been maintained.
- Replace blower assembly control access panel before energizing equipment.

13.7 MOTOR REPLACEMENT

With the blower assembly removed, the indoor blower motor can be removed and replaced using the following procedure:

- Remove motor leads from the motor high and low voltage plugs. Note the lead locations for ease of re-assembly.
- Loosen the set screw holding the blower wheel onto the motor shaft. The shaft extends through the blower hub so that a wrench can be used on the extended shaft to break the shaft loose if necessary. Be careful not to damage the shaft. Use a wheel puller on the groove in the hub if necessary.

FIGURE 39
INTERNAL MOTOR PLUG AND SOCKET

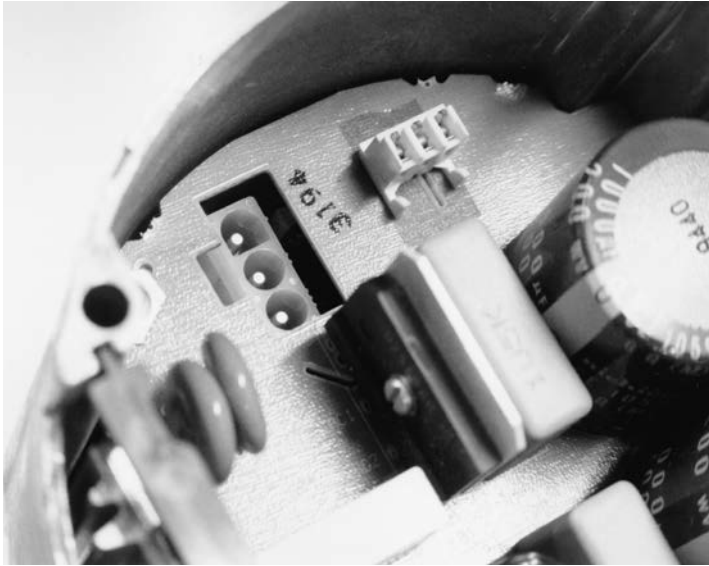

- Loosen the bolt holding the wire motor band around the motor shell and pull the motor from the motor mount. Note the motor position in the mount for re-assembly.
- To re-assemble, insert the motor shaft through the hub in the blower wheel and orient the motor to original position.
- For proper motor cooling, it is important that the motor be mounted the same as the original, as far into the blower as practical.
- The dimension from the face of the motor end plate (shaft end) to the first wire on the motor mount band around the shell should be:

DIMENSION	TONNAGE	CABINET SIZE
1 ³ / ₃₂ "	1 ¹ / ₂ & 2	17
1 ¹ / ₂ "	2 ¹ / ₂ & 3	17
2 ¹ / ₂ "	3, 3 ¹ / ₂ & 4	21
2 ⁷ / ₈ "	5	24

- With motor held to above position and motor lead plugs oriented to the original position (the wire connectors on the motor must point straight to the supply air end of the unit and away from the return air [filter] end of the unit). Securely tighten the bolt on the mount band to the motor shell.
- Turn the motor shaft so that the flat on the shaft is located under blower wheel setscrew, and the blower wheel is centered in the blower housing with the same distance on each side between the inlet venturi and the outside of the blower wheel.
- Re-assemble the motor wiring (high and low voltage plugs) into the motor.

IMPORTANT: DO NOT FORCE POWER PLUG INTO THE MOTOR CONNECTOR BACKWARDS. The A.C. power plug to the motor has locking tabs. It has been proven that by applying excessive force to the A.C. cable half of the connector it is possible to force the connector in backwards. It will not seat and "click" properly but will make connection. If A.C. power is applied with the connector reversed the motor will be immediately destroyed.

13.8 ECM CONTROL MODULE REPLACEMENT

Always take the following steps before replacing the control module on the end of the ECM indoor blower motor.

1. **HAVE THE CORRECT REPLACEMENT MODULE.** These controls are factory programmed for specific operating modes. Even though they look alike, different modules may have different CFM characteristics.

IMPORTANT: Using the wrong control module voids all product warranties and may produce unexpected results.

2. Turn off power to the equipment. Wait at least 5 minutes after disconnecting AC power before opening the motor.

WARNING

Always have 240 volt power turned off to the furnace before attempting any replacement of the motor or control module. Failure to do so may result in serious equipment damage, personal injury or death.

3. While not necessary, it may prove easier to remove the complete blower assembly from the furnace. Unplug the two cable connectors to the motor. There are latches on each connector. DO NOT PULL ON THE WIRES. TO REMOVE THE PLUG, SQUEEZE THE PIN LATCH. The plugs remove easily when properly released.

FIGURE 40
ECM MOTOR COMPONENTS

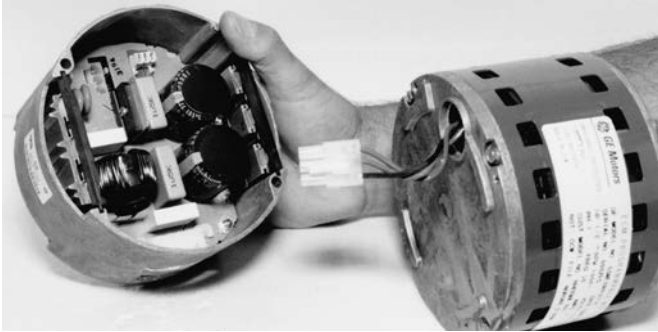
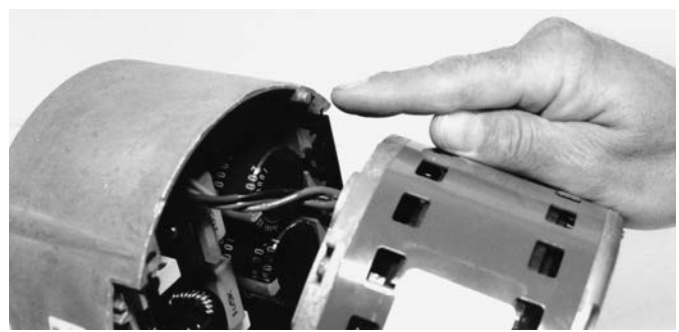

FIGURE 41
MOTOR ALIGNMENT PIN



4. Locate the two standard 1/4" hex head bolts on the flat end of the motor control module casting. Remove these bolts from the motor while holding the control module. DO NOT REMOVE TWO SCREWS WITH TORX HEADS.
5. The control module is still connected to the motor by a plug and cable. Carefully rotate the control so as to gain access to the plug on the cable end. Squeeze the release latch and gently pull the plug out of the control module. DO NOT PULL ON THE WIRES. GRIP THE PLUG ONLY.
6. The control module is now completely detached from the motor. Use an ohmmeter to measure the resistance from each motor lead (in the motor plug just removed) to the motor shell. This resistance must be greater than 100K ohms. Always measure to the unpainted motor end plate. If any motor lead fails this test DO NOT INSTALL THE NEW CONTROL MODULE.
7. Verify that the replacement control module is correct. Place the new module next to the motor and carefully insert the plug that was removed in step 5. BE SURE THE PLUG LATCHES. IT SHOULD CLICK INTO PLACE.
8. Install the new control module back on the motor. Carefully engage the alignment pin into the appropriate mating motor hole.
9. Replace the two 1/4" hex head bolts. Tighten the bolts snugly. DO NOT OVER TIGHTEN.

IMPORTANT: Before replacing the blower motor assembly, check the installation for any application fault that might have caused the motor or control module to fail. Water damage could show as corrosion on the inside or outside of the casting. If so, run a Moisture Check.

10. Install the blower motor assembly back into the furnace. Follow the manufacturer's suggested procedures.
11. Plug the **control connector** into the motor. The connector is keyed. Be sure the connector is properly seated and latched.
12. Plug the **control connector** into the motor. The connector is keyed. Be sure the connector is properly seated and latched. OBSERVE THE PROPER ORIENTATION. DO NOT FORCE THE CONNECTOR. It plugs in very easily when properly oriented.

CAUTION

Reversing the 5-pin connector on the ECM motor causes immediate failure of the control module.

13. Final installation check. Be sure the motor is installed as follows.
 - a. Set the motor into the blower housing as originally provided from the manufacturer.
 - b. Do not allow the motor mount to cover the motor vent openings.
 - c. Do not attach the motor mount to the motor electronics compartment.
 - d. The motor connectors should be straight down.
 - e. Have appropriate drip loops formed in the harnesses.
14. Restore 230 volt power to the system. Verify that the new motor control module works properly.

13.9 BLOWER WHEEL REPLACEMENT

With the blower assembly removed and the motor assembly removed (see above instructions), remove the two screws holding the blower wrap (cutoff) to the blower sides.

IMPORTANT: It is not necessary to remove heating element(s), if provided, to remove the blower wheel.

- With wrap (cutoff) screws removed, cut off end of blower wrap will spring up. Lifting wrap blower wheel is removed through the discharge opening in the blower housing.
- To replace, make sure wheel is oriented properly with hub to the opposite side from the motor. Lift blower wrap and insert blower wheel through discharge opening in the blower housing.
- Hold blower wrap down into position and replace two screws holding blower wrap to blower sides.
- See motor replacement and blower assembly instructions for remaining assembly procedure.

14.0 REPLACEMENT PARTS

Any replacement part used to replace parts originally supplied on equipment must be the same as or an approved alternate to the original part supplied. The manufacturer will not be responsible for replacement parts not designed to physically fit or operate within the design parameters the original parts were selected for.

These parts include but are not limited to: Circuit breakers, heater controls, heater limit controls, heater elements, motor, motor capacitor, blower relay, control transformer, blower wheel, filter, indoor coil and sheet metal parts.

When ordering replacement parts, it is necessary to order by part number and include with the order the complete model number and serial number from the unit data plate. (See parts list for unit component part numbers).

15.0 ACCESSORIES - KITS - PARTS

- **Combustible Floor Base RXHB-17, RXHB-21, RXHB-24 (for standard units)** for downflow applications, see section of this manual covering combustible floor base.

Model Cabinet Size	Combustible Floor Base Model Number
17	RXHB-17
21	RXHB-21
24	RXHB-24

- External Filter Base RXHF- (See Figure 42)

Model Cabinet Size	Filter Size	Part Number	A	B
17	16 x 20 [406 x 508]	RXHF-17	15.70	17.50
21	20 x 20 [508 x 508]	RXHF-21	19.20	21.00
24	25 x 20 [635 x 508]	RXHF-24	22.70	25.50

FIGURE 42
EXTERNAL FILTER BASE: RXHF-

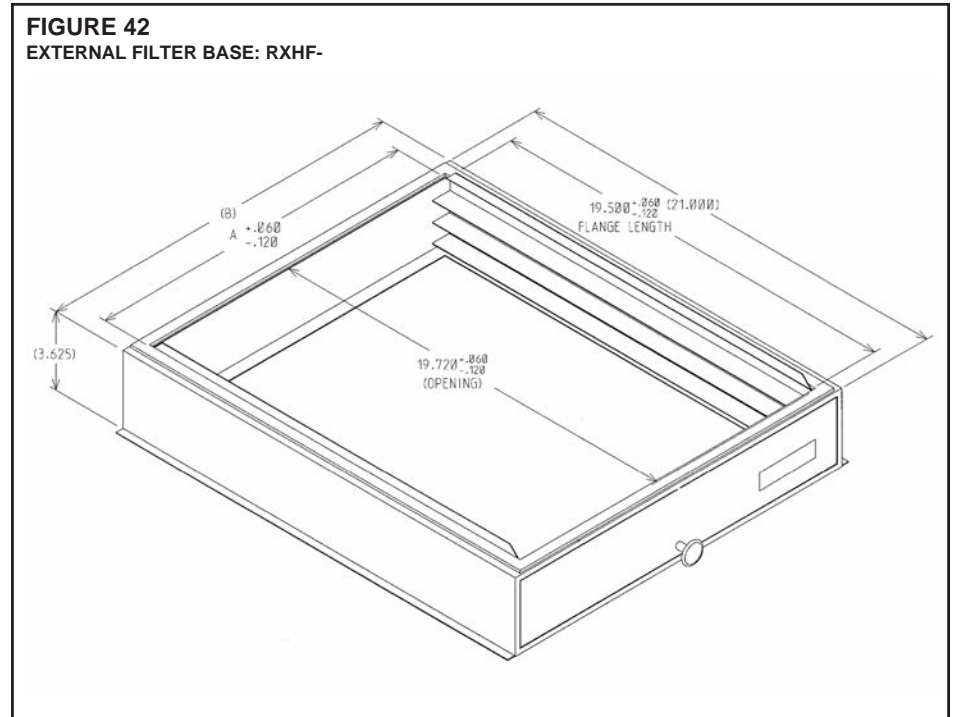

- **External Filter Rack: RXHF-B (See Figure 43)**

Model Cabinet Size	Filter Size	Part Number	A	B
17	16 x 20	RXHF-B17	16.90	20.77
21	20 x 20	RXHF-B21	20.40	20.77
24	25 x 20	RXHF-B24	25.00	21.04

FIGURE 43
EXTERNAL FILTER RACK: RXHF- B17, B21, B24

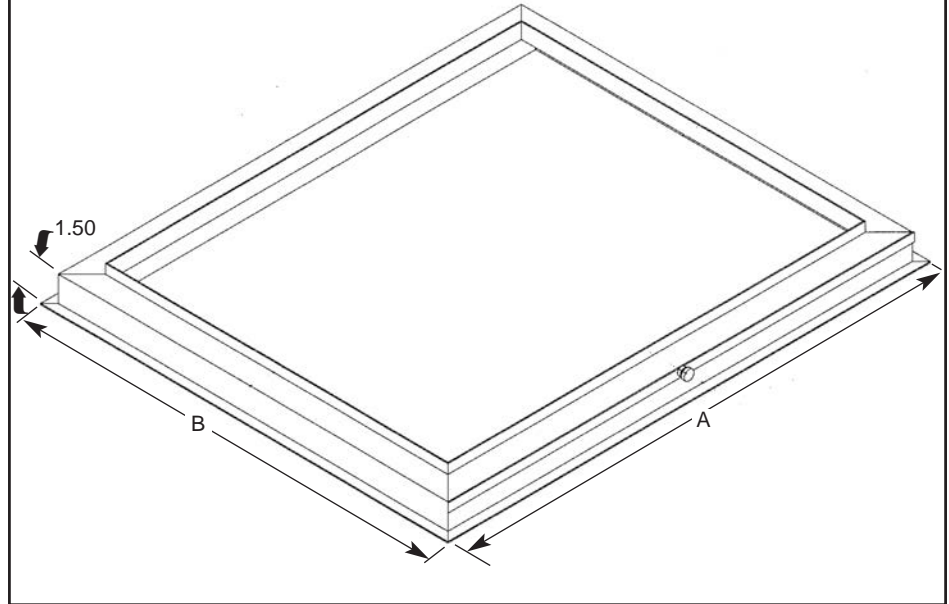

- **Horizontal Adapter Kit RXHH-**

This horizontal adapter kit is used to convert Upflow/Downflow only models to horizontal flow. See the following table to order proper horizontal adapter kit.

Coil Model	Horizontal Adapter Kit Model Number (Single Qty.)	Horizontal Adapter Kit Model Number (10-pak Qty.)
2414	RXHH-A01	RXHH-A01x10
2417	RXHH-A02	RXHH-A02x10
3617/3621	RXHH-A03	RXHH-A03x10
3821/4821/4824	RXHH-A04	RXHH-A04x10
6024	RXHH-A05	RXHH-A05x10

- **Auxiliary Horizontal Unit Overflow Pan Accessory RXBM-**

Nominal Cooling Capacity Ton	Auxiliary Horizontal Overflow Pan Accessory Model Number
1 ¹ / ₂ - 3	RXBM-AC48
3 ¹ / ₂ - 5	RXBM-AC61

FIGURE 44
COMFORT CONTROL² SYSTEM™ AIR HANDLER WIRING DIAGRAM (-H2V)

SCHEMATIC DIAGRAM

4 PIN CONNECTOR	PIN NO.	WIRE COLOR
	1	RD
	2	YL/PK
	3	OR/WH
	4	BR

WIRING DIAGRAM

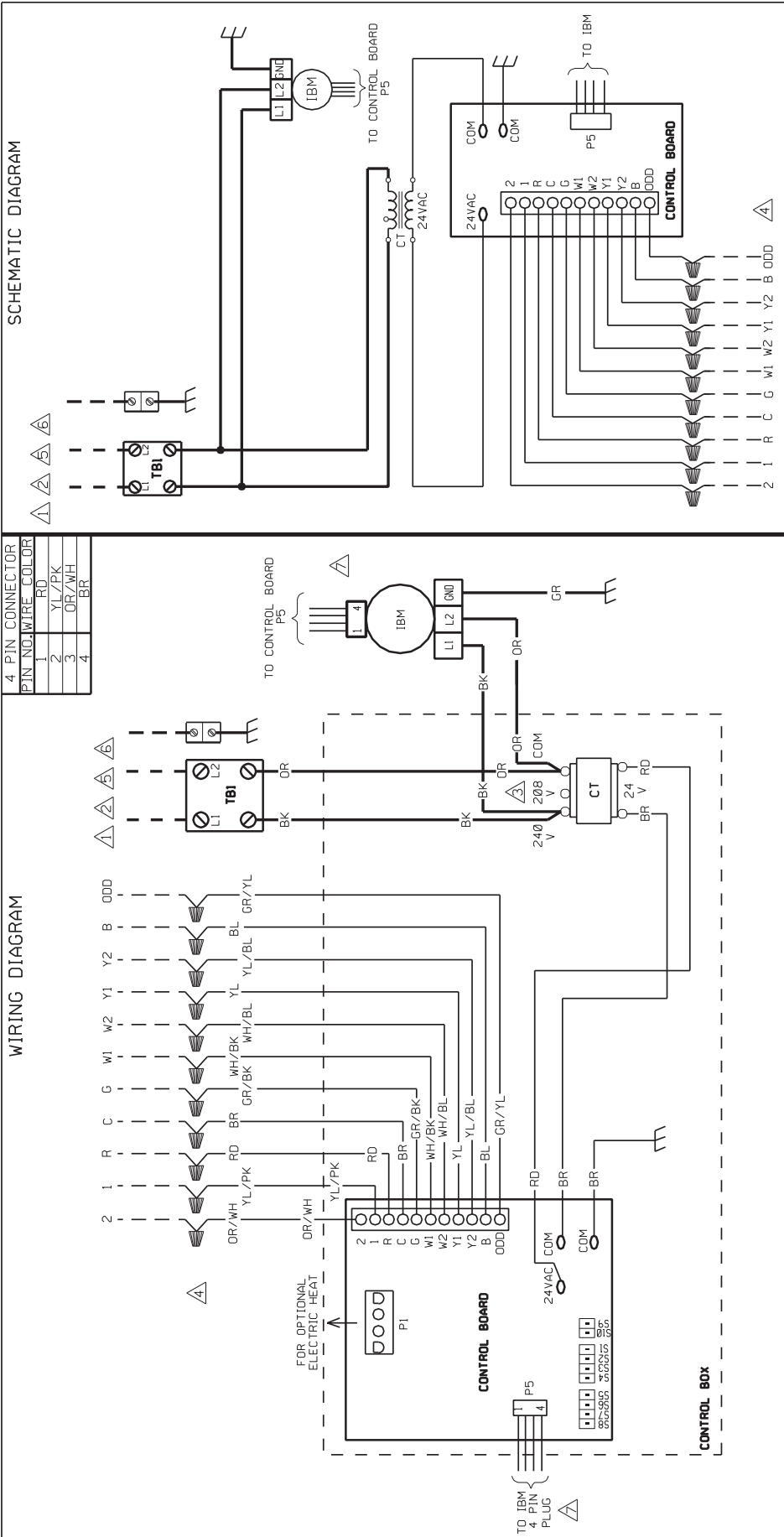

WIRE COLOR CODE	
BK	BLACK
BR	BROWN
BL	BLUE
GR	GREEN
CY	GRAY
OR	ORANGE
PR	PURPLE
RD	RED
WH	WHITE
YL	YELLOW

ELECTRICAL WIRING DIAGRAM	
ELECTRIC AIR HANDLER COMMUNICATING ECM MOTOR	
DR. BY	MGR
APP. BY	MGR
DATE	9-14-07
DWG. NO.	90-102638-01
REV	00

WIRING INFORMATION

- LINE VOLTAGE
- FACTORY STANDARD
- FACTORY OPTION
- FIELD INSTALLED
- LOW VOLTAGE
- FACTORY STANDARD
- FIELD INSTALLED
- REPLACEMENT WIRE
- MUST BE THE SAME SIZE AND TYPE OF INSULATION AS ORIGINAL (105 C° MIN.)

NOTES:

- CONNECT SUPPLY WIRING FOR VOLTAGE, PHASE AND HERTZ SHOWN ON RATING PLATE.
- SUPPLY WIRE MUST BE RATED AT 75° C MIN. SEE INSTRUCTIONS FOR SIZE.
- CT FACTORY WIRING FOR 240 VOLTS. MOVE WIRES FROM 240V TO 208V FOR 208V OPERATION.
- CONTROL WIRING TO THERMOSTAT.
- FOR USE WITH COPPER CONDUCTORS ONLY.
- WHEN HEATER KIT IS INSTALLED, POWER IS APPLIED TO HEATER KIT DISCONNECT OR TERMINAL BLOCK. WIRES ARE PROVIDED IN HEATER KIT TO CONNECT TO TBI. WITHOUT ELECTRIC HEAT, FIELD POWER WIRES ARE ATTACHED TO TBI.
- SEE CHART FOR WIRE COLORS.

COMPONENT CODE	
CT	CONTROL TRANSFORMER
GND	GROUND
IBM	INDOOR BLOWER MOTOR
TB	TERMINAL BLOCK (HI VOLT)
▲	WIRE NUT

