

PRINTING INSTRUCTIONS: MAKE EXACTLY 6.00 IN X 7.50 IN. WHITE BACKGROUND WITH BLACK PRINTING.

MATERIAL:ADS-4574-02, PRESSURE SENSITIVE, ADHESIVE BACKED MATERIAL.

REVISIONS

01	UPDATED "PL1" AND "COM2" ID'S IN CONTROL BOARD.	MAB	107527 9/6/2022
02	REVISED SPEED TAP TABLE.	MAB	114650 11/22/2023

NO REVISION TO DESIGN, MATERIAL, TOOLING, OR PROCESS IS ACCEPTABLE WITHOUT PRIOR APPROVAL FROM RHEEM THROUGH AN AUTHORIZED CHANGE NOTICE. A REVISED ENGINEERING SPECIFICATION AND A RESAMPLING OF PARTS. THE SUPPLIER IS RESPONSIBLE FOR NOTIFYING RHEEM R & D AND PURCHASING DEPARTMENTS IN WRITING OF ANY CHANGES AFFECTING PRODUCT QUALITY, PERFORMANCE, RELIABILITY, PACKAGING, DELIVERY OR WORKMANSHIP. ANY DOCUMENTS REFERRED TO ON THIS DRAWING ARE INCLUDED IN THE SPECIFICATIONS FOR THIS COMPONENT.

NOTE: THE DOTTED BOX NEAR THE DRAWING NUMBER REPRESENTS A .25 X .25 2D DATA MATRIX. SEE ADS-104669-01 FOR DATA MATRIX SPECS.

WIRING DIAGRAM

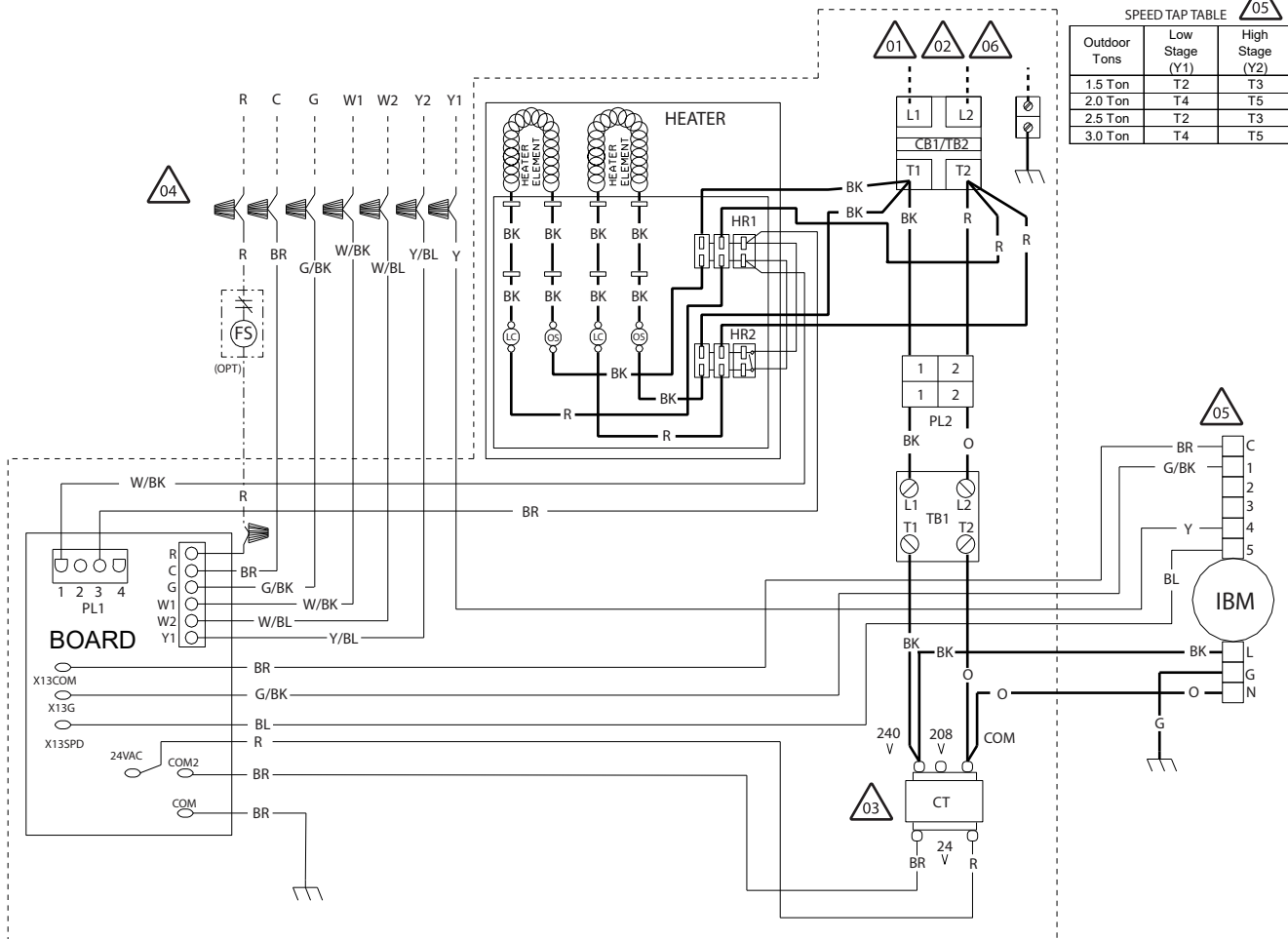

SCHEMATIC DIAGRAM

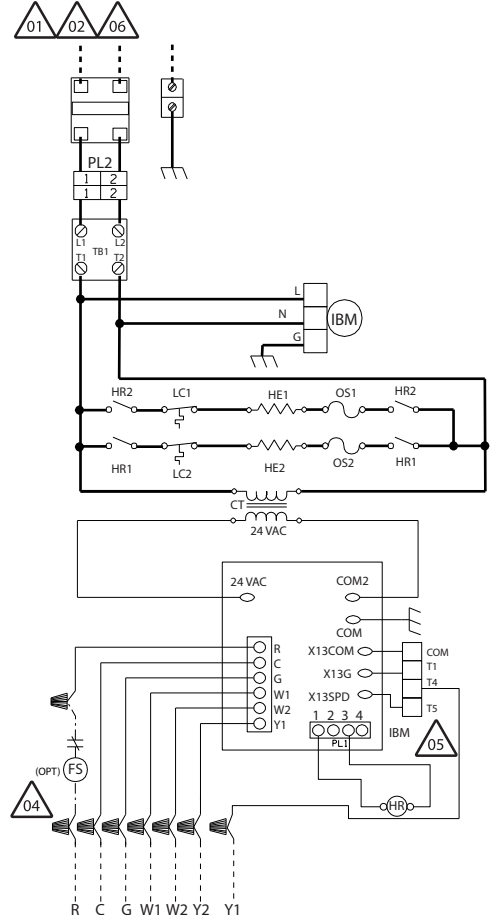

WIRING INFORMATION

LINE VOLTAGE
 -FACTORY STANDARD _____
 -FACTORY OPTION - - - - -
 -FIELD INSTALLED - - - - -

LOW VOLTAGE
 -FACTORY STANDARD _____
 -FACTORY OPTION - - - - -
 -FIELD INSTALLED - - - - -

REPLACEMENT WIRE
 -MUST BE THE SAME SIZE AND TYPE OF INSULATION AS ORIGINAL (105C. MIN.)
 WARNING
 -CABINET MUST BE PERMANENTLY GROUNDED AND CONFORM TO I.E.C., N.E.C., C.E.C., NATIONAL WIRING REGULATIONS, AND LOCAL CODE AS APPLICABLE.

- NOTES**
- CONNECT SUPPLY WIRING FOR VOLTAGE, PHASE AND HERTZ SHOWN ON RATING PLATE.
 - SUPPLY WIRE MUST BE RATED AT 75° C MIN. SEE INSTRUCTIONS FOR SIZE.
 - CT FACTORY WIRED FOR 240 VOLTS. MOVE WIRES FROM 240V TO 208V FOR 208V OPERATION.
 - CONTROL WIRING TO THERMOSTAT.
 - BLOWER SPEED SELECT (BL AND YL WIRES) ARE FACTORY WIRED TO HIGH SPEED TAPS 4 AND 5 RESPECTIVELY. SEE TABLE FOR OTHER TONNAGE CONFIGURATIONS.
 - FOR USE WITH COPPER CONDUCTORS ONLY.
 - USE PL1 FOR OPTIONAL ELECTRIC HEAT.

- COMPONENT CODES**
- BOARD CONTROL BOARD
 CB/TB CIRCUIT BREAKER OR TERMINAL BLOCK
 CT CONTROL TRANSFORMER
 FL FUSIBLE LINK
 FS FLOAT SWITCH
 GND GROUND
 HE HEATER ELEMENT
 HR HEATER RELAY
 IBM INDOOR BLOWER MOTOR
 LC LIMIT CONTROL
 OPT OPTIONAL
 OS "ONE SHOT" - SINGLE OPERATION
 TEMP CONTROL
 PL POLARIZED PLUG
 RC RUN CAPACITOR
 TDR TIME DELAY RELAY
 WIRE NUT

WIRE COLOR CODE

BK.....BLACK G.....GREEN PR.....PURPLE
 BR.....BROWN GY.....GRAY R.....RED
 BL.....BLUE O.....ORANGE W.....WHITE
 Y.....YELLOW

ELECTRICAL WIRING DIAGRAM

**ELECTRICAL AIR HANDLER
 208/240V CONSTANT TORQUE MOTOR
 8-10 KW ELECTRIC HEAT**

APPROVED:	CHECKED:	ORIGINAL RELEASE NO.:
MODELED BY: MAB	DATE: 11/9/2021	103230
PART NO.:	90-101897-20	REV: 02